

## UNIT III

### Repair materials

#### Essential parameters for repair materials- Polymer concrete- Expansive cement- Epoxy Resin-Sulphur Infiltrated Concrete-Fibre reinforced polymer - Corrosion control materials

##### Essential parameters for repair materials

- **Low shrinkage properties**

Cementitious material in its original form, if used for repair to concrete/mortar, is likely to get either delaminated due to de-bonding or develop shrinkage cracks on its surface due to shrinkage strains and stresses. It is, therefore, essential that the low shrinkage property of repair material shall be looked for while selecting a material for concrete repair.

- **Requisite setting/hardening properties**

It is desirable that the repaired structure shall be put to use at the earliest possible to reduce the down time of plant, machinery, building or road. It is, therefore, essential that repaired patch shall harden in the minimum possible time

- **Workability**

The property desired by the field workers is good workability. Hence optimum workability is to be achieved without sacrificing the other desirable properties by use of suitable additives/admixtures.

- **Good bond strength with existing substrate**

The bond strength of repair patch with the substrate is essential to have a successful repair system.

- **Compatible coefficient of thermal expansion**

The difference in volume change because of temperature variation can cause failure either at the bond line or within the section of lower strength material. Therefore, in the areas exposed to temperature variations, the patches of repair should have same coefficient of thermal expansion to ensure that no undue stresses are transferred to bonding interface or the substrate.

- **Compatible mechanical properties**

The hardened material shall have compatible mechanical properties or rather slightly better strength than that of base material. This property is desirable to ensure uniform flow of stresses and strains in loaded structures.

- **Relative movement, if expected**

Particularly in case of sealing of such cracks where movement is expected or at expansion joints, the repair material selected shall be resilient and elastic to be able to absorb the anticipated relative movements of the structure without any signs of distress or crack.

- **Minimal or no curing requirement**

It is desirable that the repair material shall not have any curing requirement after the repair has been applied or even if it is required, it should be minimal to ensure that the repair patch hardens and attains the desired strength without much post-repair-care.

- **Alkaline character**

In case of RCC, it is important to maintain the alkalinity of concrete around reinforcement with its pH above 11.5 from corrosion protection point of view. In this context, it is necessary for the repair material to have chemical characteristics such that it does not adversely affect the alkalinity of the base concrete at a later date.

- **Low air and water permeability**

Permeable material allows easy permeation of environmental chemicals including carbon dioxide, water, oxygen, industrial gases/vapours etc. It is essential that repair materials should have a very low air/water permeability to provide protection to the reinforced concrete against ingress of harmful environmental chemicals.

- **Aesthetics to match with surroundings**

It is desirable that colour and texture of the repair material should match with the structure and give aesthetically pleasant appearance.

- **Cost**

Economics is important while considering various options for repair materials but cheaper repair material should not be selected at the cost of performance characteristics.

- Durable, non degradable or non-biodegradable due to various forms of energy, life,
- The repair material selected should be durable under its exposure conditions during the service life against chemical attack, resistant to any for UV rays, heat etc

- **Non-hazardous/non-polluting**

The repair materials should not be hazardous to field workers. These should also be environment friendly.

### **Polymer concrete**

Polymer concrete is a composite material in which the aggregate is bound together in a matrix with a polymer binder. Polymers are long molecules, built by combination of single units called monomers. Polymers are essentially hydrocarbons. The process of conversion of monomers into polymer is called polymerisation.

#### **Types of Polymer concrete**

Three types of polymer concrete materials are being developed presently. They are:

- (a) Polymer Impregnated Concrete (PIC).
- (b) Polymer Cement Concrete (PCC).
- (c) Polymer Concrete (PC).

##### *a) Polymer Impregnated Concrete (PIC)*

In the polymer impregnated concrete, low viscosity liquid monomers or prepolymers are partially or completely impregnated (infiltrated) into the pore systems of hardened cement composites and are then polymerized by steam or infrared heater and radiation. The partial or

surface impregnation improves durability and chemical resistance while the total impregnation improves the structural properties.

Mainly the following *types* of monomer are used Methylmethacrylate (MMA), Styrene, Acrylonitrile, Epoxies

*b) Polymer Cement Concrete (PCC)*

- Polymer cement concrete is made by mixing cement, aggregates, water and polymers. The polymeric materials is in form of lattices added to modify cement concretes.
- The quantity of polymer in PCC is in the range of 1 to 4% by mass of composite and hence less expensive.
- The ductility is improved and microcracks are avoided.
- Improved tensile strength, modulus of elasticity, durability and excellent bond of latex concrete with existing concrete.

Two types of polymer are employed in lattices

*1) Elastometric polymers*

They are characterized by their rubber like elongation and low modulus of elasticity  
Examples: Natural rubber latex, Neoprene, Styrene-butadiene rubber latex

*2) Glassy polymers*

They are characterized by high strength, high modulus of elasticity and relative brittle type of failure. Example: Polyester-styrene, Epoxy-styrene, Furans, Vinylidene Chloride.

**c) Polymer Concrete (PC)**

- Polymer concrete is an aggregate bound with a polymer binder instead of Portland cement as in conventional concrete.
- The main technique in producing PC is to minimize void volume in the aggregate mass so as to reduce the quantity of polymer needed for binding the aggregates.

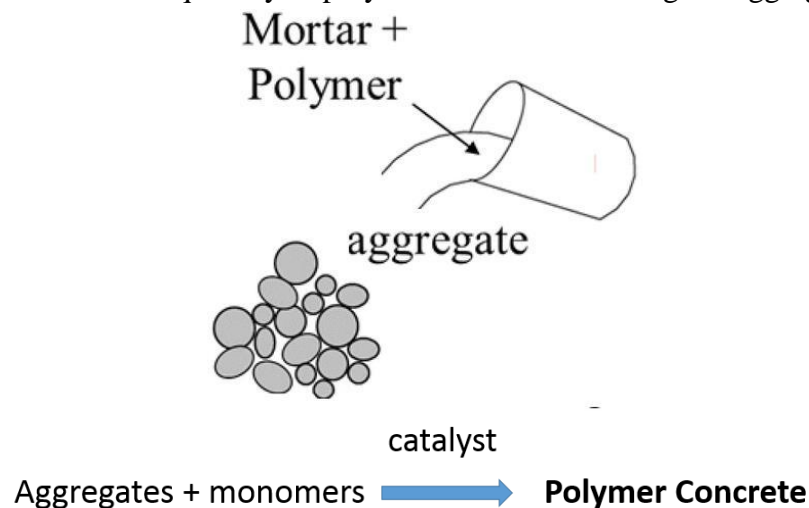

- This is achieved by properly grading and mixing the aggregates to attain the maximum density and minimum void volume.
- The graded aggregates are prepacked and vibrated in a mould.
- Monomer is then diffused up through the aggregates and polymerisation is initiated by following methods.
- The polymers used are Methyl-methacrylate, Styrene, Furfuryl acetone and Polyester

styrene

1. *Thermal catalytic reaction*- decomposing catalyst such as benzoyl peroxide, benzenesulphonic acid at 90°C
2. *Catalyst promoter reactions*- Promoters such as naphthanate and ferric chloride are used
3. *Radiation*- Gamma radiation

### **Expansive cement**

- Expansive cement is special type of cement when mixed with water, which forms a paste that tends to increase in volume to a significantly greater degree than Portland cement paste after setting.
- The expansion of the cement mortar or concrete is compensated for the shrinkage losses.

#### **Manufacture of expansive cement**

- The process of manufacture if this type of cement is same as that of Portland cement, but the raw materials used for formation of clinkers are different.
- Firstly limestone and clay are heated together to a temperature of around 1430 degrees C and clinkers are formed and in the next batch limestone, calcium sulphate and bauxite together at a temperature of about 1260 degrees C, where sulfoaluminate clinkers are formed.
- These two clinkers are grounded together to form expansive cement. when this cement is exposed or mixed with water, sulfoaluminate expands in volume.

#### **Type of expansive cement**

##### **1. K Type expansive cement**

The raw material in this type of cement contains, portland cement, anhydrous tetracalcium trialuminate sulfate ( $C_4A_3S$ ), calcium sulfate ( $CaSO_4$ ), and lime ( $CaO$ ), which are grounded and expansive cement is formed.

##### **2. M Type expansive cement**

The Portland cement clinkers are grounded with calcium sulfate.

##### **3. S Type expansive cement**

In this type of expansive cement, a portland cement containing a high computed tricalcium aluminate ( $C_3A$ ) content and an amount of calcium sulfate above the usual amount found in portland cement.

### Uses of Expansive Cement

- This cement is used in large, continuous floor slabs without joints
- It work well to fill holes in foundations and to create self-stressed concrete that is stronger than conventional portland cement concrete.
- Pre-stressed concrete components for bridges and buildings are made using this material.
- Used for construction of water retaining structures and also for repairing the damaged concrete surfaces.
- Used in grouting of anchor bolts.

### Epoxy resin

Epoxy resin is a type of polymer matrix used in composite materials, adhesives, coatings, and various other applications. It is a thermosetting polymer, meaning it undergoes a chemical reaction to form a solid, cross-linked structure when cured. Epoxy resins are well-known for their exceptional bonding strength, excellent mechanical properties, and resistance to chemicals and moisture.

The most important raw material used in epoxy resin production is epichlorohydrin, which is used as a precursor for nearly every commercially available epoxy resin. The basic epoxy resin used in the building industry is “**DiGlycidyl Ether of Bisphenol-A**” (DGEBA)

### **EPOXY RESIN SYSTEMS**

Epoxy resin systems are made up of an epoxy resin and a curing agent (also called a hardener or catalyst). Many epoxy products contain additives such as organic solvents, fillers such as fiberglass or sand, and pigments.

**Coal Tar Epoxy System:** Coal Tar epoxy resin combinations with polyamine hardener have been widely used as water resistant protective coatings. Coal Tar plays an important part in the improvement of corrosion resistance of epoxy resin system.

**Rubber Modified Epoxy System:** This system is used to improve the drawback of brittleness and low elongation of unmodified epoxy resin based on bisphenol-A and epichlorohydrin with hardeners such as polyamines and anhydrides. The system possessing both small and large particles provides maximum toughness.

**Epoxy Phenolic IPN Systems:** Central Building Research Institute (CBRI), Roorkee has developed an Epoxy-Phenolic Interpenetrating Polymer Network (IPN) system for protection of rebar. IPNs are relatively novel types of polymer alloys.

**Composite Fibre System:** The system comprises of a fiber reinforcement layer that is wrapped to the exterior surface of the structural element to be retrofitted. The fiber composite reinforcement layer consists of at least one fabric layer that is located within a resin matrix. The composite reinforcement layer provides a quick, simple and effective means for increasing the resistance of the structural element to failure during the application of loads.

**Epoxy Mortar and Concrete:** Epoxy resins are used with aggregate (silica sand) to produce epoxy mortar or epoxy concrete, which is used for structural repairs of concrete, RCC besides its use in new construction in industrial flooring, foundation grouting, roads etc.

**Hardener/curing agent**

Out of a vast number of compounds, most commonly used curing agents are aliphatic and aromatic amines and polyamides and their adducts, which form room temperature curing compositions relevant to construction applications.

**Key characteristics of epoxy resin:**

**Versatility:** Epoxy resins can be formulated with various curing agents to achieve different properties and cure times. This versatility allows them to be tailored to specific applications.

**High Strength:** Epoxy resins, when cured, exhibit high tensile, compressive, and flexural strengths, making them ideal for load-bearing applications.

**Adhesive Properties:** Epoxy resins are widely used as structural adhesives due to their strong bonding capabilities for a wide range of materials, including metals, plastics, and composites.

**Chemical Resistance:** Epoxy resins offer excellent resistance to many chemicals, including acids, bases, and solvents, making them suitable for use in harsh environments.

**Low Shrinkage:** During curing, epoxy resins typically experience minimal shrinkage, allowing for precise molding and dimensional stability.

**Electrical Insulation:** Epoxy resins are excellent electrical insulators, making them useful in electrical and electronic applications.

**Transparent and UV-resistant:** Some epoxy formulations can be optically clear and resistant to UV degradation, making them suitable for applications where transparency and UV stability are required.

**Applications of epoxy resin:**

**Composite Materials:** Epoxy resin is commonly used as a matrix material in fiber-reinforced composites, such as fiberglass and carbon fiber composites, to enhance mechanical properties.

**Adhesives:** Epoxy-based adhesives are widely used in construction, aerospace, automotive, and marine industries for bonding various materials.

**Coatings and Sealants:** Epoxy coatings provide protective and decorative finishes on floors, walls, and industrial equipment. Epoxy sealants are used for waterproofing and sealing purposes.

## Sulphur infiltrated concrete

- Sulphur infiltrated concrete was developed as an economical alternative to polymer impregnated concrete (PIC) to be used for higher strength and durable precast elements.
- Sulphur is considerably cheaper than polymers and the technique of impregnation is more simple.

### Criteria

- The concrete to be infiltrated should be produced using normal aggregates with aggregate/cement ratios between 3:1 to 5:1.
- The water/cement ratio should be high between 0.7 and 0.8.
- The size of coarse aggregate should be 10 mm and below.
- It should be well graded.
- The fine aggregate should be of good quality.
- Sulphur also should be of high purity of 99.9%

### Manufacture of Sulphur infiltrated concrete

#### **Method-1**

- After moist curing of elements for 24 hours at about 23°C, they are dried at 121°C to 125°C for another 24 hours.
- After drying, the specimens are immersed in molten sulphur at 121°C under vacuum for 3 hours.
- The specimens are removed from container, wiped clean of sulphur and allowed to cool to room temperature for one hour and weighed to determine the weight of sulphur infiltrated in concrete.

#### **Method -2**

- In this case, the dried concrete specimen is placed in an air tight container and subjected to vacuum pressure of 2 mm of mercury for 2 hours.
- After releasing the vacuum, the specimens are soaked in the molten sulphur at atmospheric pressure for another half an hour.
- The specimen is taken out, wiped clean, cooled to room temperature for about an hour.
- The specimen is weighed and the weight of sulphur impregnated in concrete is determined.

### Mechanical properties

- Water/cement ratio 0.7, the increase in compressive strength of cubes prepared by procedure B is found about 7 times higher. With the use of 0.8 water/cement ratio, cubes prepared by procedure B gave about 10 times higher strength.
- Similarly specimens prepared by procedure B gave more than 4 times increase in splitting tensile strength.
- The elastic properties of sulphur infiltrated concrete improved by 100%.
- Sulphur infiltrated concrete showed a very high resistance to freezing and thawing.

### Durability of Sulphur Infiltrated Concrete (SIC):

- The performance of the sulphur infiltrated concrete generally has been found satisfactory against freezing and thawing, sea water attack, wetting and drying conditions.
- It is more durable than conventional concrete in high concentrations of  $H_2SO_4$  and HCl.
- The strength properties are not significantly affected when exposed to short term temperatures upto  $100^\circ C$ . At these temperatures it shows certain amount of ductility before failure.
- The increase in abrasion resistance depends on the sulphur loading in the concrete. The sulphur filling of the pores of the concrete provides an un-interrupted path for heat flow resulting in increased thermal conductivity over that of normal dry concrete.
- This concrete provides a corrosive protection cover to the embedded steel.
- When left in stagnant water for a long time, slight leaching of sulphur has been observed and the concrete showed undesirable expansion followed by cracks.

### Uses of Sulphur Infiltrated Concrete:

- For making precast roof elements, fencing posts, pig pipes
- For making Railway sleeper
- In industries where high corrosion resistance is required.
- Precast concrete is cheaper than commercial concrete.



## Fibre Reinforced Polymer

Fiber Reinforced Polymer (FRP), also known as Fiber Reinforced Plastic, is a composite material composed of a polymer matrix reinforced with fibers. Composite materials are made by dispersing particles of one or more materials in another material, which forms a continuous network around them.

The primary function of fibre reinforcement is to carry the load along the length of the fiber and to provide strength and stiffness in one direction. It replaces metallic materials in many structural applications where load-carrying capacity is important.

These materials have a high ratio of strength to density, exceptional corrosion resistance and convenient electrical, magnetic and thermal properties. The use of FRP in engineering applications enables engineers to obtain significant achievements in the functionality, safety and economy of construction because of their mechanical properties.

### Components of Composite Materials

#### 1. Fibres

The choice of fibre frequently controls the properties of composite materials. Carbon, Glass, and Aramid are three major types of fibres which are used in construction. The composite is often named by the reinforcing fibre, for instance, CFRP for Carbon Fibre Reinforced Polymer. The most important properties that differ between the fibre types are stiffness and tensile strain.

#### 2. Matrices

The matrix should transfer forces between the fibres and protect the fibres from detrimental effects. Thermosetting resins (thermosets) are almost exclusively used. Vinylester and epoxy are the most common matrices.

Epoxy is mostly favoured above vinylester but is also more costly. Epoxies have good strength, bond, creep properties and chemical resistance.

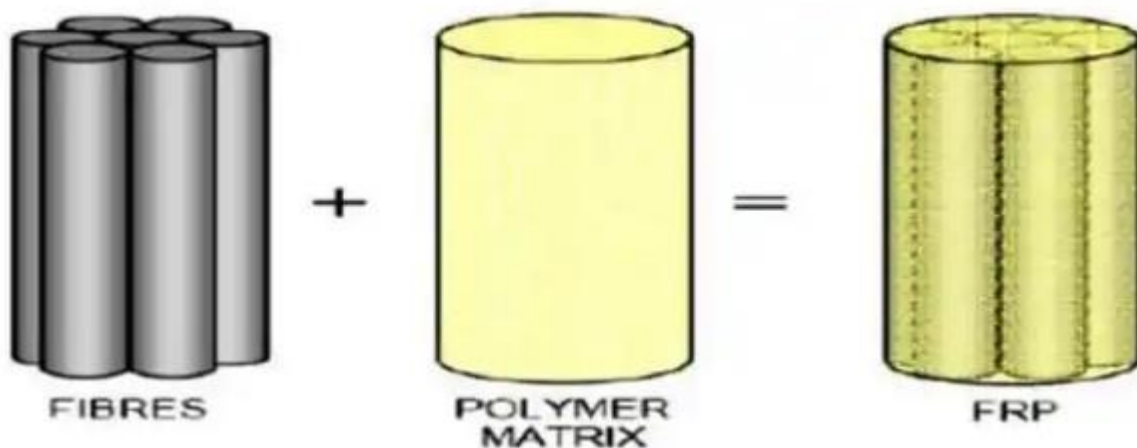

## Types of Fibre Reinforced Polymer (FRP)

### 1. Glass Fibre Reinforced Polymer (GFRP)

Glass fibres are considered as the predominant reinforcement for polymer matrix composites due to their high electrical insulating properties, low susceptibility to moisture and high mechanical properties. Glass is generally a good impact resistant fibre but weighs more than carbon or aramid. Glass fibres have excellent characteristics equal to or better than steel in certain forms.

### 2. Carbon Fibre Reinforced Polymer (CFRP)

Carbon fibres have a high modulus of elasticity, 200-800 GPa. The ultimate elongation is 0.3-2.5 % where the lower elongation corresponds to the higher stiffness and vice versa. Carbon fibres do not absorb water and are resistant to many chemical solutions. They withstand fatigue excellently and neither corrode nor show any creep or relaxation.

### 3. Aramid Fibre Reinforced Polymer (AFRP)

Aramid is the short form for aromatic polyamide. The modulus of elasticity of the fibres are 70-200 GPa with an ultimate elongation of 1.5-5% depending on the quality. They offer excellent impact resistance and are used in protective equipment and structures.

## Advantages of FRP

**High Strength-to-Weight Ratio:** FRP composites are stronger and lighter than traditional materials like steel and concrete.

**Corrosion Resistance:** FRP does not rust or corrode, making it ideal for applications in harsh environments.

**Design Flexibility:** FRP can be easily molded into complex shapes, allowing for tailored designs to meet specific requirements.

**Fatigue Resistance:** FRP exhibits excellent fatigue properties, making it suitable for structures subjected to repetitive loading.

**Electrical and Thermal Insulation:** FRP is non-conductive and provides thermal insulation, making it suitable for electrical and thermal applications.

## Disadvantage

Brittle and their mechanical properties may be affected by the rate of loading, temperature and environmental conditions.

## Applications of FRP

1. Carbon FRPs are used in prestressed concrete for applications where high resistance to corrosion and electromagnetic transparency of CFRP are important.
2. CFRP composites are employed for underwater piping and structural parts of offshore platform. Added to that, FRP declines the risk of fire.
3. Carbon fibre reinforced polymers are used to manufacture underwater pipes for great depth because it provides a significantly increased buoyancy (due to its low density) compared to steel.
4. The stairways and walkways are also made of composites for weight saving and corrosion resistance.
5. It is used in high-performance hybrid structures.

6. FRP bars are used as internal reinforcement for concrete structures.
7. FRP bars, sheets, and strips are used for strengthening of various structures constructed from concrete, masonry, timber, and even steel.
8. FRPs are employed for seismic retrofitting.
9. Fibre reinforced polymers are used in the construction of special structures requiring electrical neutrality.
10. The high energy absorption of aramid fibre reinforced polymer (AFRP) composites makes them suitable for strengthening engineering structures subjected to dynamic and impact loading.

## **Corrosion control materials**

### **1. Blended cements**

High cement content, Low water/cement ratio and blended cements have shown better corrosion resistance as compared to OPC.

### **2. Hot-dipped galvanizing reinforcement**

The hot dip galvanizing process applies a continuous metallic zinc coating to steel rebar by immersing the bars in a bath of molten zinc at about 450°C.

### **3. Corrosion Inhibitors**

- *Anodic inhibitors*- calcium nitrite to suppress the anodic corrosion reaction
- *Cathodic inhibitors*- sodium hydroxide to suppress the cathodic corrosion reaction,
- *Mixed inhibitors* (Bipolar)-Benzoate which suppress both anodic and cathodic reactions

### **4. Using Alternative Reinforcement**

#### **1. Stainless Steel bars**

- Stainless Steel bars is significantly higher corrosion resistance than carbon or mild steel because of the higher stability of their passive film.
- The film is rich in chromium and has a good bond with the parent metal

#### **2. Fibre-Reinforced Plastic (FRP) Rebars**

- High corrosion resistance, light weight and high tensile strength

### **5. Steel Coating**

Coatings act as a physical barrier to corrosion.

#### **a) Metallic Coatings**

- *Sacrificial coatings* are made up of less noble metals such as zinc and aluminium which provide protection to steel by sacrificing themselves compared to the underlying cathode, i.e. parent metal.
- *Non-sacrificial coatings* include Titanium and Stainless steel which provide barrier protection to steel, i.e. protect the steel by forming a passive layer on it.

## **b) Organic coatings**

- Organic coatings include fusion bonded epoxy coated rebar , polyvinyl chloride, poly-propylene, polyurethane.
- Most widely used, fusion bonded epoxy coated rebar have electrostatically applied epoxy powder on thoroughly cleaned and heated bar.

## **6. Concrete Coating**

- The main objective of surface treatment is to provide a barrier between concrete surface and environment.
1. *Organic coatings* are based on epoxy, polyurethane or chlorinated rubber polymer
  2. *Cementitious coatings* can be cement-based coatings, polymer-modified cementitious coatings
  3. *Hydrophobic impregnation materials* include silanes, siloxanes and silicate-based compounds

Prepared by

Dr K Thulasirajan MTech Ph.D

Associate Professor

AITS, Tirupati

## RRS-UNIT IV

### **Epoxy injection- Routing and sealing- Blanketing- External stressing- Stitching- Autogenous Healing - Grouting-Dry packing- Prepacked concrete-Cathodic protection- Shotcrete- Repairs in under water structures**

#### **Repair method**

##### **Objectives of repair method selection**

- restore and increase strength;
- restore and increase stiffness;
- improve functional performance;
- provide water tightness;
- improve appearance of the concrete surface;
- improve durability;
- prevent development of a corrosive environment at the reinforcement.

##### **Important factors to be considered for selection of repair methods**

- Type and extent of distress
- Location of distress
- Environmental exposure
- Availability of skill
- Availability of time and access for repairs.
- Appearance
- Cost

#### **Crack Repair Techniques**

- 1) Sealing with Epoxies
- 2) Routing and Sealing
- 3) Stitching
- 4) External Stressing
- 5) Blanketing
- 6) Grouting
- 7) Overlays
- 8) Autogeneous Healing

##### **1.Sealing with Epoxies**

Epoxy injection method is used for cracks as narrow as 0.05 mm. The technique generally consists of establishing entry and venting ports at close intervals along the cracks, sealing the crack on exposed surfaces, and injecting the epoxy under pressure.

Cracks in concrete can be sealed by injecting epoxy with pressure into the cracks. Steps involved in this method:

- 1) drill into the crack from the face of the concrete at several locations
- 2) flush out dirt by injecting water or some solvent
- 3) allow the surface to dry
- 4) surface-seal the cracks between the injection points

- 5) inject the epoxy into the drilled holes until it flows through the other holes

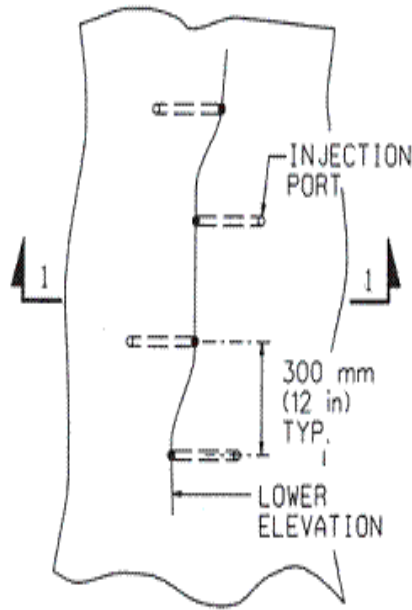

**NOTES**

1. REMOVE LOOSE MATERIAL FROM CRACK.
2. DRILL 15 MM (5/8 IN) DIA. INJECTION PORTS AT 45 DEG. ANGLE TO CRACK, ALTERNATING SIDES.
3. INSTALL MECHANICAL PACKER IN INJECTION PORT.
4. SEAL SURFACE OF CRACK WITH LOW-MODULUS GEL IF CRACK IS ACTIVELY LEAKING.
5. FLUSH CRACK WITH CLEAN WATER.
6. INJECT LIQUID URETHANE OR ACRYLATE ESTER RESIN INTO LOWEST MECHANICAL PACKER WITH HAND OPERATED HYDRAULIC PUMP UNTIL GROUT CAN BE SEEN AT THE NEXT INJECTION PORT UP.
7. REPEAT PROCESS UNTIL ENTIRE CRACK IS INJECTED.
8. REGROUTING MAY BE PERFORMED FOR UP TO A WEEK AFTER INITIAL GROUTING.

Epoxy injection is used in the repair of cracks in buildings, bridges, dams, and other types of concrete structures.

*Limitation*

- 1) Crack must be dormant or the cause of cracking is removed
- 2) Not applicable if the defects are actively leaking to the extent that they cannot be dried out, or where the cracks are numerous.
- 3) Epoxy injection requires a high degree of skill for satisfactory execution.
- 4) Not applicable if the cracks are large in number

**2. Routing and Sealing**

Routing and sealing is used to treat fine pattern cracks, larger and isolated cracks. This treatment reduces the ability of moisture to reach the reinforcing steel or pass through the concrete, causing surface stains or other problems. For floors, the sealant should be sufficiently rigid to support the anticipated traffic. Satisfactory sealants should be able to withstand cyclic deformations and should not be brittle.

*Materials*

The sealants used are epoxies, urethanes, silicones, polysulfides, asphaltic materials, or polymer mortars.

*Method*

- The procedure consists of preparing a groove at the surface ranging in depth, typically, from 6 to

25 mm.

- A concrete saw, hand tools or pneumatic tools may be used.
- The groove is then cleaned by air blasting, sandblasting, or waterblasting, and dried.
- A sealant is placed into the dry groove and allowed to cure.

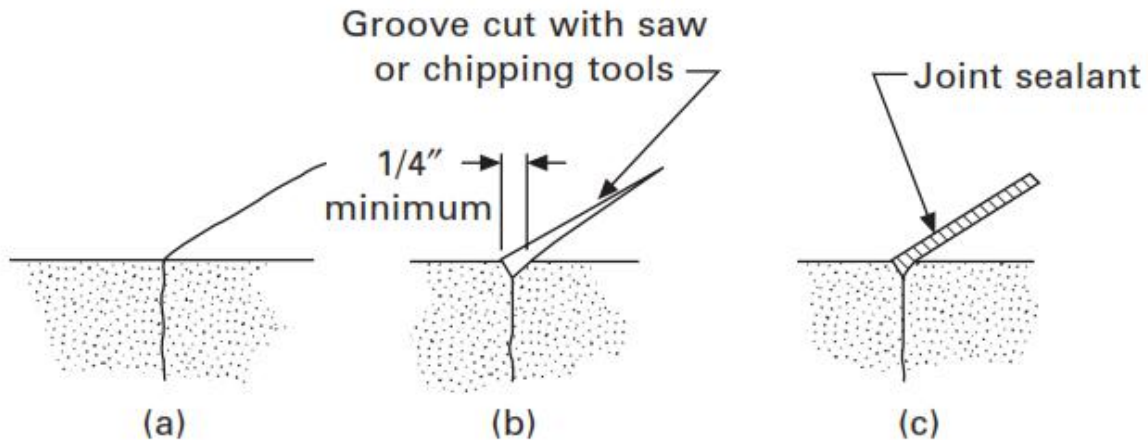

- A bond breaker may be provided at the bottom of the groove to allow the sealant to change shape, without a concentration of stress on the bottom
- The bond breaker may be a polyethylene strip or tape which will not bond to the sealant.

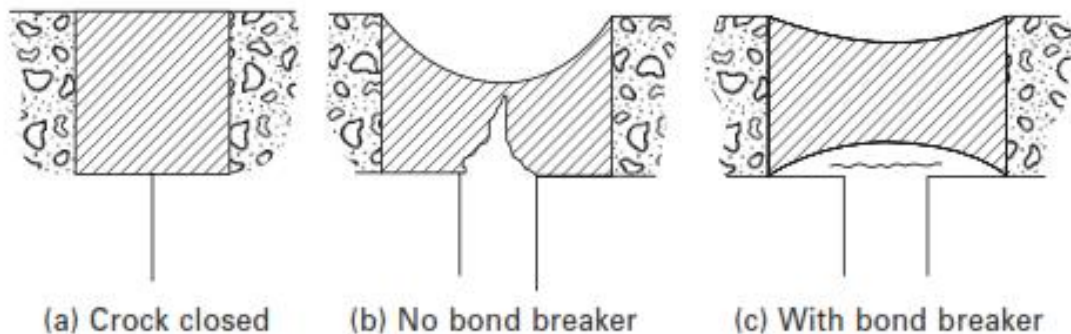

#### *Advantages*

- 1) Simplest and common method for sealing fine pattern cracks and large isolated cracks.
- 2) Inexpensive and practical technique.
- 3) Water-tightness of the joint is not required.
- 4) Useful when appearance is not important.

#### *Limitations*

- 1) The cracks must be dormant.
- 2) For leaking cracks the method must be applied on the pressure face so that the water-aggressive agents cannot penetrate the interior of the concrete.
- 3) Carelessness can cause side-effects such as swelling, chemical attack or corrosion of the

rebars

### Uses

A common and effective use is for waterproofing by sealing cracks on the concrete surface where water stands, or where hydrostatic pressure is applied.

### 3.Stitching

- Stitching involves drilling holes on both sides of the crack and grouting in U-shaped metal units with short legs (staples or stitching dogs) that span the crack.
- The tensile strength of a cracked concrete section can be restored by stitching in a manner similar to sewing a cloth, but using iron or steel dogs.
- Dogs of variable length are placed at varied locations and orientation so that the tension across the crack is distributed throughout rather than being concentrated on a single plane.
- The stitching procedure consists of drilling holes on both sides of the crack, cleaning the holes, and anchoring the legs of the staples in the holes.
- The holes drilled in the concrete to receive the dogs must be finally filled with non-shrink grout or an epoxy resin-based bonding system.

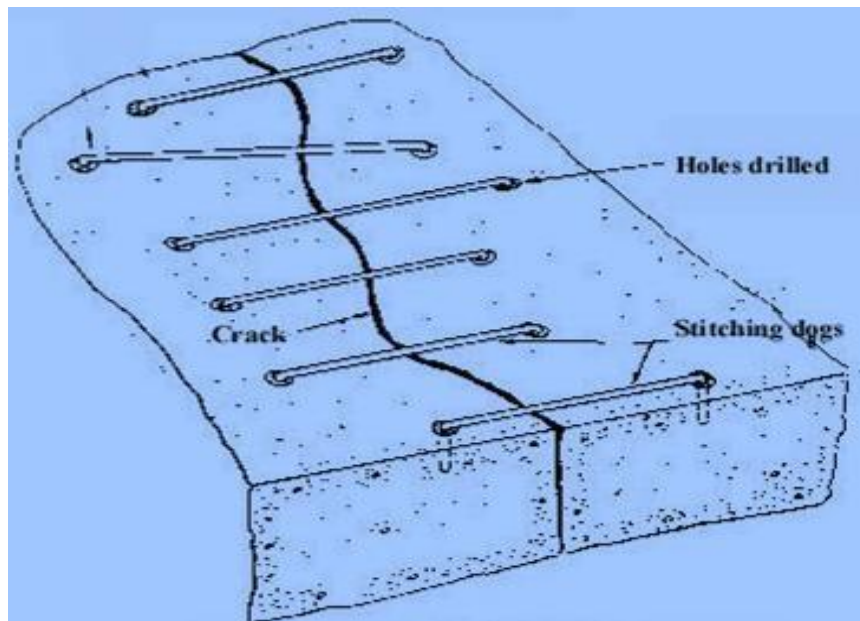

- Cautions in using this technique:
  - Over strengthening of the crack joint tends to stiffen the structure locally.
  - Stitching the crack will tend to migrate the crack elsewhere in the structure.
  - In places where water ingress is likely the crack must be sealed in addition to stitching.
  - At the ends of the cracks, where the stress concentration is more, the spacing between the stitching dogs must be reduced.



- The stress concentrations at each end of the crack can also be relieved by drilling suitable holes or marking the ends rounded.
- Whenever possible both sides of the cracks must be stitched to prevent bending of the dogs due to the movement of the structure.
- The dogs are thin and long and so cannot take much of compressive force. These must be stiffened and strengthened by encasing them in an overlay.

#### 4.External Stressing

External stressing is often the desirable solution when a major portion of a member must be strengthened or when the cracks that have formed must be closed. This technique uses pre stressing strands or tie rods to apply a compressive force. Adequate anchorage must be provided for the prestressing steel, and care is needed so that the problem will not merely migrate to another part of the structure.

- Involves counteracting the tensile stress that causes cracking by inducing a compression force.
- This compression force not only overcomes tension but also provides a residual compression.
- The compressive force is applied by using pressing wires or rods.
- The principle is similar to stitching except that the stitches are pre-tensioned

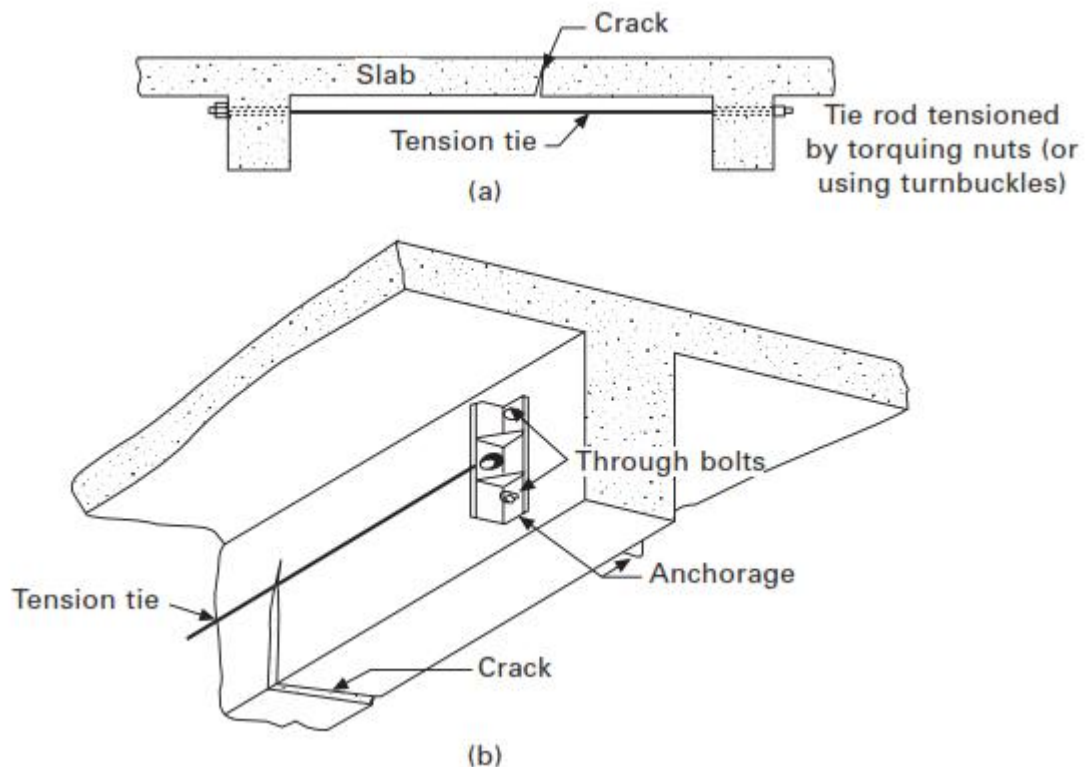

#### Advantages

- Ability to restress and destress
- Crack free members.
- Reduce deflection.

- High fatigue and impact resistance.

### Disadvantages

- Usually requiring a greater section depth.
- More exposed to environmental influences (fire, aggressive chemicals etc.).
- Handling of the tensioning devices may be more difficult.
- High cost.

### 5.Blanketing

Technique is similar to routing and sealing but is used on a large scale for sealing both active and dormant cracks.

- Preparing the chase is the first step
- Usually the chase is cut square or trapezoidal.
- The bottom should be chipped as smooth to facilitate breaking the bond between sealant and concrete
- The sides of the chase should be prepared to provide a good bond with the sealant material

Materials used: Rubberized Bitumen Sealant, Polymeric Sealant, Silicone Sealant, Polyurethane Sealant, Polysulphide Sealant, Polyurethane Polymer Sealant

The first consideration in the selection of sealant materials is the amount of movement anticipated and the extremes of temperature at which such movements will occur. Depending on the need different types of sealants are used.

- Elastic sealants
- Mastic sealants
- Mortar-plugged joints
- Crimped water bar

**a)Elastic sealants:** At a crack or a joint an elastic sealant is used. The sealant material is one which returns to its original shape when the externally induced stress is removed. When the crack width is small, a strip sealant is sufficient.

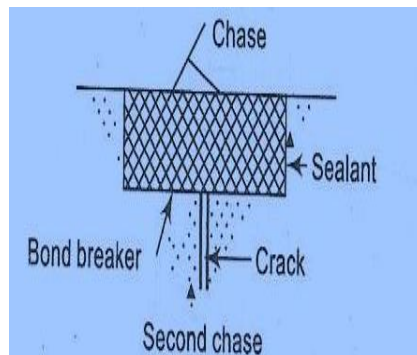

**b)Mastic-filled Joint:** The sealant is mastic rather than a compound with elastic properties. Its viscous nature makes it the best fit for thick areas of application. The sealant is bonded to the

bottom as well as to the sides of the chase. The bond breaker at the bottom is omitted.

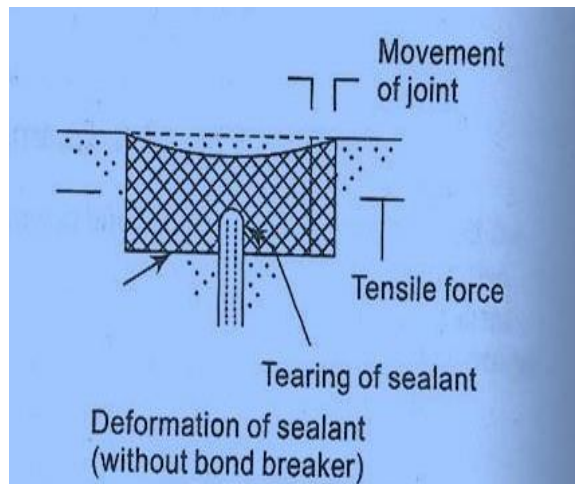

**c) Mortar-plugged joint:** The chase is cut in the form of a trapezoid and filled with mortar. Generally, internal stresses in the mortar due to external and internal pressures are created. The pressure relieving groove on the surface of the plugged mortar and cutting and closing the mouth tip of the crack with quick set mortar.

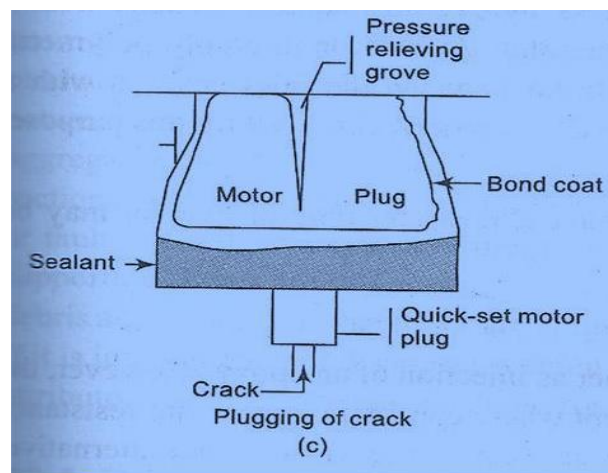

#### d) Crimped water bar

A crimped water bar arrangement at locations where the bar is not subjected to direct loads such as the traffic loads.

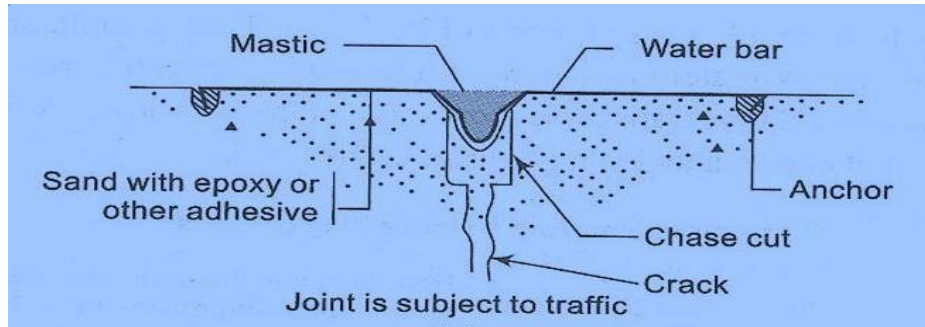

## 6. Grouting

Grouting is a process in which a fluid grout is pumped under pressure to fill forms, voids, and cracks. The technique is similar to the injection of an epoxy. The grouted mass has an increased strength, stiffness, and reduced permeability. Grout mixtures may contain cement and water or cement plus sand and water, depending on the width of the crack. However, the water-cement ratio should be kept as low as practical to maximize the strength and minimize shrinkage. After the crack is filled, the pressure should be maintained for several minutes to insure good penetration.

The steps involved in grouting are:

- cleaning the concrete along the crack
- installing built-up seats at intervals along the crack
- sealing the crack between the seats with a cement paint or grout
- flushing the crack to clean it and test the seal, and then allow it to dry
- then grouting the whole crack by forceful injection of the grout mix
- Allow the grout to set for some duration of time before reuse.

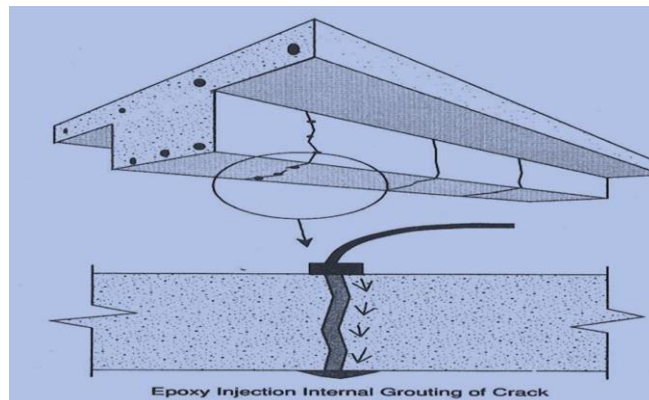

Its application includes;

- Reduce or fill the cracks or voids in the structural members
- Repairing the cracks in walls columns and other structural members
- Repairing the damage in the structural or masonry members
- For the honeycombing
- Making walls waterproof
- Avoiding seepage of water in stone masonries

This grouting method is effective in stopping water leaks, but it will not structurally bond cracked sections. It can be used in several settings including bridges, marine applications, dams, and rock anchors.

## 7. Overlays

- Overlays are used to seal cracks when a large number of cracks are present and treatment of each individual crack would be too expensive and laborious.
- Overlay is used to improve the abrasion resistance and for creating waterproofing barriers on the surface and act as protective coatings
- Overlays are surface depositions of 6 mm or greater in thickness that can be bonded, partially bonded, or unbonded to the surface of the concrete.
- The material of overlay may be polymer concrete, Portland cement concrete, epoxies, polyesters, and polymer-modified concrete.
- Overlay concrete change the appearance, texture, and elevation of the original concrete surface and a variety of different colors and finishes are available.
- Overlays may be placed, troweled, screeded, or sprayed in one or more layers onto the concrete surface.
- Overlays can be designed to act compositely with the existing structure and additional reinforcement in the form of welded-wire fabric, and reinforcing steel or fibers may be added.
- For an overlay to perform properly, the surface to which it is bonded should be clean, sound, and appropriately roughened.
- Bonded overlays are not used where there is active cracking or structural movement.

*For Active Cracks:* Sealing of active cracks by overlays should be done with a material, which is extensible but not flexible.

*For Dormant Cracks* almost any type of overlay (bonded, partially bonded, or unbonded) can be used.

*Polymer Overlays:* It comprises of one coat of primer and one or more coats of sealent.

*Epoxy Overlays:* It consists of resin and hardener. The strength gain is much faster than polymer overlays.

## 8. Autogenous Healing

*Autogenous healing is the natural process of healing of cracks that can occur in concrete in the presence of moisture, and the absence of tensile stress.*

Autogenous healing can be possible in following ways

A. Hydration of unhydrated particles of cement.

B.  $\text{CaCO}_3$  or  $\text{Ca}(\text{OH})_2$  formation to block cracks

C. Expansion/swelling of calcium-silicate hydrate (CSH) gel.

D. Blocking of cracks by presence of impurities in water.

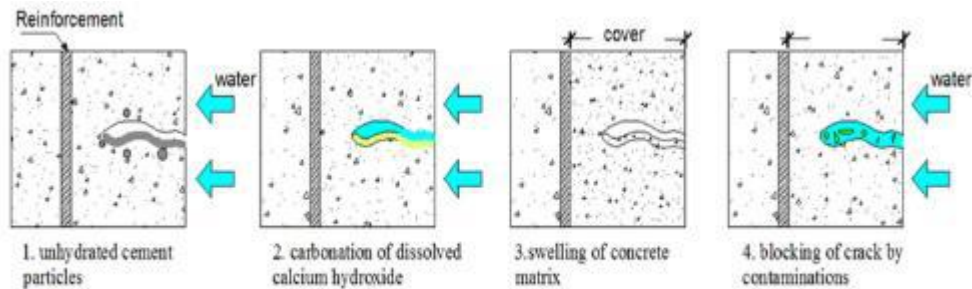

Four mechanisms of autogenous crack-healing in cementitious materials.

All mentioned processes can occur simultaneously. Moreover, some of the mentioned processes can only fill the cracks partially and leave the rest. Among all natural healing mechanisms formation of  $\text{CaCO}_3$  and  $\text{Ca}(\text{OH})_2$  is the most effective method

- In this mechanism, the carbonation of calcium oxide and calcium hydroxide in the cement paste by  $\text{CO}_2$  in the air and water.
- The resulting  $\text{CaCO}_3$  and  $\text{Ca}(\text{OH})_2$  crystals precipitate, accumulate, and grow through and out from the cracks.

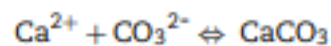
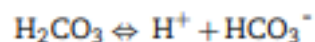

- The crystals produce a mechanical bonding effect which is supplemented by chemical bonding between adjacent crystals, and between crystals and the surfaces of the paste and aggregates.
- As a result some of the tensile strength is restored across the cracked section and the crack is sealed.
- This is used for sealing dormant cracks, repair of precast units cracked during handling, rectifying cracks developed during the driving of precast piling, sealing of cracks in water tanks and sealing of cracks which are the result of temporary loading conditions.

## **Repair of Spalling and Disintegration**

- 1) Placement of repair material
  - Form and Cast in place
  - Form and pump
- 2) Dry Packing
- 3) Prepacked concrete (Grout Preplaced Aggregate)
- 4) Pneumatically Applied Mortar
  - Dry Mix Shotcrete (Guniting)
  - Wet Mix Shotcrete
- 5) Replacement of concrete (Full depth repair)
- 6) Overlays
- 7) Protective surface treatments
- 8) Hand-applied treatment

### **Dry Packing**

Dry packing is the hand placement of a low water content mortar followed by tamping or ramming of the mortar into place, producing intimate contact between the mortar and the existing concrete

- Dry packing is a method of placing zero-slump, or near zero-slump, mortar or concrete into surface cavities.
- The usual mortar mix is 1:2.5 to 1:3
- Dry packing techniques can be used in all locations: overhead, vertical and flat.
- Best applications are generally small cavities such holes, small areas of surface honeycomb or rib bottoms.
- Each dry pack mortar repair is placed in layers. Compaction is achieved with a hardwood stick to prevent polishing of the surface.
- Curing is accomplished with a continuous 7-day moist cure.
- The consistency of dry pack mortar must be such that it can be molded into a ball without excessive bleeding.
- Compaction densifies the mortar and provides the necessary intimate contact with the existing concrete for achieving bond.



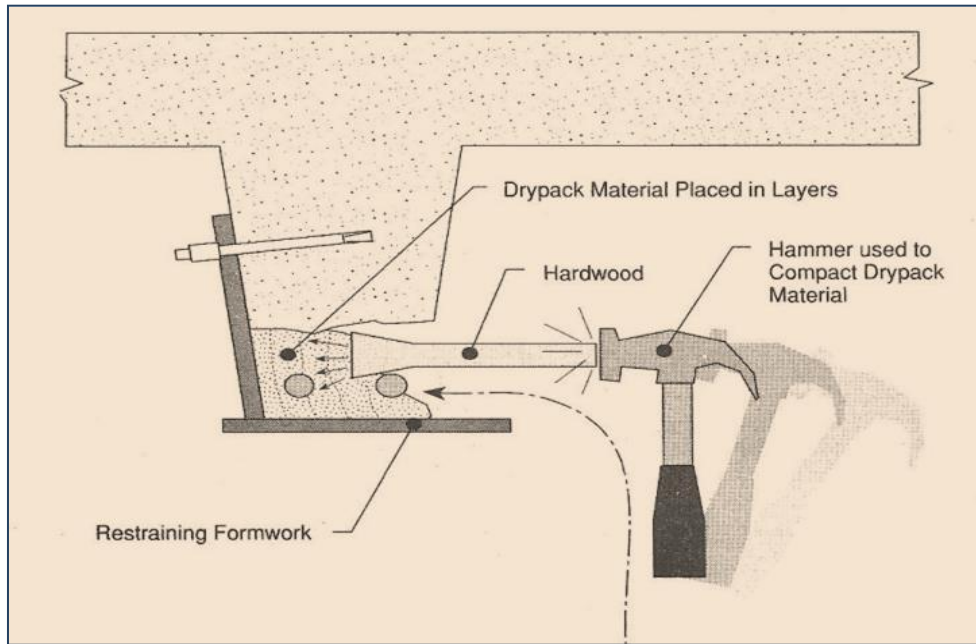

### **Prepacked concrete (Grout Preplaced Aggregate)**

*Prepacked concrete is made by filling forms with coarse aggregate and then filling the voids of the aggregate by pumping in a sand-cement grout.*

This method is particularly useful for carrying out the repair under water and elsewhere where accessibility is a problem.

- Grouted preplaced aggregate is a two-step process.
- The first step involves aggregate placement into the cavity during the erection of formwork.
- The aggregate is gap-graded and washed of all fines.
- The void ratio of the cavity after the aggregate is placed, ranges from 40% to 50%.
- The second step involves pumping a highly flowable grout through the formwork and into the preplaced aggregate.
- Grout flow fills the lower voids and progressively fills the cavity, eventually flowing to higher elevation ports.
- The process continues until the cavity is full and pressurized.
- The grout flow makes contact with the prepared substrate as the cavity is filled, providing intimate contact and bonding.
- A unique advantage of this method is the low drying shrinkage of the repair material due to the point-to-point contact between the coarse aggregates.
- Most popular are Portland cement- based grouts and, for special applications, epoxy resins.



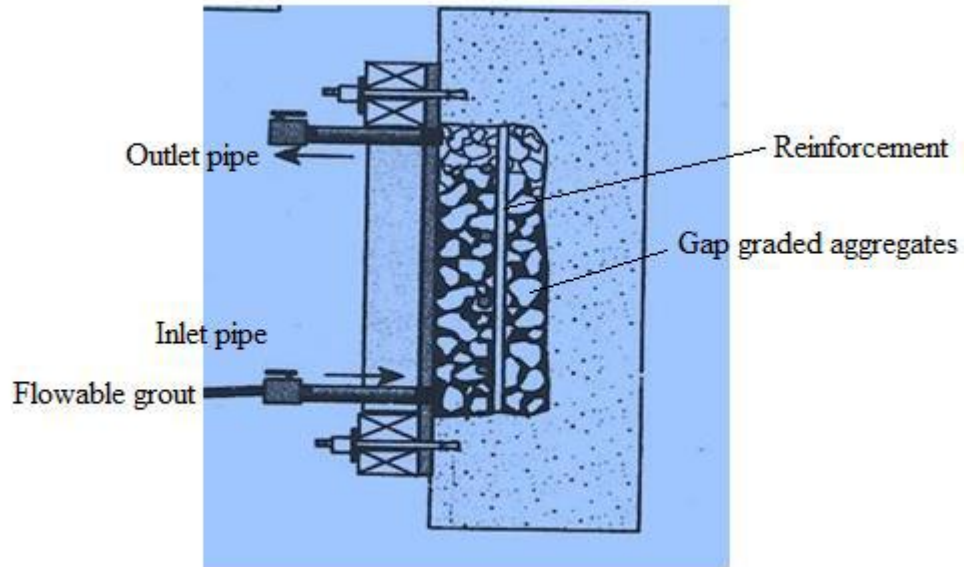

### Cathodic protection

- Cathodic protection is a method to control the corrosion of steel in contaminated concrete that works by making the embedded reinforcing steel as cathode.
- When the steel becomes cathode, hydroxyl ions are accumulated around it making it passive for longer time.
- The reinforcing steel is electrically connected to another metal that becomes the anode with or without the application of an external power supply.
  1. Sacrificial anode
  2. Impressed current

#### *1. Sacrificial anode*

- Less noble metals than steel like zinc or aluminium are connected with the steel bar and the dissolution of this anode metal provides current instead of an external power supply
- DC current is generated due to the potential difference between the steel to be protected (cathode) and the sacrificed metal (anode)

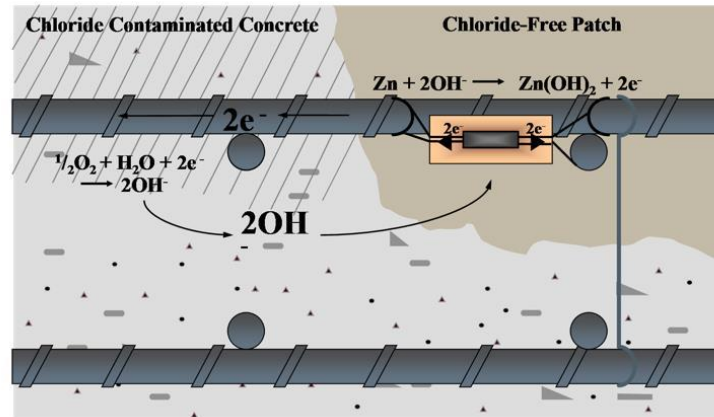

## 2. Impressed current

This system starts with the installation of permanent anode i.e. activated titanium mesh, after which a direct current is provided in the structure via this permanent anode and external power supply.

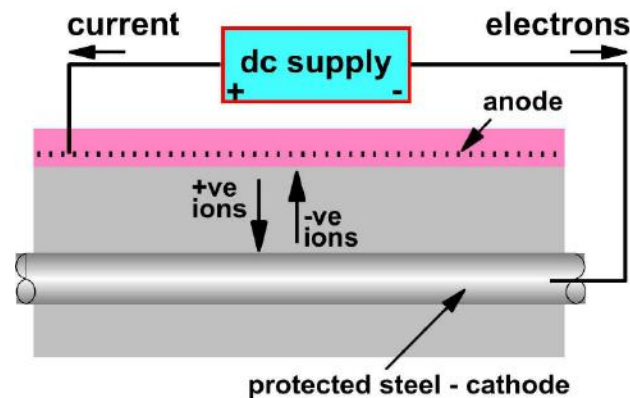

- Cathodic protection is used to protect almost any type of reinforced concrete structure, including horizontal slabs, walls, towers, beams, columns and foundations.
- *Limitations:*
  - Cathodic protection does not replace corroded steel
  - Impressed current cathodic protection systems are not recommended for prestressed concrete structures because hydrogen produced can make the high-strength steels brittle in nature
  - Sacrificial anode systems can be used for post-tensioned structures after detailed corrosion analysis
  - Electrical continuity of the reinforcing steel and ionic conductivity of concrete must be confirmed during system installation.

## **PNEUMATICALLY APPLIED MORTAR:**

Mortar or concrete is conveyed through a hose and pneumatically projected at high velocity onto a surface to be freshly constructed or to be repaired.

There are two procedures of placing concrete pneumatically:

- A) Guniting or Dry Mix Shotcrete
- B) Wet Mix Shotcrete

### **A) Dry Mix Shotcrete or Guniting:**

- Dry mix shotcrete is a method that involves the premixing of binder and aggregates and fed into a special mechanical feeder metering the premixed materials into a hose.
- The material is conveyed through the hose with compressed air to a nozzle which is outfitted with a water pipe where water is mixed with the binder and aggregates.
- The mix is jetted from the nozzle at high velocity onto the prepared concrete surfaces.
- The process demands expertise and responsibility of the worker (nozzle operating man).
- Nozzle operating man has much better control over the w/c ratio than compared to the wet mix process.
- The process varies, depending upon the necessary thickness and orientation.
- Where the repair is thick, the process may involve the placement of multiple layers.
- Excessive thickness of individual layers may result in sloughing off.
- The use of special admixtures has helped improve the workability and performance of shotcrete.

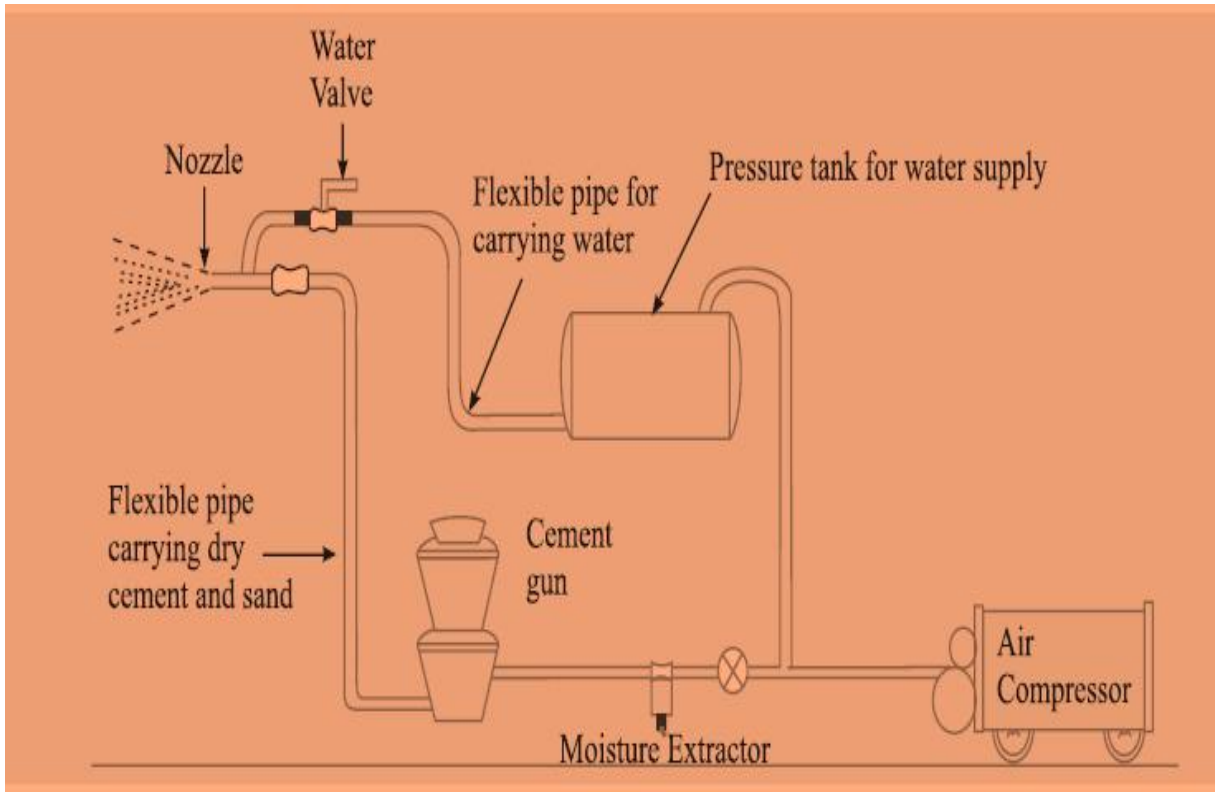

#### *Advantage*

- Generally Higher Compressive Strengths
- Nozzleman Can Adjust Water For Better Adherence in Wet Substrate Conditions
- Available in Premixed Dry Bags Form for Stop- Start Type Work
- Greater Thickness of Application Possible on Vertical and Overhead Surfaces

#### *Disadvantages*

- Higher Rebound
- More Dust
- Larger Air Compressor Required
- High Level of Nozzleman Skill Required
- Potential for Laminations, sand lenses, dry pockets, etc.
- Lower volume rates of placement

#### **b) Wet Mix Shotcrete:**

- Wet mix shotcrete is a method that involves premixing of all ingredients (except accelerators) including binder, aggregates, admixtures, and mixing water.
- The premixed repair materials are deposited into a pump or pressure vessel which transports the materials to an exit nozzle, where compressed air is introduced.
- The repair material is propelled onto the substrate with compressed air.
- Admixtures can be used to enhance the shotcrete material.
- Silica fume and fibers are commonly used to enhance durability.

- Air entrainment is required for freeze-thaw resistance.

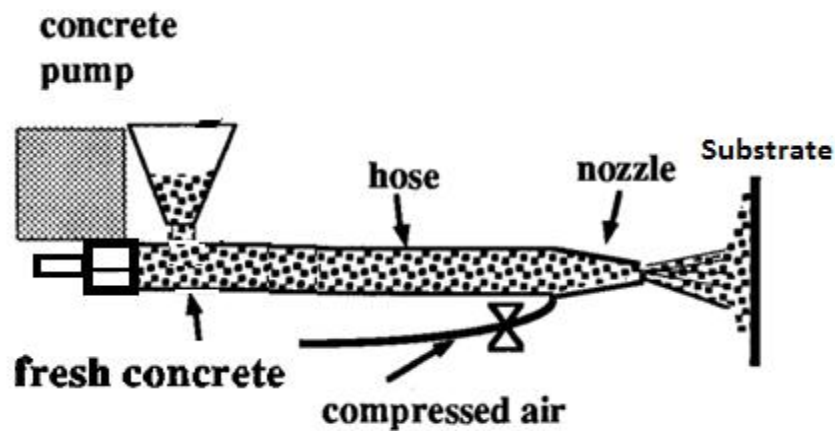

#### *Advantages*

- Less Rebound
- Less Dust
- Less Nozzleman Skill Required
- Lower Cost Ready Mix Supply Often Possible

#### *Disadvantages*

- Generally Lower Compressive Strengths
- Cannot Adjust Moisture Content at Nozzle when Shooting Wet Areas
- Restricted to Layers 2 to 3 inches thick in a single pass
- Not suitable for small work

### **Repairs in Under Water Structures**

**The special features of underwater repairs are as follows:**

1. The underwater repairs are more complex and highly costly. Hence the repair operations should be as simple as possible. The choice of technique depends on the available mode of access to the damaged area.
2. The adequate preparation of the damaged area may need special technique to be adopted.
3. The repair materials must be compatible with under water use both during placing and curing. Cementitious materials have been found to be better suited for under water repair.
4. Form work and placement method adopted should be such that the mixing of repair material with the water should be minimum.
5. The supervision of underwater repair is costly and difficult.

### **Methods of repairing structures in under water**

- a. Surface Spalling Repair
- b. Preplaced Aggregate Concrete
- c. Injection Technique

#### d. Steel Sleeve Repairing Technique

##### a. Surface Spalling Repair

- The areas which are already slightly deteriorated with time, will be prone to severe and dangerous damage in a short period of time.
- Before starting the repairing procedures, the damaged area must be cleared off of the marine growth and the loose concrete.

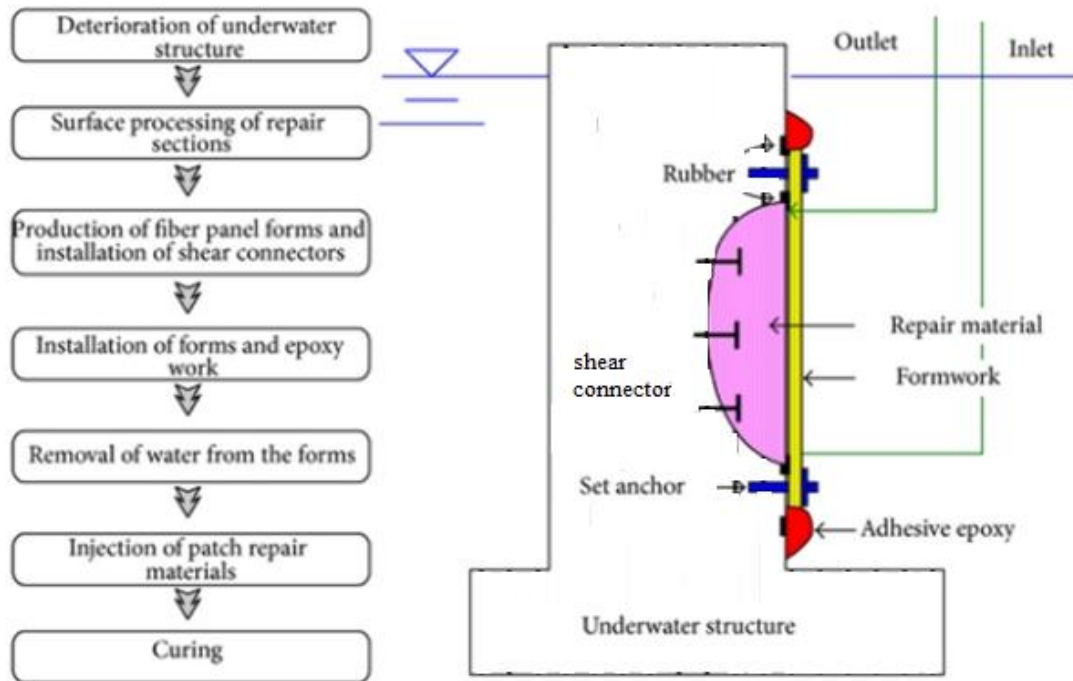

- After the damaged area is cleared, the boundary of the spalled area should be cut to a depth of about 10-20 mm depending on the amount of damage done.
- The spalled areas are repaired by the application of the cementitious mortar and in case of small damage area, the epoxy mortar can be utilized.
- For large area of damage, formwork should be used to hold the repair material in its place which could delay the enhancement work.

##### b. Preplaced Aggregate Concrete

- In this type of repair, formwork is installed in the area to be repaired and a gap graded aggregate is compacted in it.
- Before placing the grout in the aggregate, it is ensured that the aggregate is cleaned with the help of freshwater.
- Then, specific grout is injected
- The water and voids which are present in the aggregate are expelled out by the grout.
- The formwork which is placed at the damaged area, should be grout proof to avoid the leakage.
- Furthermore, there should be proper venting so as to help the voids and air to escape.
- It is of great significance that the aggregates fill the formwork till the top of damage region.

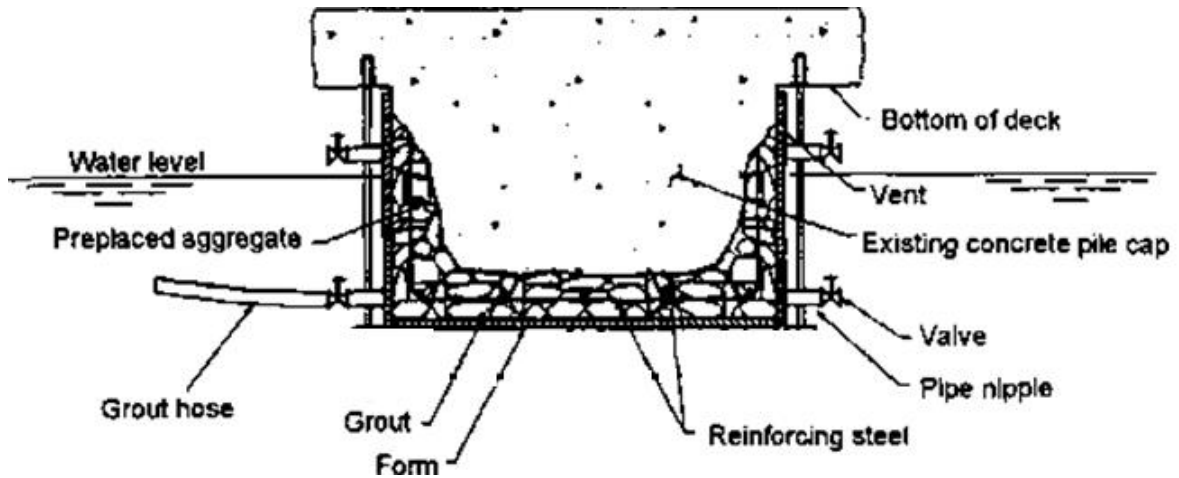

### c. Injection Technique

- This type of repair is similar to the procedure used for repairing the dry structures where injection of cementitious grout or resin can be employed to repair cracks and or voids.
- The selection for the material depends on the void or crack size and also on the possibility of the predicted displacement of the member in the future.
- Epoxy resin is employed for a crack width of 0.1mm
- Cement grout is used when the crack width is greater than few millimeters.

The procedures for injection techniques are

- Prepare concrete surface along the crack length
- Along the crack length, fix inspection nipples at specific intervals
- Seal crack surface along the whole length of the crack
- Remove contamination using fresh water and be sure that the injection path is open
- At one end of the crack, inject epoxy resin or cement grout into the crack through the nipples

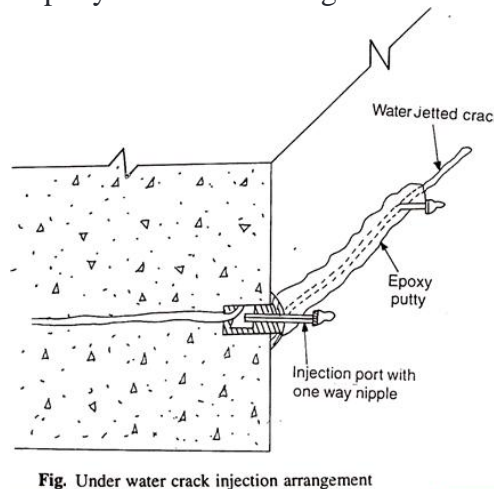
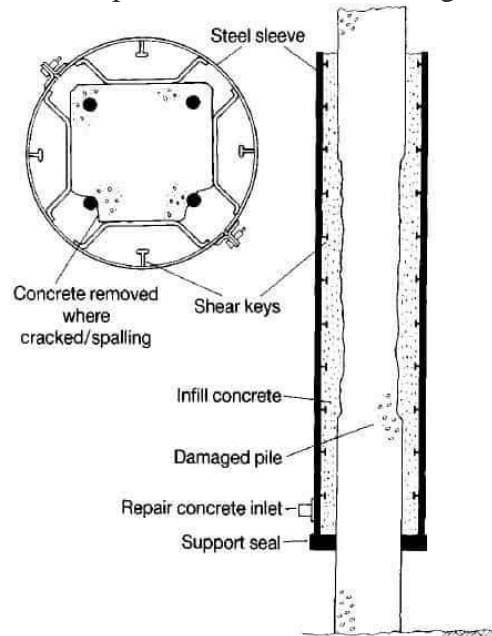

Fig. Under water crack injection arrangement

### d. Steel Sleeve Repairing Technique

- This type of repair employs a steel sleeve which is used around a pile or column.
- Then the space between the sleeve and pile or column is filled with mortar or concrete.
- The steel sleeve should be designed such that there should be enough space for further reinforcement corrosion.

- The sleeve needs to exceed the top and bottom of the damaged length of the pile



A steel sleeve repair technique procedure is as follows

- Prepare the damaged pile with loose concrete and marine growth
- Clamp a temporary support or sealing ring around the pile below the area of the damage
- Both the two semi-circular sections of the sleeve
- Pump grout or cement at the bottom of the sleeve
- Remove the temporary support and employ corrosion protection to the steel sleeve

Prepared by

Dr K Thulasirajan MTech Ph.D

Associate Professor

AITS, Tirupati



## Unit V

### Strengthening techniques

Strengthening techniques for structural members -Underpinning- Jacketing- Plate bonding- Fibre Wrap Technique- Composite construction- Post-Tensioning-Steel bracing

#### **Retrofitting**

Retrofitting is a method to improve the performance of structures that have lost strength due to degradation or have reached the end of their expected life.

#### ***Purpose of Retrofitting***

1. Buildings whose serviceability or strength are insufficient to meet the requirements of structural rules or regulations due to overuse, poor maintenance, or aging materials and constructions.
2. Buildings with quality or safety issues as a result of design errors or poor construction quality.
3. Structures damaged by disasters such as earthquakes and other natural disasters.
4. Restoration of historic and memorial structures.
5. The structures that will be renovated or have new stories added to them.

#### **Foundation Rehabilitation Method**

The methods to repair and rehabilitate a structure having foundation distress generally involve underpinning work for structures that are out of plumb, or are sensitive to effects of small settlement etc

#### **Underpinning**

Underpinning is the process of strengthening the foundation of an existing building or other structure.

#### ***Purpose of Underpinning***

- To strengthen a shallow foundation
- To strengthen an existing foundation, which has suffered from cracks and settlements
- To deepen an existing foundation.
- To construct a basement under an existing building.

#### ***Types***

- a. Pit method
- b. Pile method
- c. Micro-piles
- d. injection of the ground with cement or chemicals

#### ***a.Pit method***

In this method, the entire length of the foundation to be underpinned is divided into sections of 1.2 to 1.5 m lengths. One section is taken up at a time. First of all, a hole is made in the wall for all divided sections above the plinth level, and needle is inserted in the hole. The needle may be made of a material of timber or steel section.

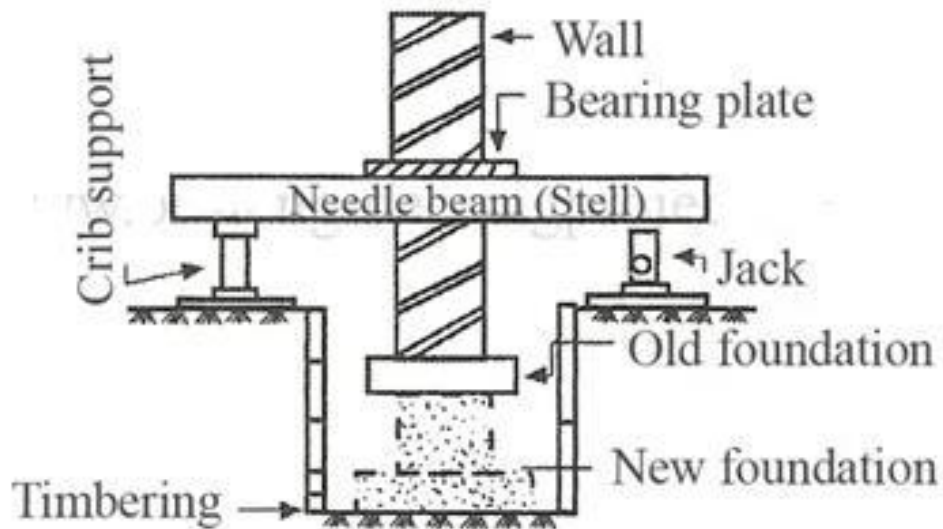

***b. Pile method***

In this method, piles are driven on adjacent sides of the wall that supports the weak foundation. A needle or pin penetrates through the wall that is in turn connected to the piles. These needles behave like pile caps.

*Application*

- i) Waterlogged area
- (ii) Heavy loads on existing structures
- (iii) Loads to be transferred to a deeper depth

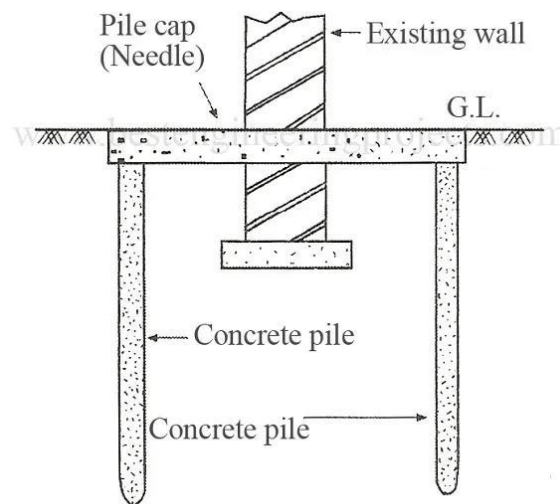

***c. Micro-piles***

- Micro-piles are a useful means of underpinning.
- They can be installed from the ground surface without deep excavation and the equipment in installing the piles is suitable for working in confined spaces.
- This method can be implemented where the loads from the foundation have to be transferred to strata located at a distance greater than 5m.

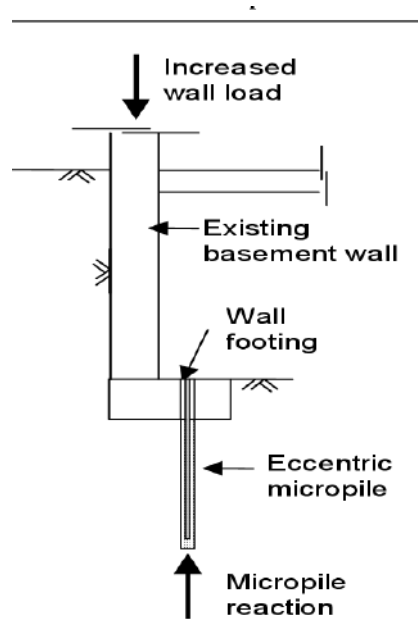

***d. Underpinning by injection of the ground with cement or chemicals***

Underpinning by injection of the ground with cement or chemicals to fill voids or to permeate and strengthen the ground.

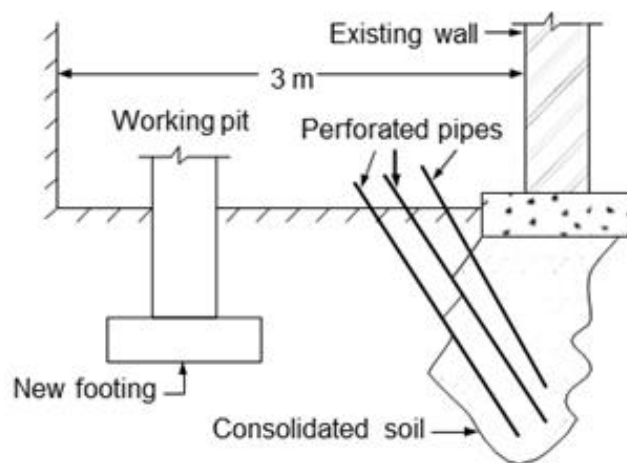

**Strengthening methods in structural members**

Strengthening is the process of adding the capacity to the member or structure

1. Jacketing
2. Plate bonding
3. FRP Technique
4. Composite construction
5. Post-Tensioning

# **1. Jacketing**

Jacketing is a method of strengthening the structural members. **Jacketing** is the process whereby a section of an existing structural member is restored to original dimensions or increased in size by encasement using suitable materials.

## ***a) Column jacketing***

RC columns can best be strengthened by jacketing, and by providing additional cage of longitudinal and lateral tie reinforcement around the columns and casting a concrete ring, so that desired strength and ductility can thus be built-up. The steps in the column jacketing are as follows

Step-1: Support the structure using props, in order to relieve the stress on the RCC structural member.

Step-2: Remove plaster and finishes all around the distressed RCC structural member. Thereafter remove loose, cracked and spalled concrete to expose the rusted reinforcement

Step-3: Remove concrete all around the reinforcement in order to get average air gap all around the reinforcement & clean the reinforcement from rust

Step-4: Put additional reinforcement wherever the reinforcement diameter has been reduced by more than 15%

Step-5: Fix shear key bars for column/ Fix additional stirrups for beam

Step-6: Bond coat shall be applied over the prepared

Step-7: Within the less period of bond coat, shuttering and concreting shall be done. The consistency of this concrete shall be flowing

Step-8 Wet curing shall be done over the finished surface

Step-9: After RCC columns/beams are cured and completely dried, a protective coating shall be applied

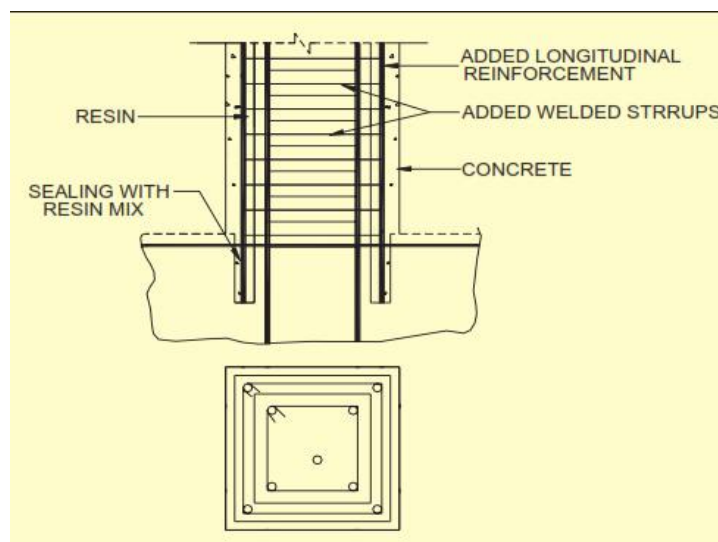

## ***b) Beam jacketing***

Jacketing a reinforced concrete beam can also be done in the above manner.

The steps in the beam jacketing are as follows

Step-1: Remove plaster and finishes all around the distressed RCC structural member. Thereafter remove loose, cracked and spalled concrete to expose the rusted reinforcement

Step-2: Remove concrete all around the reinforcement in order to get average air gap all around the reinforcement & clean the reinforcement from rust

Step-3: Put additional reinforcement wherever the reinforcement diameter has been reduced by more than 15%

Step-4: Fix additional stirrups for beam. For holding the stirrup, holes will have to be drilled through the slab.

Step-5: Bond coat shall be applied over the prepared

Step-6: Within the less period of bond coat, shuttering and concreting shall be done. The consistency of this concrete shall be flowing

Step-7: Wet curing shall be done over the finished surface

Step-8: After RCC columns/beams are cured and completely dried, a protective coating shall be applied

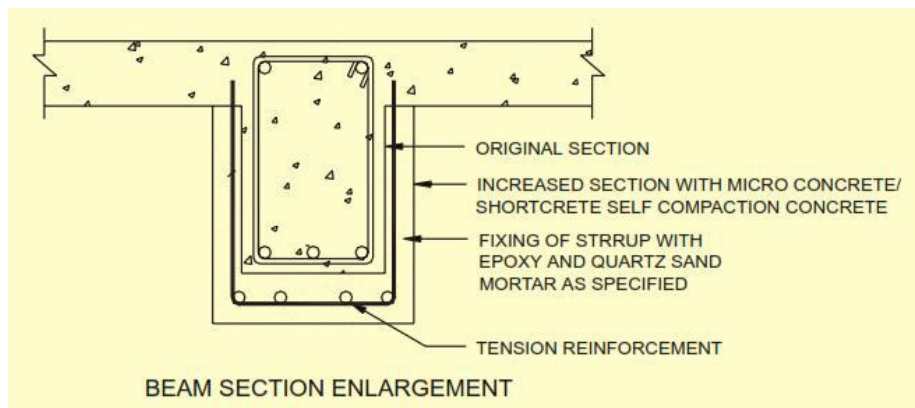

### c) *Beam column joint jacketing*

- For jacketing the beam column joint, the surface was cleaned for removal of dirt, had their sharp edges chipped off, and their surfaces roughened for facilitating bonding between old and new concrete.
- A reinforcement cage was placed around the joint region and concreting was carried out with high performance fibre-reinforced concrete.

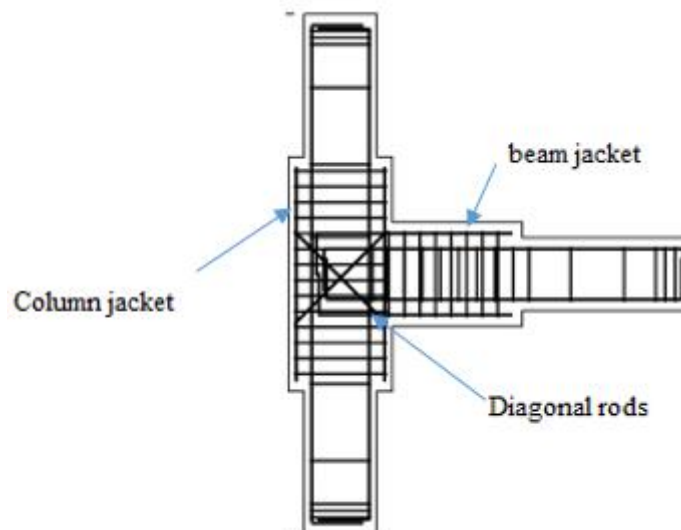

## 2. Plate bonding

Steel plate bonding reinforcement method has been widely used in strengthening engineering, its basic principle is using high performance epoxy adhesive bonded the steel plate to the concrete, so as to form a unified whole, to achieve the purpose of strengthening and enhancing the strength and stiffness of the original structure.

- Plate bonding is an inexpensive, and versatile and advanced technique for rehabilitation, up gradation of concrete structures by mechanically connecting Mild Steel plates by bolting and gluing to their surfaces with epoxy.
- Plate bonding can substantially increase strength, stiffness, ductility and stability of the reinforced concrete elements and can be used effectively for seismic retrofitting.

### **Procedure for plate bonding**

- The bolts, which are first used to hold plates in position during construction, act as permanent shear connectors and integral restraints.
- The bolts are also designed to resist interface forces assuming the epoxy glue used as non existent assuming it as destroyed by fire, chemical break down, rusting or simply bad workmanship.
- Since epoxy is prone to premature debonding, use of mechanical anchorage along with epoxy binding is considered more reliable.

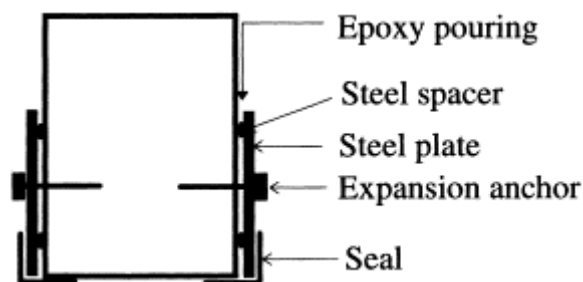

### **a) Plate bonding of column**

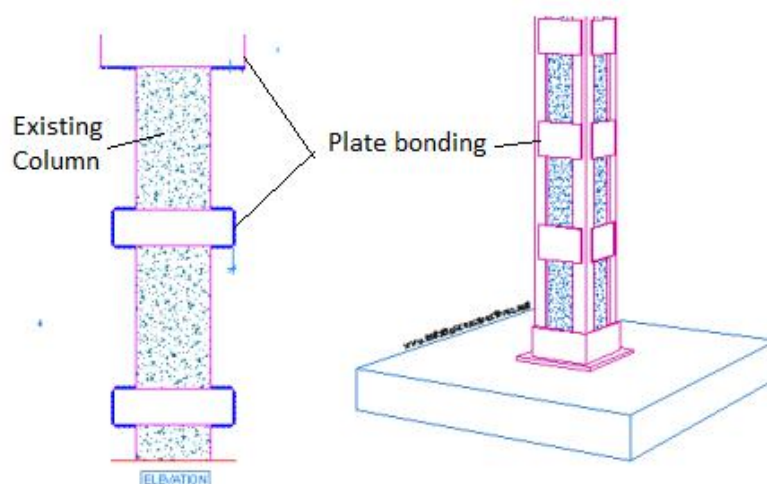

## b) Plate bonding in beam

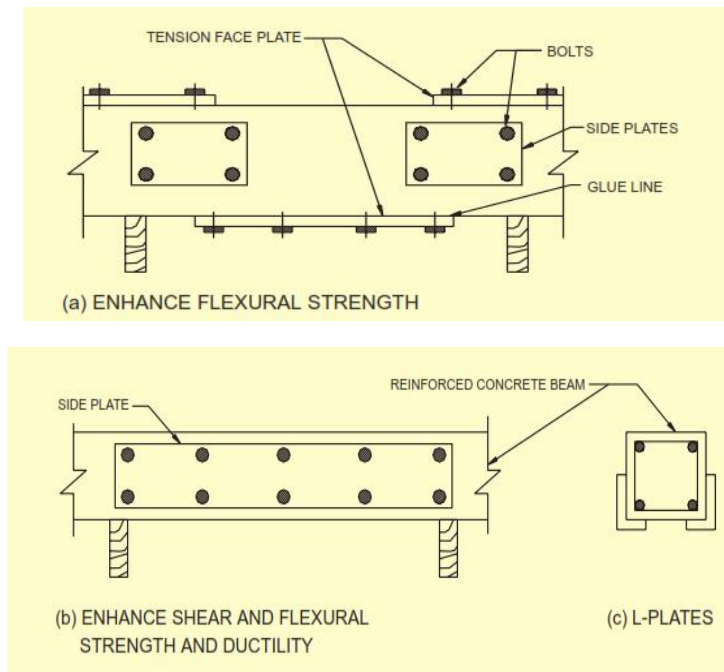

## 3. Fibre Wrap Technique

The fibre wrap technique, also known as Composite Fiber System is a structural strengthening technique that increases the load carrying capacity (shear, flexural, compressive) and ductility of reinforced concrete members without causing any destruction or distress to the existing concrete. Fibre-reinforced polymers (FRP) are composed of fibres and a polymer matrix. The constituent materials used in commercially available FRP repair systems, including all resins, primers, putties, saturants, adhesives, and fibers, have been developed for the strengthening of structural concrete members based on materials and structural testing.

*Resins:* Commonly used resin types, including epoxy, vinyl esters, and polyesters, have been formulated for use in a wide range of environmental conditions.

*Primer:* Primer is used to penetrate the surface of the concrete, providing an improved adhesive bond for the saturating resin or adhesive.

*Putty fillers:* Putty is used to fill small surface voids in the substrate, such as bug holes, and to provide a smooth surface to which the FRP system can bond.

*Saturating resin:* Saturating resin is used to impregnate the reinforcing fibres, fix them in place, and provide a shear load path to effectively transfer load between fibres.

*Adhesives:* Adhesives are used to bond precured FRP laminate and Near-surface-mounted systems to the concrete substrate. The adhesive provides a shear load path between the concrete substrate and the FRP reinforcing system.

*Fibers:* Continuous glass, aramid, and carbon fibres are common reinforcements used with FRP systems. The fibres give the FRP system its strength and stiffness.

*Protective coatings:* The protective coating protects the bonded FRP reinforcement from potentially damaging environmental and mechanical effects. These include:

- Polymer coatings;
- Acrylic coatings
- Cementitious systems

### ***Common procedure for installation of FRP***

- Primer should be applied to all areas on the concrete surface where the FRP system is to be placed. The primer should be placed uniformly on the prepared surface
- The applied primer should be protected from dust, moisture, and other contaminants before applying the FRP system.
- Putty should be used in an appropriate thickness and after the application of primer.
- The system-compatible putty, which is typically a thickened resin-based paste, should be used only to fill voids and smooth surface discontinuities before the application of other materials.
- If the putty and primer are fully cured, additional surface preparation may be required before the application of the saturating resin or adhesive.
- The saturating resin should be applied uniformly to all prepared surfaces where the system is to be placed.
- The fibres can also be impregnated in a separate process using a resin-impregnating machine before placement on the concrete surface.
- The reinforcing fibers should be gently pressed into the uncured saturating resin
- Entrapped air between layers should be released or rolled out before the resin sets.
- Successive layers of saturating resin and fiber materials should be placed before the complete cure of the previous layer of resin.
- There are various types of wrapping styles in the external bonding of FRP. They are fully wrapped in style, with strip type wrapping at various angles like 0°, 45°, 90°, and U-wrapping style.

### ***FRP for Column***

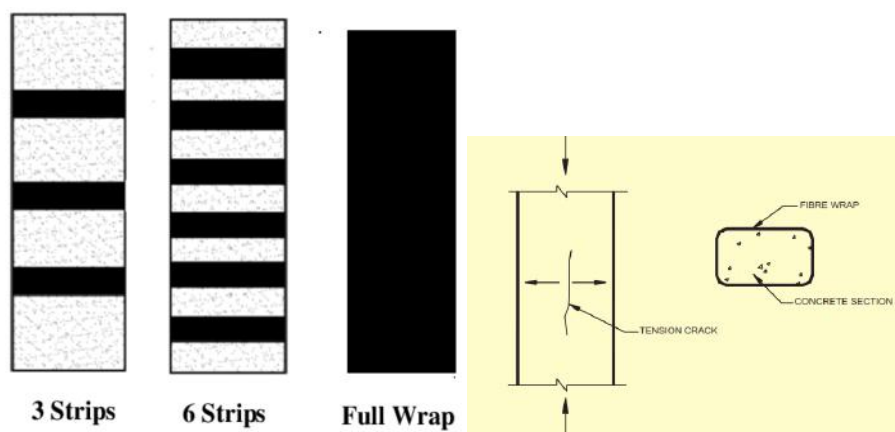



### FRP for beam

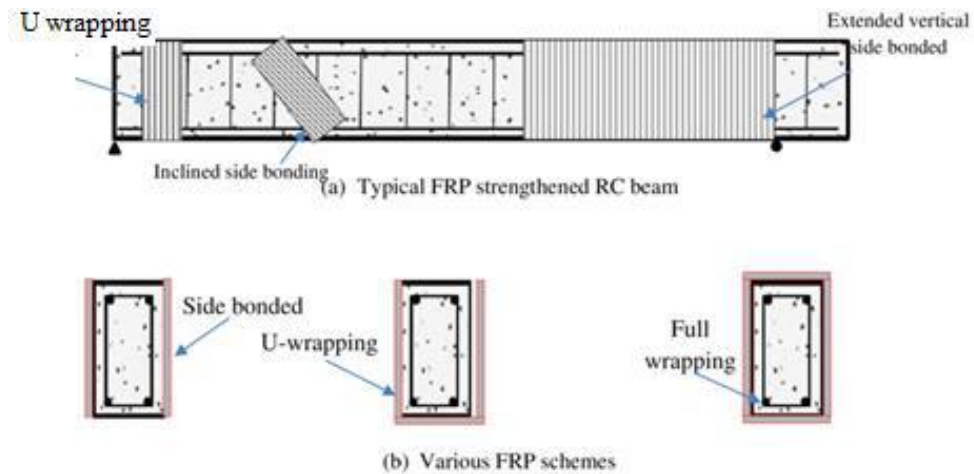

### FRP for beam column joint

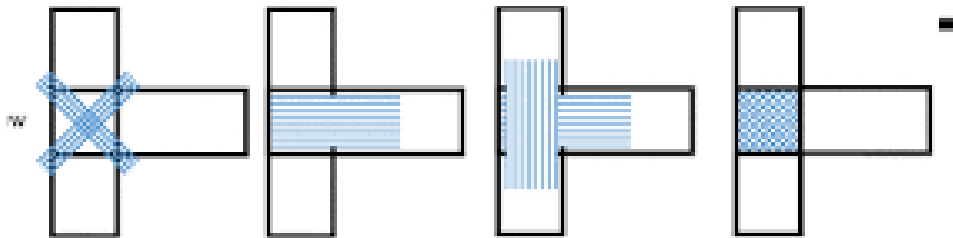

### FRP for slabs

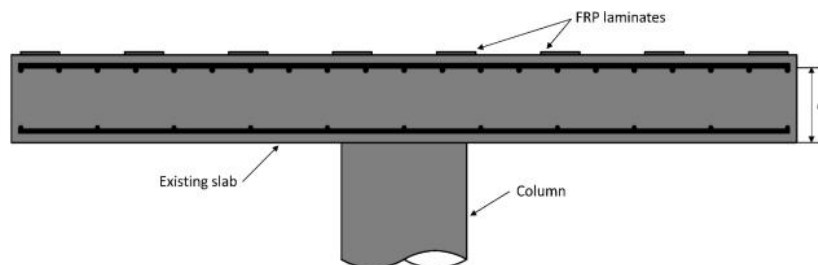

### Advantages of FRP wrapping:

- Multifunctional can be used in bending and in shear
- Low in weight
- Available in any length
- Flexible, fits around any given structural element
- Excellent chemical and weathering resistance
- Low overall thickness
- Economic application
- Easy to use solvent free impregnating resin

### ***Application of FRP***

1. Reinforcement of concrete columns by wrapping FRP sheets to prevent buckling of the reinforcement
2. Flexural strengthening of beam and slab or deck of bridges and buildings
3. Shear strengthening of beam
4. Wrapping damaged bridge piers to prevent collapse

### **4.Composite Construction**

- Composite construction is a method wherein materials other than concrete are placed in concrete with an existing concrete member to add stiffness or load carrying capacity.
- Steel is the most common material used in this technique.
- Steel plates and structural shapes can be fabricated to meet almost any configuration requirement.
- Load transfer in the composite member is accomplished by the use of adhesives, grouts, and mechanical anchorage systems.
- Improves the strengthening against punching shear failure

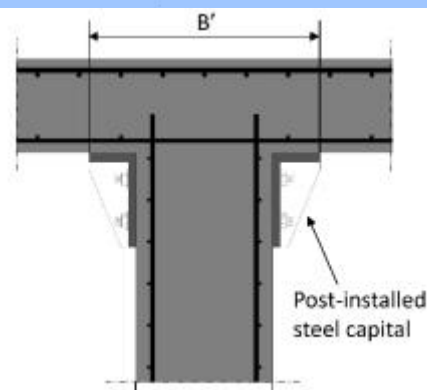
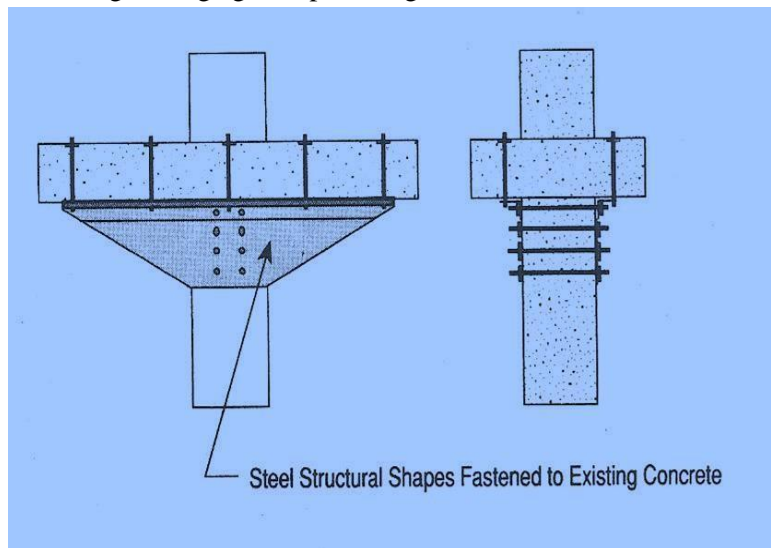

### **5.Post-Tensioning**

- Post-tensioning is a technique used to prestress reinforced concrete.
- The tensioning provides the member with an immediate and active load-carrying capability.

- Placement of the tension components can be achieved either internally within the member or externally to the member.
- Tension components are generally steel plates, rods, tendons or strands.
- Tension is imparted to the components by jacking or, less commonly, by preheating.
- Post-tensioning enhances a member's ability to relieve overstressed conditions in tension, shear, bending, and torsion.
- The post-tensioning technique can also be used to eliminate unwanted displacements in members and to turn discontinuous members into continuous members.

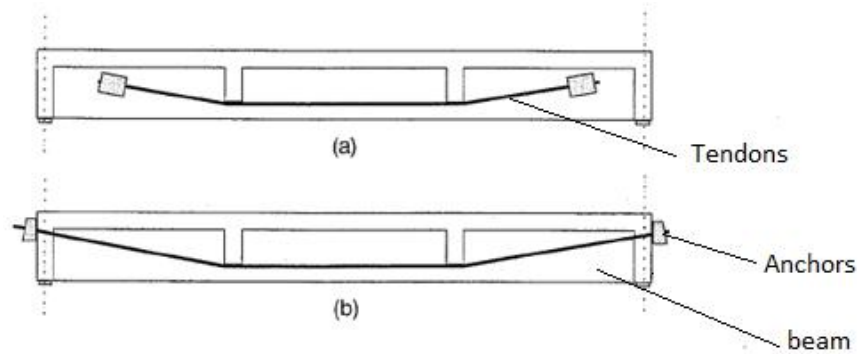

Flexural strengthening of beams using post tension method

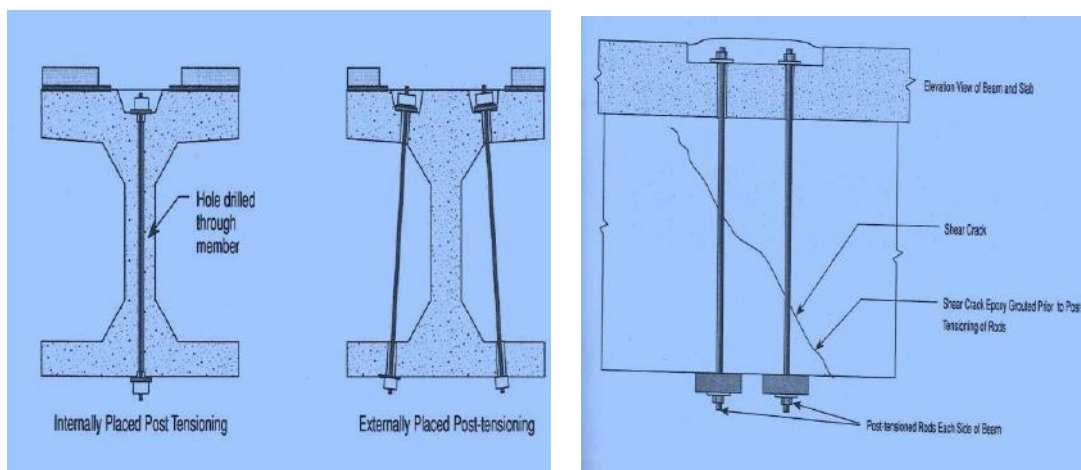

Shear strengthening of bridge girder and beams using post tension method

### Steel bracing

Steel bracing retrofitting is a structural engineering technique used to enhance the seismic resistance and overall stability of existing structures, particularly in areas prone to earthquakes. It involves adding steel braces, also known as steel frames or steel diagonal members, to the structure to increase its lateral stiffness and ability to dissipate seismic forces.

The primary objectives of steel bracing retrofitting are:

**Seismic Performance Improvement:** The addition of steel braces enhances the building's capacity to resist lateral loads caused by earthquakes, reducing the potential for structural damage or collapse during seismic events.

**Strengthening Existing Structures:** In some cases, older buildings may not have been designed to withstand modern seismic forces. Steel bracing retrofitting strengthens these structures to meet current seismic design codes and standards.

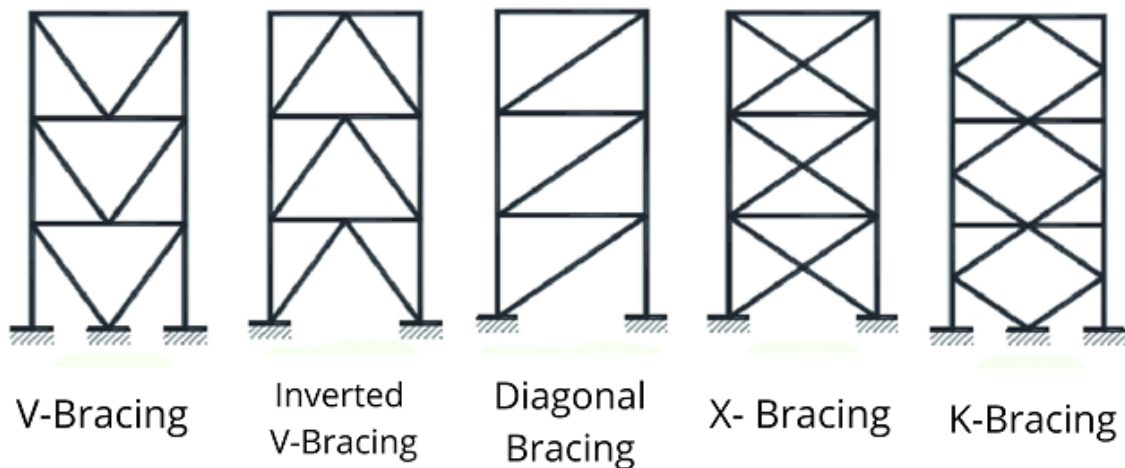

**The steel bracing retrofitting process typically involves the following steps:**

**Structural Assessment:** A detailed assessment of the existing structure is conducted to identify its vulnerabilities and determine the retrofitting requirements. This assessment includes evaluating the building's materials, design, and current condition.

**Retrofit Design:** Structural engineers design the steel bracing system based on the building's specific needs and seismic performance objectives. The design considers factors such as the building's configuration, loads, and potential failure modes.

**Bracing Installation:** Steel braces are installed at strategic locations within the building to provide additional lateral strength. The braces are typically placed diagonally between floors or from the foundation to upper levels, forming a bracing frame.

**Connection Details:** Proper connection details between the steel braces and the existing structure are critical to ensure efficient load transfer and prevent potential weak points.

**Anchoring and Fixing:** Bracing members are anchored securely to the building's structure and foundation using appropriate methods to withstand the anticipated forces.

**Quality Control:** Rigorous quality control measures are implemented throughout the retrofitting process to ensure that the installation meets engineering specifications and safety standards.

Steel bracing retrofitting is commonly used in various types of structures, including:

- Multi-story buildings, such as commercial buildings and apartments.
- Industrial facilities, like warehouses and manufacturing plants.
- Infrastructure, such as bridges and elevated highways.

## Repair/Rehabilitation/retrofitting Strategies

- 1) Stress Reduction
- 2) Repair/strengthening of Columns, beams and slabs
- 3) Improving the compressive strength of concrete.
- 4) Attending to Cracks and joints
- 5) Improving the masonry structure to be able to resist earthquake forces
- 6) Providing protective cover against the aggressive deteriorating chemicals

### **Repair/Strengthening Columns, Beams and slab**

#### ***Columns:***

- **Load carrying capacity:** Jacketing
- **Ductility/confinement:** steel plate bonding, and fibre wrap.
- **Joints: Composite construction,** jacketing and fibre wrap

#### ***Beams:***

##### **a. Flexural Strength**

- Section enlargement in compression (Jacketing),
- External Post-tensioning.
- MS plate bonding
- Fibre Fabric Wrap Technique (without section enlargement)

##### **b. Shear Strength:**

- Jacketing
- external post-tensioning
- internal post-tensioning
- Plate bonding
- Fibre wraps

#### **Slabs:**

- FRP wrapping
- Overlays

The performance of the slab can be improved by providing overlays (in case of negative moment deficiency) or underlay (in case of positive moment deficiency). The addition of overlay/underlay will also increase the stiffness of the slabs and control the excessive deflections problems. The slabs are generally safe in shear and as such no need is likely to occur for shear strengthening except flat slabs near column capital.

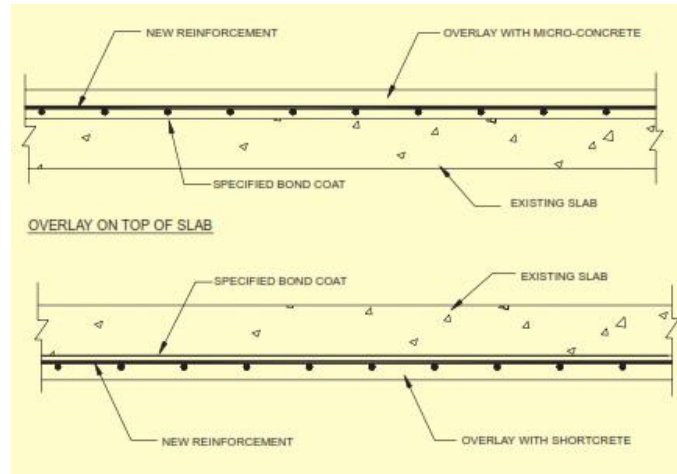

### Wall strengthening by post-tensioning

- A Horizontal compression state induced by horizontal tendons can be used to increase the shear strength of walls.
- Moreover this will also improve considerably the connections of orthogonal walls, The easiest way of affecting the precompression is to place two steel rods on the two sides of the wall and strengthening them.
- Note that good effects can be obtained by slight horizontal prestressing (about 0.1 MPa) on the vertical section of the wall.

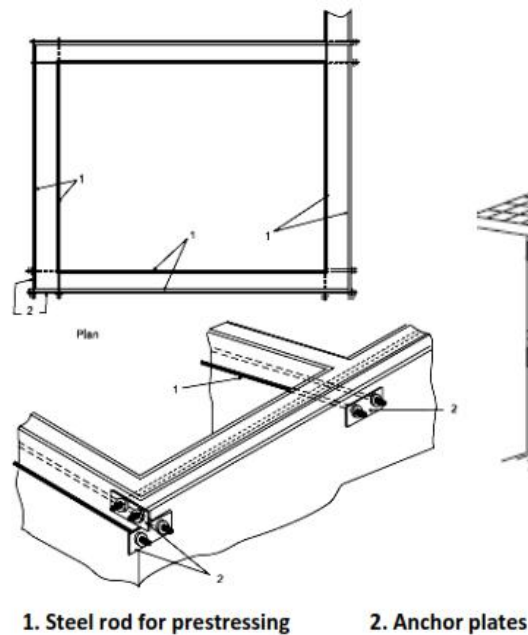

Prepared by  
 Dr K Thulasirajan MTech Ph.D  
 Associate Professor  
 AITS, Tirupati