



ANNAMACHARYA INSTITUTE OF TECHNOLOGY & SCIENCES :: TIRUPATI
(AUTONOMOUS)
Karakambadi Road, Venkatapuram (Vi), Tirupati.



Dept. of Mechanical Engineering

Subject	: Engineering Graphics Digital Notes
Academic Year	: 2023-24
Department	: Mechanical Engineering
Year & Sem	: I B. TECH & I/II SEM

Year: I

Semester: I/II

Branch of Study: Common to all Branches

Subject Code	Subject Name	L	T	P	Credits
23AES0301	Engineering Graphics	1	0	4	3

Course Outcomes:

- CO: 1 Apply the concepts of engineering curves and scales for technical drawing.
- CO: 2 Understand the quadrant system to locate the position of points, lines and planes.
- CO: 3 Analyze the projection of solids located in quadrant system.
- CO: 4 Analyze the sectional views and development of surfaces of regular solids.
- CO: 5 Apply orthographic and isometric projections concepts to construct the given object

CO	Action Verb	Knowledge Statement	Condition	Criteria	Blooms level
CO1	Apply	the concepts of engineering curves and scales	for technical drawing		L3
CO2	Understand	the quadrant system to locate the position of points, lines and planes			L2
CO3	Analyze	the projection of solids	located in quadrant system		L4
CO4	Analyze	the sectional views and development of surfaces	of regular solids		L4
CO5	Apply	orthographic and isometric projections concepts to construct the given object			L3

Unit I: Introduction: Lines, Lettering and Dimensioning, Geometrical Constructions and Constructing regular polygons by general methods.

Curves: construction of ellipse, parabola and hyperbola by general, Cycloids, Involute, Normal and tangent to Curves.

Scales: Plain scales, diagonal scales and vernier scales.

Unit II

Orthographic Projections: Reference plane, importance of reference lines or Plane, Projections of a point situated in any one of the four quadrants.

Projections of Straight Lines: Projections of straight lines parallel to both reference planes, perpendicular to one reference plane and parallel to other reference plane, inclined to one reference plane and parallel to the other reference plane. Projections of Straight Line Inclined to both the reference planes

Projections of Planes: regular planes Perpendicular to both reference planes, parallel to one reference plane and inclined to the other reference plane; plane inclined to both the reference planes.

Unit III

Projections of Solids: Types of solids: Polyhedra and Solids of revolution. Projections of solids in simple positions: Axis perpendicular to horizontal plane, Axis perpendicular to vertical plane and Axis parallel to both the reference planes, Projection of Solids with axis inclined to one reference plane and parallel to another plane.

Unit IV

Sections of Solids: Perpendicular and inclined section planes, Sectional views and True shape of section, Sections of solids in simple position only.

Development of Surfaces: Methods of Development: Parallel line development and radial line development. Development of a cube, prism, cylinder, pyramid and cone.

Unit V

Conversion of Views: Conversion of isometric views to orthographic views; Conversion of orthographic views to isometric views. **Computer graphics:** Creating 2D&3D drawings of objects including PCB and Transformations using Auto CAD (*Not for end examination*).

Text Books:

1. K. L. Narayana & P. Kannaiah, Engineering Drawing, 3/e, Scitech Publishers
2. N. D. Bhatt, Engineering Drawing, 53/e, Charotar Publishers

Reference Books:

1. Engineering Drawing, K.L. Narayana and P. Kannaiah, Tata McGraw Hill, 2013.
2. Engineering Drawing, M.B. Shah and B.C. Rana, Pearson Education Inc, 2009.
3. Engineering Drawing with an Introduction to AutoCAD, Dhananjay Jolhe, Tata McGraw Hill, 2017.
- 4.

Course Title	COs	Programme Outcomes (POs) & Programme Specific Outcomes (PSOs)												
		PO1	PO2	PO3	PO4	PO5	PO6	PO7	PO8	PO9	PO10	PO11	PSO1	PSO2
Engineering Graphics	CO1	3		3							3		2	2
	CO2	2		2						3		2	2	
	CO3	2		2						3		2	2	
	CO4	3		3						3		2	2	
	CO5	3		3						3		2	2	

5. Correlation Matrix

CO	CO					Program Outcomes (PO)	PO(s): Action Verb and BTL (for PO1 to PO5)	Level of Correlation
	Lesson Plan (Hrs)	%	Correlation	Verb	BTL			
1	18	24	3	Apply	L3	PO1 PO2 PO10	Apply (L3) Develop (L3) Thumb Rule	3 3 3
2	15	20	2	Understand	L2	PO1 PO2 PO10	Apply (L3) Develop (L3) Thumb Rule	2 2 3
3	15	20	2	Analyze	L4	PO1 PO2 PO10	Apply (L3) Develop (L3) Thumb Rule	3 3 3
4	15	20	2	Analyze	L4	PO1 PO2 PO10	Apply (L3) Develop (L3) Thumb Rule	3 3 3
5	12	16	2	Apply	L3	PO1 PO2 PO10	Apply (L3) Develop (L3) Thumb Rule	3 3 3

Justification Statements:

CO1: Apply the concepts of engineering curves and scales for technical drawing.

Action Verb: Apply (L3)

PO1 Verb: **Apply (L3)**

CO1 Action verb is same level as PO1 verb. Therefore, the correlation is high (3) PO2 Verb: **Develop (L3)**

CO1 Action verb is same level as PO2 verb. Therefore, the correlation is high (3) PO10 Verb: Thumb Rule (TR)

CO1: Engineering graphics involves creating visual representations and technical drawings to communicate design ideas, concepts and specifications. Therefore, the correlation is high (3)

CO2: Understand the quadrant system to locate the position of points, lines and planes.

Action Verb: Understand (L2)

PO1 Verb: **Apply (L3)**

CO2: Action verb is less than PO1 verb by one level. Therefore, the

correlation is medium (2)PO2 Verb: **Develop (L3)**

CO2: Action verb is less than PO2 verb by one level. Therefore, the correlation is medium (2)

PO10 Verb: Thumb Rule (TR)

CO2: Engineering graphics involves creating visual representations and technical drawings to communicate design ideas, concepts and specifications. Therefore, the correlation is high (3)

CO3: Analyze the projection of solids located in quadrant system.

Action Verb: Analyze (L4)

PO1 Verb: **Apply (L3)**

CO3: Action verb is same level as PO1 verb. Therefore, the

correlation is high (3)PO2 Verb: **Develop (L3)**

CO3: Action verb is same level as PO2 verb. Therefore, the

correlation is high (3)PO10 Verb: Thumb Rule (TR)

CO3: Engineering graphics involves creating visual representations and technical drawings to communicate design ideas, concepts and specifications. Therefore, the correlation is high (3)

CO4: Analyze the sectional views and development of surfaces of regular solids

Action Verb: Analyze (L4)

PO1 Verb: **Apply (L3)**

CO4: Action verb is same level as PO1 verb. Therefore, the

correlation is high (3)PO2 Verb: **Develop (L3)**

CO4: Action verb is same level as PO2 verb. Therefore, the

correlation is high (3)PO10 Verb: Thumb Rule (TR)

CO4: Engineering graphics involves creating visual representations and technical drawings to communicate design ideas, concepts and specifications. Therefore, the correlation is high (3)

CO5: Apply orthographic and isometric projections concepts to construct the given object.

Action Verb: Apply (L3)

PO1 Verb: **Apply (L3)**

CO5: Action verb is same level as PO1 verb. Therefore, the

correlation is high (3)PO2 Verb: **Develop (L3)**

CO5: Action verb is same level as PO2 verb. Therefore, the

correlation is high (3)PO10 Verb: Thumb Rule (TR)

CO5: Engineering graphics involves creating visual representations and technical drawings to communicate design ideas, concepts and specifications. Therefore, the correlation is high (3)



Annamacharya Institute of Technology & Sciences, Tirupati
(Autonomous)

Engineering Graphics (23AES0301)

DEPARTMENT OF MECHANICAL ENGINEERING

**UNIT – I - LETTERING, DIMENSIONING AND
GEOMETRICAL CONSTRUCTION – 23AES0301**

LETTERING, DIMENSIONING AND GEOMETRICAL CONSTRUCTION

Engineering drawing is a two-dimensional representation of three-dimensional objects. In general, it provides necessary information about the shape, size, surface quality, material, manufacturing process, etc., of the object. It is the graphic language from which a trained person can visualize objects.

Methods of Expression

There are three methods of writing the graphic languages.

1. Freehand
2. With hand-held instruments
3. By computer

Methods of Shape Description

- a) Three Dimensional Drawings or Solid Geometrical drawings
- b) Two Dimensional Drawings or Plane Geometrical drawings.

Solid Geometrical drawings

Solid Geometrical drawing is the drawing which represents the objects of three dimensions.

Ex : Representing cone, sphere etc. on a drawing sheet.

Drawing Instruments and aids:

The Instruments and other aids used in drafting work are listed below:

- Drawing board
- Set squares
- French curves
- Templates
- Mini drafter
- Instrument box
- Protractor
- Set of scales
- Drawing sheets
- Pencils

Drawing Board:



Figure. 1.1

Until recently drawing boards used are made of well-seasoned softwood of about 25 mm thick with a working edge for T-square. Nowadays mini-drafters are used instead of T-squares which can be fixed on any board. The standard size of board depends on the size of drawing sheet size required.

Mini-Drafter

Mini-drafter consists of an angle formed by two arms with scales marked and rigidly hinged to each other. It combines the functions of T-square, set-squares, scales and protractor. It is used for drawing horizontal, vertical and inclined lines, parallel and perpendicular lines and for measuring lines and angles.



Figure. 1.2

Instrument Box

Instrument box contains 1. Compasses, 2. Dividers and 3. Inking pens.

What is important is the position of the pencil lead with respect to the tip of the compass. It should be at least 1 mm above as shown in the fig. because the tip goes into the board for grip by 1 mm.

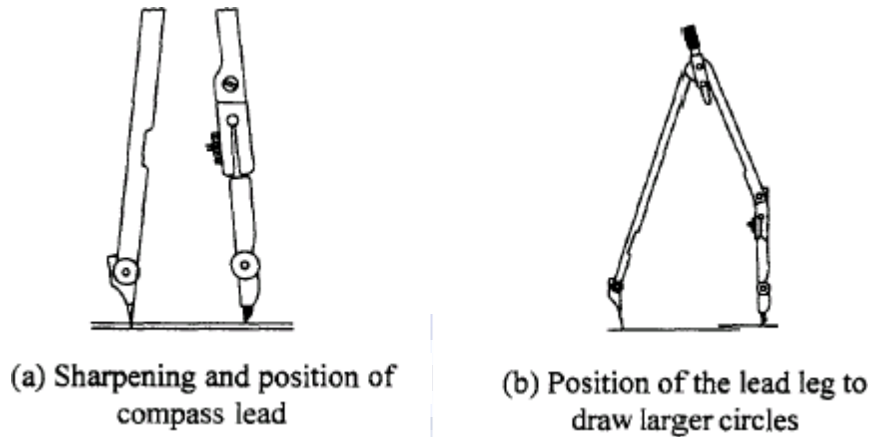

Figure. 1.3

Pencils

Pencils with leads of different degrees of hardness or grades are available in the market. The hardness or softness of the lead is indicated by 3H, 2H, H, HB, B, 2B, 3B, etc. The grade HB denotes medium hardness of lead used for general purpose. The hardness increases as the value of the numeral before the letter H increases. The lead becomes softer, as the value of the numeral before B increases.

- HB Soft grade for Border lines, lettering and free sketching
- H Medium grade for Visible outlines, visible edges and boundary lines
- 2H Hard grade for construction lines, Dimension lines, Leader lines, Extension lines,

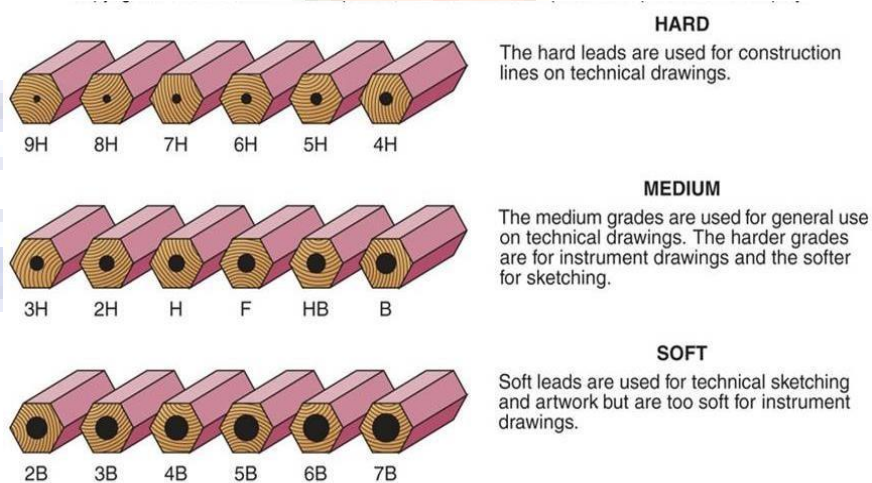

Figure. 1.4

Centre lines, Hatching lines and Hidden lines.

Drawing Sheet

The standard drawing sheet sizes are arrived at on the basic Principal of $x : y = 1 : 2^{(1/2)}$ and $xy = 1$ where x and y are the sides of the sheet. For example A0, having a surface area of 1 Sq.m; $x = 841$ mm and $y = 1189$ mm. The successive sizes are obtained by either by halving along the length or doubling the width, the area being in the ratio 1: 2. Designation of sizes is given in the fig. For class work use of A2 size drawing sheet is preferred.

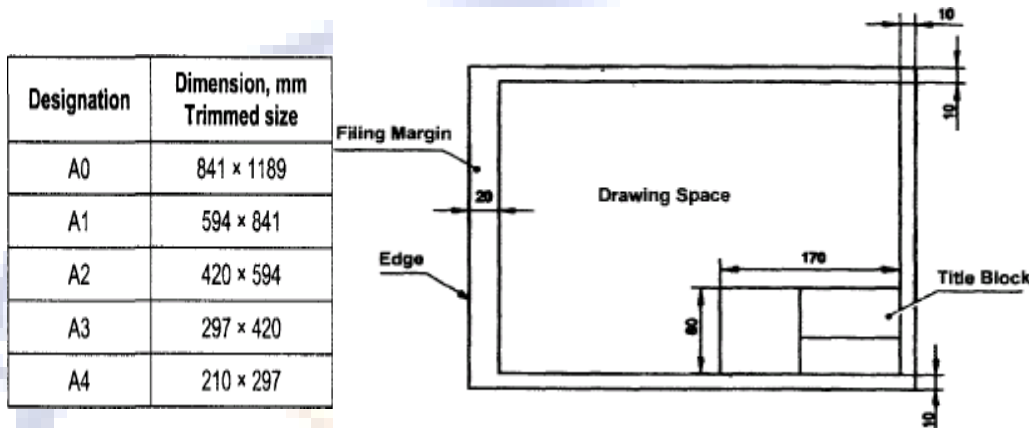

Figure. 1.5

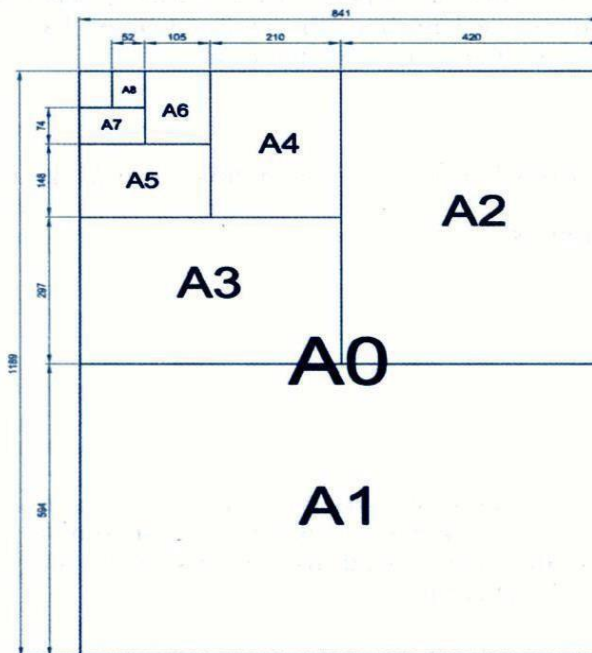

Figure. 1.6

Title Block

The title block should lie within the drawing space at the bottom right hand corner of the sheet. The title block can have a maximum length of 170 mm and width of 65mm providing the following information.

- Title of the drawing.

- Drawing number.
- Scale.
- Symbol denoting the method of projection.
- Name of the firm, and
- Initials of staff, who have designed, checked and approved.

Lines

Just as in English textbook the correct words are used for making correct sentences; in Engineering Graphics, the details of various objects are drawn by different types of lines. Each line has a definite meaning and sense to convey.

Type of line	Illustration	Application	Pencil Grade
Continuous thick		Visible outlines.	H
Continuous thin		Dimension lines, leader lines, extension lines, Construction lines & Hatching lines.	2H
Continuous thin wavy (drawn free hand)		Irregular boundary lines, short break lines.	2H

Figure. 1.7

Visible Outlines, Visible Edges: (Continuous wide lines) the lines drawn to represent the visible outlines/ visible edges / surface boundary lines of objects should be outstanding in appearance.

Dimension Lines (Continuous narrow Lines): Dimension Lines are drawn to mark dimension.

Extension Lines (Continuous narrow Lines): There are extended slightly beyond the respective dimension lines.

Construction Lines (Continuous narrow Lines): These are drawn for constructing drawings and should not be erased after completion of the drawing.

Hatching / Section Lines (Continuous Narrow Lines): These are drawn for the sectioned portion of an object. These are drawn inclined at an angle of 45° to the axis or to the main outline of the section.

Guide Lines (Continuous Narrow Lines): These are drawn for lettering and should not be

erased after lettering.

Break Lines (Continuous Narrow Freehand Lines): Wavy continuous narrow line drawn freehand is used to represent break of an object.

Break Lines (Continuous Narrow Lines with Zigzags): Straight continuous narrow line with zigzags is used to represent break of an object.

Dashed Narrow Lines (Dashed Narrow Lines): Hidden edges / Hidden outlines of objects are shown by dashed lines of short dashes of equal lengths of about 3 mm, spaced at equal distances of about 1 mm. the points of intersection of these lines with the outlines / another hidden line should be clearly shown.

Center Lines (Long-Dashed Dotted Narrow Lines): These are drawn at the center of the drawings symmetrical about an axis or both the axes. These are extended by a short distance beyond the outline of the drawing.

Cutting Plane Lines: Cutting Plane Line is drawn to show the location of a cutting plane. It is long-dashed dotted narrow line, made wide at the ends, bends and change of direction. The direction of viewing is shown by means of arrows resting on the cutting plane line.

Border Lines: Border Lines are continuous wide lines of minimum thickness 0.7 mm.





No.	Line description and Representation	Applications
01.1	Continuous narrow line B 	Dimension lines, Extension lines
		Leader lines, Reference lines
		Short centre lines
		Projection lines
		Hatching
		Construction lines, Guide lines
		Outlines of revolved sections Imaginary lines of intersection
01.1	Continuous narrow freehand line C 	Preferably manually represented termination of partial or interrupted views, cuts and sections, if the limit is not a line of symmetry or a center line ¹ .
01.1	Continuous narrow line with zigzags A 	Preferably mechanically represented termination of partial or interrupted views, cuts and sections, if the limit is not a line of symmetry or a center line ² .
01.2	Continuous wide line 	Visible edges, visible outlines
		Main representations in diagrams, maps, flow charts
02.1	Dashed narrow line D 	Hidden edges
		Hidden outlines
04.1	Long-dashed dotted narrow line E 	Center lines / Axes, Lines of symmetry
		Cutting planes (Line 04.2 at ends and changes of direction)
04.2	Long-dashed dotted wide line F 	Cutting planes at the ends and changes of direction outlines of visible parts situated in front of cutting plane

Figure. 1.8

CONVENTIONAL REPRESENTATION OF MATERIALS



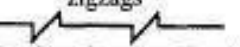

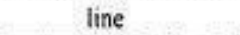
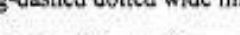
Type	Convention	Material
Metals		Steel, Cast Iron, Copper and its Alloys, Aluminium and its Alloys, etc.
		Lead, Zinc, Tin, White-metal, etc.
Glass		Glass
Packing and Insulating material		Porcelain, Stoneware, Marble, Slate, etc.
		Asbestos, Fibre, Felt, Synthetic resin products, Paper, Cork, Linoleum, Rubber, Leather, Wax, Insulating and Filling materials, etc.
Liquids		Water, Oil, Petrol, Kerosene, etc.
Wood		Wood, Plywood, etc.
Concrete		A mixture of Cement, Sand and Gravel

Figure. 1.9

LETTERING

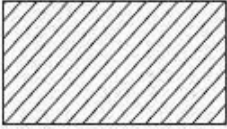
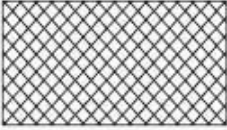
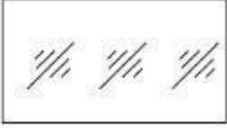
Lettering is defined as writing of titles, sub-titles, dimensions, etc., on a drawing.

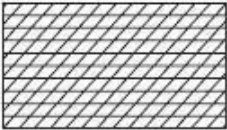
Importance of Lettering

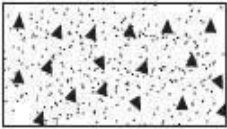
To undertake production work of an engineering component as per the drawing, the size and other details are indicated on the drawing. This is done in the form of notes and dimensions. Main Features of Lettering are legibility, uniformity and rapidity of execution. Use of drawing instruments for lettering consumes more time. Lettering should be done freehand with speed. Practice accompanied by continuous efforts would improve the lettering skill and style. Poor lettering mars the appearance of an otherwise good drawing.

Size of Letters

Size of Letters is measured by the height h of the CAPITAL letters as well as numerals. Standard heights for CAPITAL letters and numerals recommended by BIS are given below: 1.8, 2.5, 3.5, 5, 6, 10, 14 and 20 mm

Note: Size of the letters may be selected based upon the size of drawing.



(b) Gothic Letters (size: 10 mm)

VERTICAL (CAPITAL & lower case) LETTERS AND NUMERALS

Figure. 1.10

Guide Lines

In order to obtain correct and uniform height of letters and numerals, guide lines are drawn, using 2H pencil with light pressure. HB grade conical end pencil is used for lettering.

The following are some of the guide lines for lettering

- Drawing numbers, title block and letters denoting cutting planes, sections are written in 10 mm size.
- Drawing title is written in 7 mm size.
- Hatching, sub-titles, materials, dimensions, notes, etc., are written in 3.5 mm size.
- Space between lines = $3/4 h$
- Space between words may be equal to the width of alphabet M or $3/5 h$.

Procedure for Lettering

Thin horizontal guide lines are drawn first at a distance 'h' apart.

Lettering Technique: Horizontal lines of the letters are drawn from left to right. Vertical, Inclined and curved lines are drawn from top to bottom.

After lettering has been completed, the guidelines are not erased.

Specifications	Value	Size							
Capital Letter Height	h	2.5	3.5	5	7	10	14	20	
Lowercase Letter Height	$a = (5/7) h$	-	2.5	3.5	5	7	10	14	
Thickness of Lines	$b = (1/14) h$	0.18	0.25	0.35	0.5	0.7	1	1.4	
Spacing between Characters	$c = (1/7) h$	0.35	0.5	0.7	1	1.4	2	2.8	
Min. Spacing between words	$d = (3/7) h$	1.05	1.5	2.1	3	4.2	6	8.4	
Min. Spacing between Base Lines	$e = (10/7) h$	3.5	5	7	10	14	20	28	

Figure. 1.11

Recommended Size (height h) of Letters / Numerals	
Main Title	5 mm, 7 mm, 10 mm
Sub-Titles	3.5 mm, 5 mm
Dimensions, Notes, etc.	2.5 mm, 3.5 mm, 5 mm

Figure. 1.12

Dimensioning

Drawing of a component, in addition to providing complete shape description, must also furnish Information regarding the size description. These are provided through the distances between the Surfaces, location of holes, nature of surface finish, type of material, etc. The expression of these Features on a drawing, using lines, symbols, figures and notes is called

dimensioning.

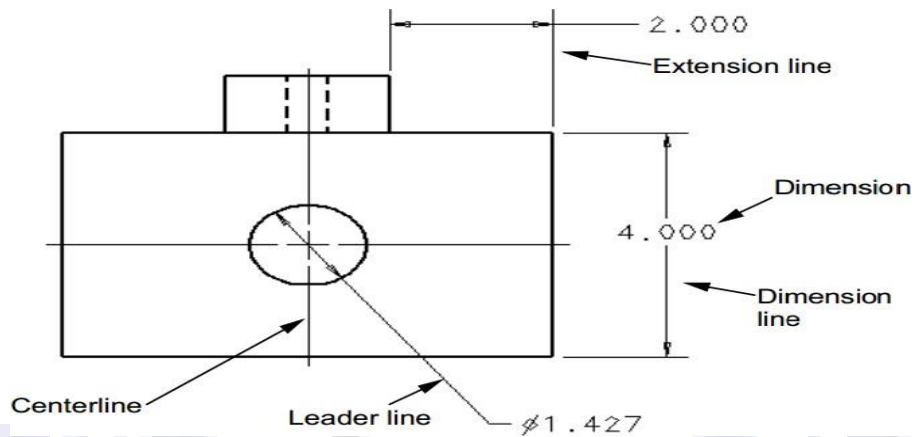

Figure. 1.13

Methods of Indicating Dimensions

The dimensions are indicated on the drawings according to one of the following two methods.

Method - 1 (Aligned method)

Dimensions should be placed parallel to and above their dimension lines and preferably at the middle, and clear of the line. Dimensions may be written so that they can be read from the bottom or from the right side of the drawing. Dimensions on oblique dimension lines should be oriented as shown in Fig.2.26a and except where unavoidable, they shall not be placed in the 30° zone. Angular dimensions are oriented.

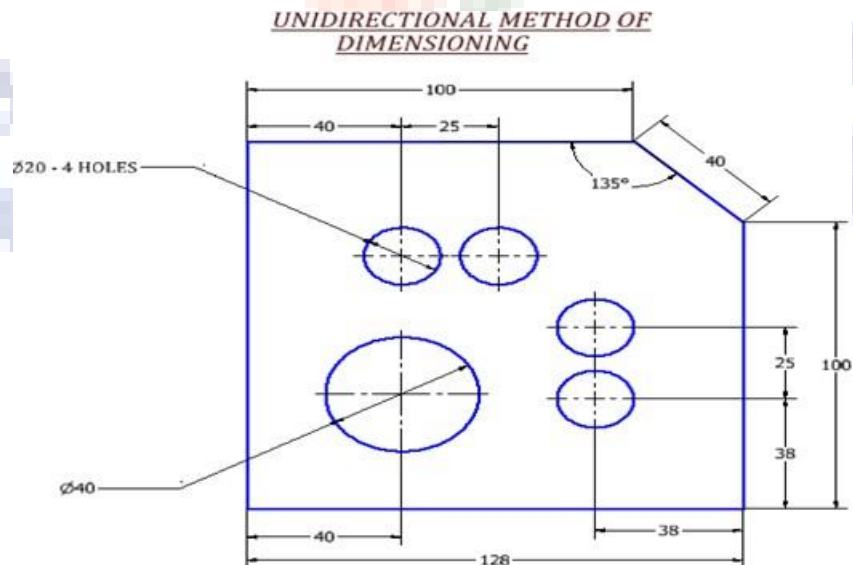

Figure. 1.14

Method - 2 (Uni-directional)

Dimensions should be indicated so that they can be read from the bottom of the drawing only. Non- horizontal dimension lines are interrupted, preferably in the middle for insertion of the dimension.

Note: Horizontal dimensional lines are not broken to place the dimension in both cases.

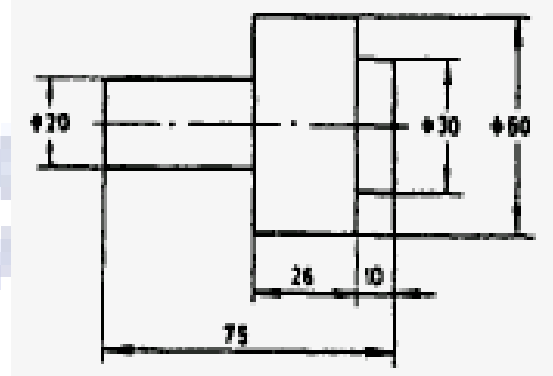

Figure. 1.15

Arrow heads

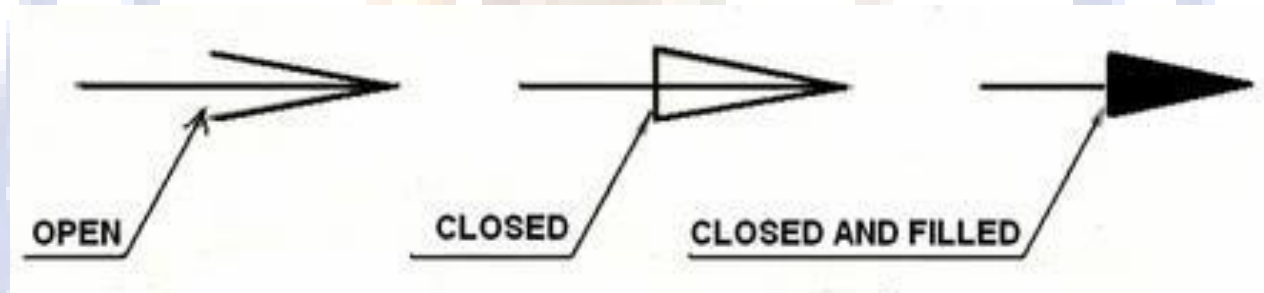

Figure. 1.16

GEOMETRICAL CONSTRUCTIONS

Introduction

Engineering drawing consists of a number of geometrical constructions. A few methods are illustrated here without mathematical proofs.

a) To divide a straight line into a given number of equal parts say 5.

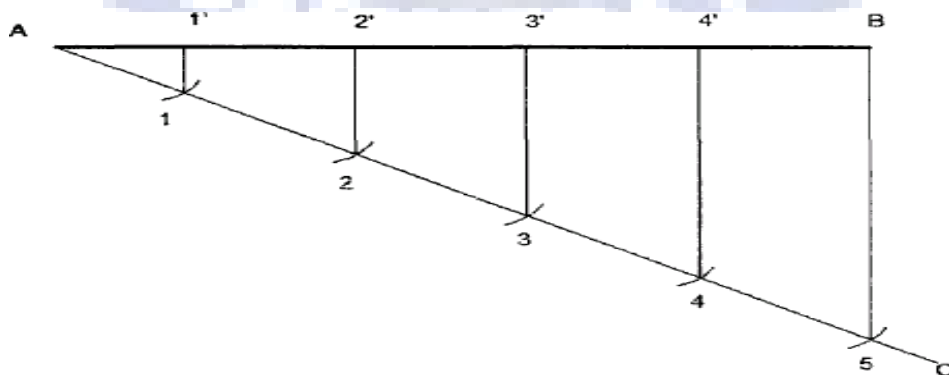

Figure. 1.17

Construction

- Draw AC at any angle θ to AB
- Construct the required number of equal parts of convenient length on AC like 1, 2 and 3
- Join the last point 5 to B
- Through 4, 3, 2, 1 draw lines parallel to 5B to intersect AB at 4', 3', 2' and 1'.

b) To bisect a given angle.

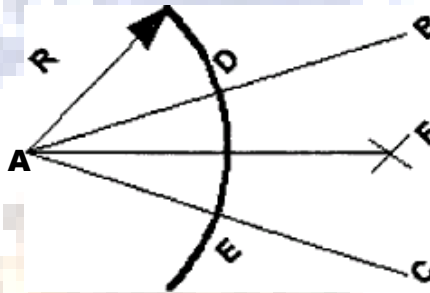

Figure. 1.18

Construction

- Draw a line AB and AC making the given angle.
- With center A and any convenient radius R draw an arc intersecting the sides at D and E.
- With center's D and E and radius larger than half the chord length DE, draw arcs intersecting at F
- Join AF, $\angle BAF = \angle FAC$.

To inscribe a regular polygon of any number of sides in a given circle.

Construction

- Draw the given circle with AB as diameter.
- Divide the diameter AB into N equal parts say 5.
- With AB as radius and A & B as centers, draw arcs intersecting each other at C.
- Join C-P and extend to intersect the circle at D.
- Join A-D which is the length of the side of the required polygon.
- Set the compass to the length AD and starting from D mark off on the circumference of the circles, obtaining the points E, F, etc. The figure obtained by joining the points A, D, E etc., is the required polygon.

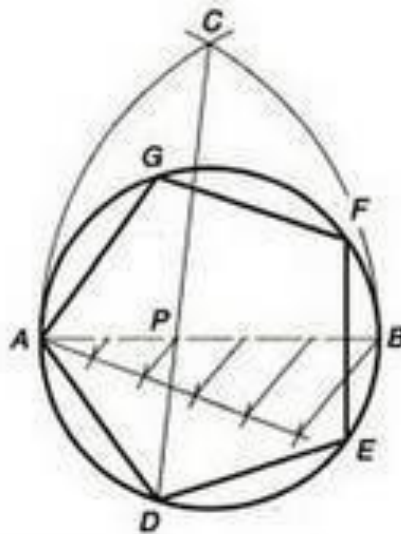

Figure. 1.19

To inscribe a hexagon in a given circle.

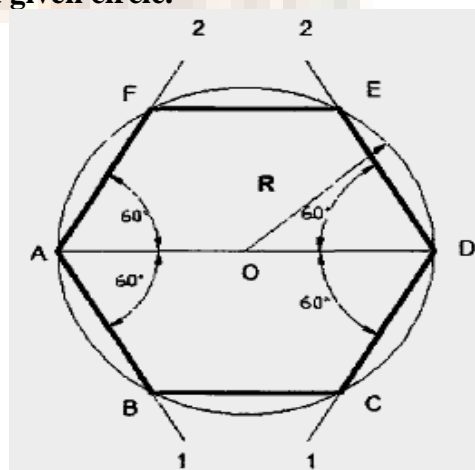

Figure. 1.20

Construction

- With center O and radius R draw the given circle.
- Draw any diameter AD to the circle.
- Using $30^\circ - 60^\circ$ set-square and through the point A draw lines A1, A2 at an angle 60° with AD, intersecting the circle at B and F respectively.
- Using $30^\circ - 60^\circ$ set-square and through the point D draw lines D1, D2 at an angle 60° with DA, intersecting the circle at C and E respectively.
- By joining A, B, C, D, E, F and A, S the required hexagon is obtained.

To construct a regular polygon (say a pentagon) given the length of the side.

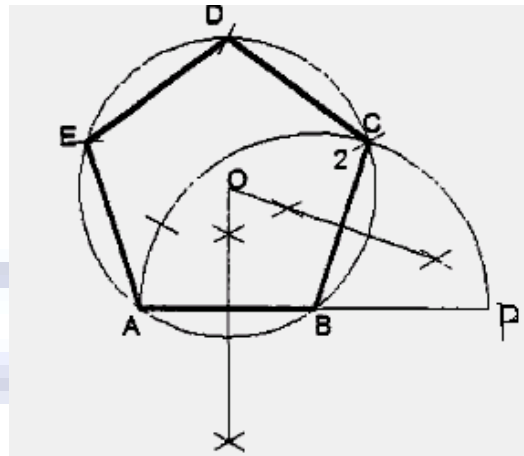

Figure. 1.21

Construction

- Draw a line AB equal to the side and extend to P such that $AB = BP$
- Draw a semicircle on AP and divide it into 5 equal parts by trial and error.
- Join B to second division Irrespective of the number of sides of the polygon B is always joined to the second division.
- Draw the perpendicular bisectors of AB and B2 to intersect at O.
- Draw a circle with O as center and OB as radius.
- With AB as radius intersect the circle successively at D and E. Then join CD, DE and EA.

To construct a regular polygon (say a hexagon) given the side AB.

Construction

- Draw a line AB equal to the side and extend to P such that $AB = BP$
- Draw a semicircle on AP and divide it into 6 equal parts by trial and error.
- Join B to second division
- Join B- 3, B-4, and B-5 and produce them.
- With 2 as center and radius AB intersect the line B, 3 produced at D. Similarly get the point E and F.
- Join 2- D, D-E, E-F and F-A to get the required hexagon.

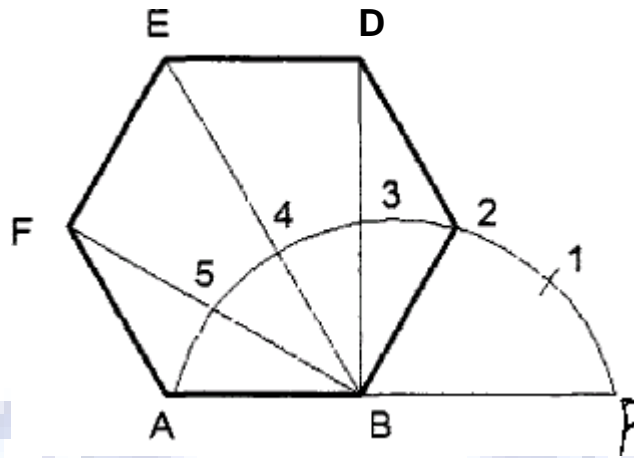

Figure. 1.22

To construct a regular figure of given side length and of N sides on a straight line.

Construction

- Draw the given straight line AB.
- At B erect a perpendicular BC equal in length to AB.
- Join AC and where it cuts the perpendicular bisector of AB, number the point 4.
- Complete the square ABCD of which AC is the diagonal.
- With radius AB and center B describe arc AC as shown.
- Where this arc cuts the vertical center line numbers the point 6.
- This is the center of a circle inside which a hexagon of side AB can now be drawn.
- Bisect the distance 4-6 on the vertical centre line.
- Mark this bisection 5.
- This is the center in which a regular pentagon of side AB can now be drawn.
- On the vertical centre line step off from point 6 a distance equal in length to the distance
- 5-6.
- This is the center of a circle in which a regular heptagon of side AB can now be drawn.
- If further distances 5-6 are now stepped off along the vertical centre line and are numbered consecutively, each will be the centre of a circle in which a regular polygon can be inscribed with side of length AB and with a number of sides denoted by the number against the centre.

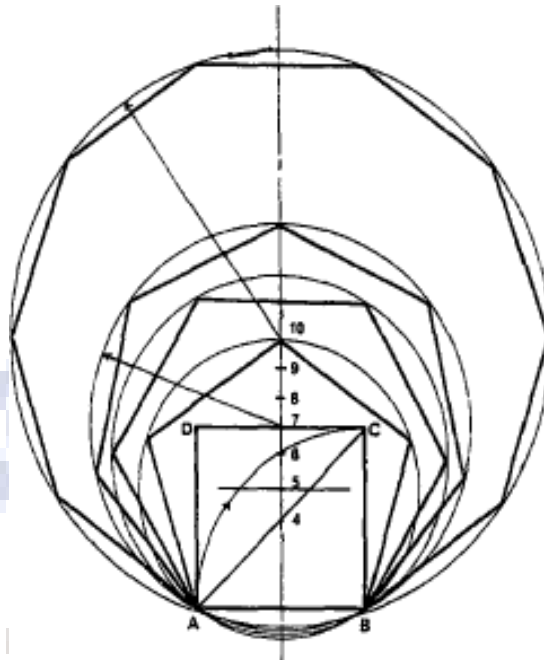

Figure. 1.23

CONIC SECTIONS

Cone is formed when a right angled triangle with an apex and angle θ is rotated about its altitude as the axis. The length or height of the cone is equal to the altitude of the triangle and the radius of the base of the cone is equal to the base of the triangle. The apex angle of the cone is 2θ . When a cone is cut by a plane, the curve formed along the section is known as a conic.

CIRCLE

When a cone is cut by a section plane A-A making an angle $\alpha = 90^\circ$ with the axis, the section obtained is a circle.

ELLIPSE

When a cone is cut by a section plane B-B at an angle, α more than half of the apex angle i.e., θ and less than 90° , the curve of the section is an ellipse. Its size depends on the angle α and the distance of the section plane from the apex of the cone.

PARABOLA

If the angle α is equal to θ i.e., when the section plane C-C is parallel to the slant side of the cone the curve at the section is a parabola. This is not a closed figure like circle or ellipse. The size of the parabola depends upon the distance of the section plane from the slant side of the cone.

HYPERBOLA

If the angle α is less than θ (section plane D-D), the curve at the section is hyperbola. The curve of intersection is hyperbola, even if $\alpha = \theta$, provided the section plane is not passing through the apex of the cone. However if the section plane passes through the apex, the section produced is an isosceles triangle.

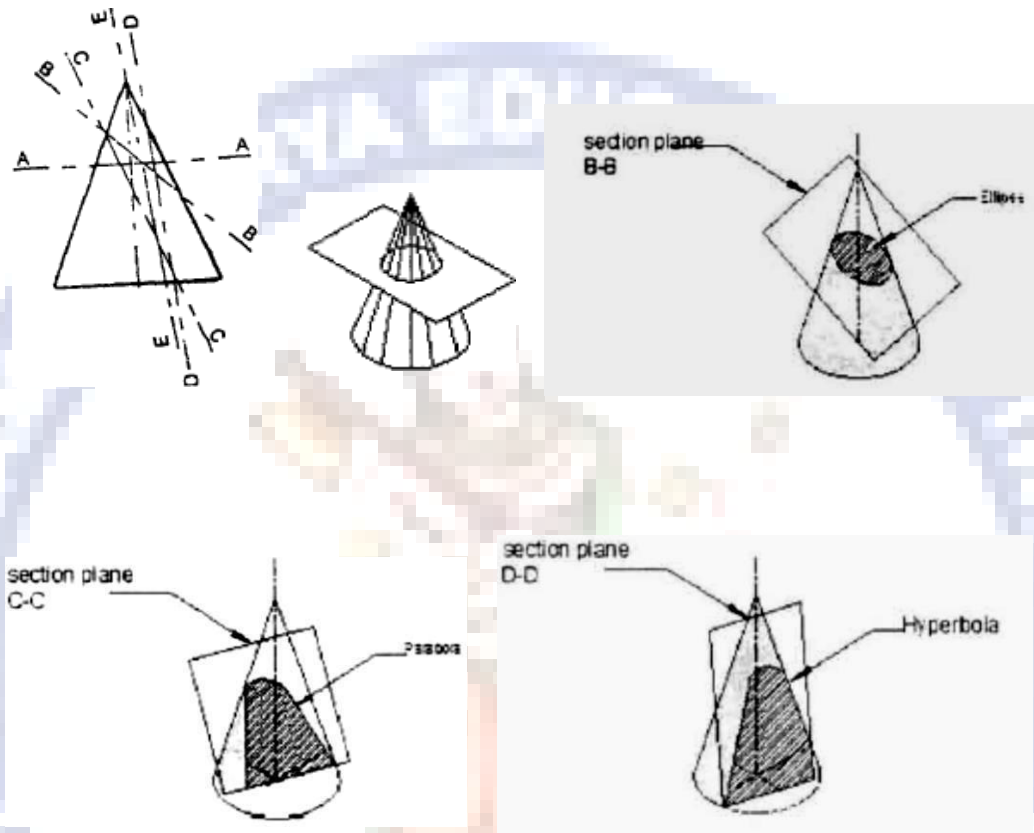

Figure. 1.24

Eccentricity (e):

If $e=1$, it is parabola

If $e>1$, it is hyperbola

If $e<1$, it is an ellipse

Where eccentricity e is the ratio of distance of the point from the focus to the distance of the point from the directrix.

PARABOLA

In physical world, parabola are found in the main cables on simple suspension bridge, as parabolic reflectors in satellite dish antennas, vertical curves in roads, trajectory of a body, automobile head light, parabolic receivers.

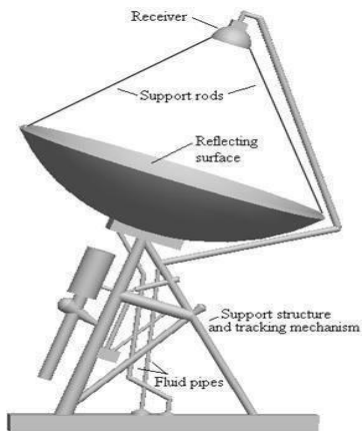

Figure. 1.25



Figure. 1.26

To draw a parabola with the distance of the focus from the directrix at 50mm (Eccentricity method)

Construction

- Draw the axis AB and the directrix CD at right angles to it:
- Mark the focus F on the axis at 50mm.
- Locate the vertex V on AB such that $AV = VF$
- Draw a line VE perpendicular to AB such that $VE = VF$
- Join A, E and extend. Now, $VE/VA = VF/VA = 1$, the eccentricity.
- Locate number of points 1, 2, 3, etc., to the right of V on the axis, which need not be equidistant.
- Through the points 1, 2, 3, etc., draw lines perpendicular to the axis and to meet the line AE extended at 1', 2', 3' etc.
- With centre F and radius 1-1', draw arcs intersecting the line through 1 at P1 and P`1

- Similarly, locate the points P2, P'2, P3, P'3 etc., on either side of the axis. Join the points by smooth curve, forming the required parabola.

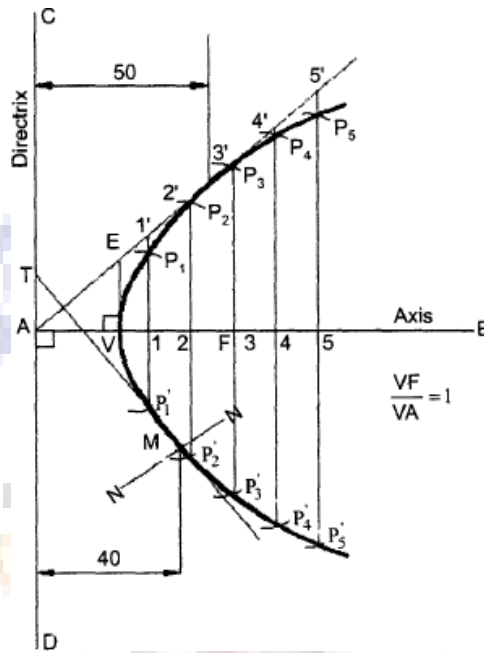

Figure. 1.27

- To draw a normal and tangent through a point 40mm from the directrix.
- To draw a tangent and normal to the parabola. Locate the point M which is at 40 mm from the directrix. Then join M to F and draw a line through F, perpendicular to MF to meet the directrix at T. The line joining T and M and extended is the tangent and a line NN, through M and perpendicular to TM is the normal to the curve.

ELLIPSE

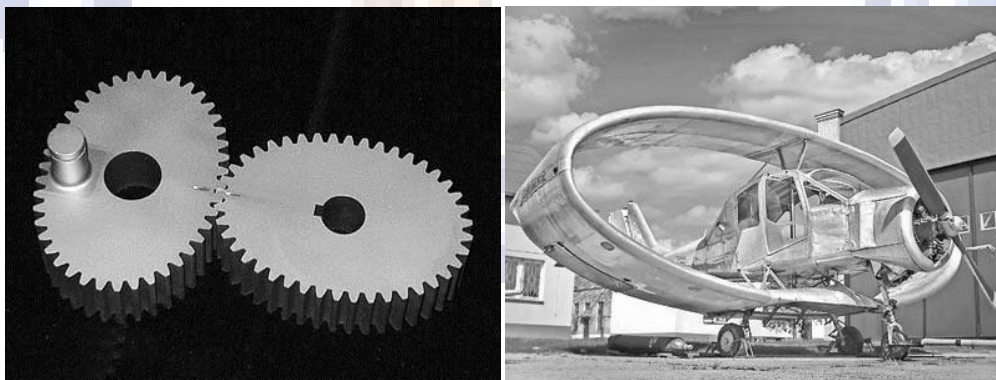

Figure. 1.28

Ellipses are mostly found as harmonic oscillators, phase visualization, elliptical gears, and ellipse wings.

To draw an ellipse with the distance of the focus from the directrix at 50mm and eccentricity = 2/3 (Eccentricity method)

Construction

- Draw any vertical line CD as directrix.
- At any point A in it, draw the axis.
- Mark a focus F on the axis such that AF=50mm.
- Divide AF in to 5 equal divisions.
- Mark the vertex V on the third division-point from A.
- Thus eccentricity $e = VF/VA = 2/3$.
- A scale may now be constructed on the axis which will directly give the distances in the required ratio.
- At V, draw a perpendicular VE = VF. Draw a line joining A and E.
- Mark any point 1 on the axis and through it draw a perpendicular to meet AE produced at 1'.
- With centre F and radius equal to 1-1', draw arcs to intersect a perpendicular through 1 at points P1 and P'1.
- Similarly mark points 2, 3 etc. on the axis and obtain points P2 and P'2, P3 and P'3, etc.
- Draw the ellipse through these points, it is a closed curve two foci and two directrices.

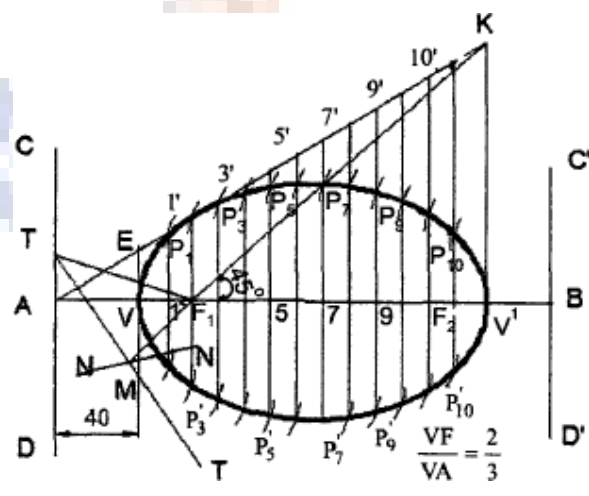

Figure. 1.29

HYPERBOLA

Lampshades, gear transmission, cooling towers of nuclear reactors are some of the applications of Hyperbola.



Figure. 1.30

To draw a hyperbola with the distance of the focus from the directrix at 50mm and $e=3/2$ (Eccentricity method)

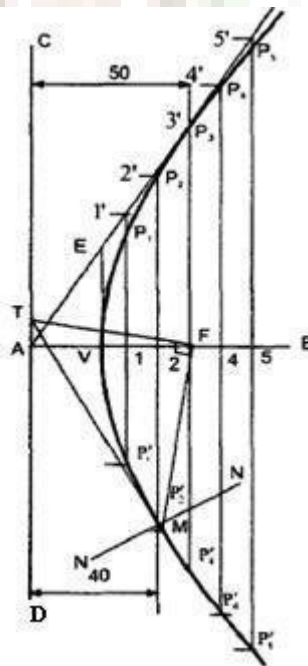

Figure.
1.31

Construction

- Draw the directrix CD and the axis AB.

- Mark the focus F on AB and 65mm from A.
- Divide AF into 5 equal divisions and mark V the vertex, on the second division from A.
- Draw a line VE perpendicular to AB such that $VE=VF$. Join A and E.
- Mark any point 1 on the axis and through it, draw a perpendicular to meet AE produced at 1'.
- With center F and radius equal to 1-1', draw arcs intersecting the perpendicular through 1 at P1 and P'1.
- Similarly mark a number of points 2, 3 etc. and obtain points P2 and P'2, etc.

Important questions:

- Construct a regular pentagon of 25 mm side, by two different methods.
- Draw an ellipse when the distance of its vertex from its directrix is 24mm and distance of its focus from directrix is 42mm.
- Draw the locus of a point which moves in such a manner that its distance from a fixed point is equal to its distance from a fixed straight line. Consider the distance between the fixed point and the fixed line as 60mm. Name the curve.
- Construct a parabola if the distance between its focus and directrix is 60 mm. Also draw a tangent to the curve.
- A vertex of a hyperbola is 50 mm from its focus. Draw two parts of the hyperbola; if the eccentricity is $\frac{3}{2}$.
- The focus of a hyperbola is 60mm from its directrix. Draw the curve when eccentricity is $\frac{5}{3}$. Draw a tangent and a normal to the curve at a point distant 45mm from the directrix.
- Draw a parabola when the distance between focus and directrix is 50mm. Draw a tangent and normal at a point distant 70mm from the directrix.
- The vertex of a hyperbola is 5cms from directrix. Draw the curve if the eccentricity is $\frac{3}{2}$. Draw the normal and tangent at a point 50mm from axis.



UNIT – II - ORTHOGRAPHIC PROJECTION

Introduction

PROJECTION OF POINTS AND STRAIGHT LINES

What is point?

An element which has no dimensions, it can be situated in the following positions with respect to principal planes of the projections. To Draw Projections of any object, one Must have Following Information

- A) **OBJECT** {With It's Description, Well Defined.}
- B) **OBSERVER** {Always observing Perpendicular to Resp. Ref. Plane}.
- C) **LOCATION OF OBJECT**, {Means It's Position with Reference to H.P. & V.P.}

Position of the Points

- Point situated above H.P and in front of V.P.
- Point situated above H.P and behind V.P
- Point situated below H.P and behind V.P.
- Point situated below H.P and in front of V.P.
- Point situated on H.P and in front of V.P.
- Point situated above H.P and on V.P.
- Point situated on H.P and behind V.P.
- Point situated below H.P and on V.P.
- Point situated on both H.P and V.P.

Conventional Representation:

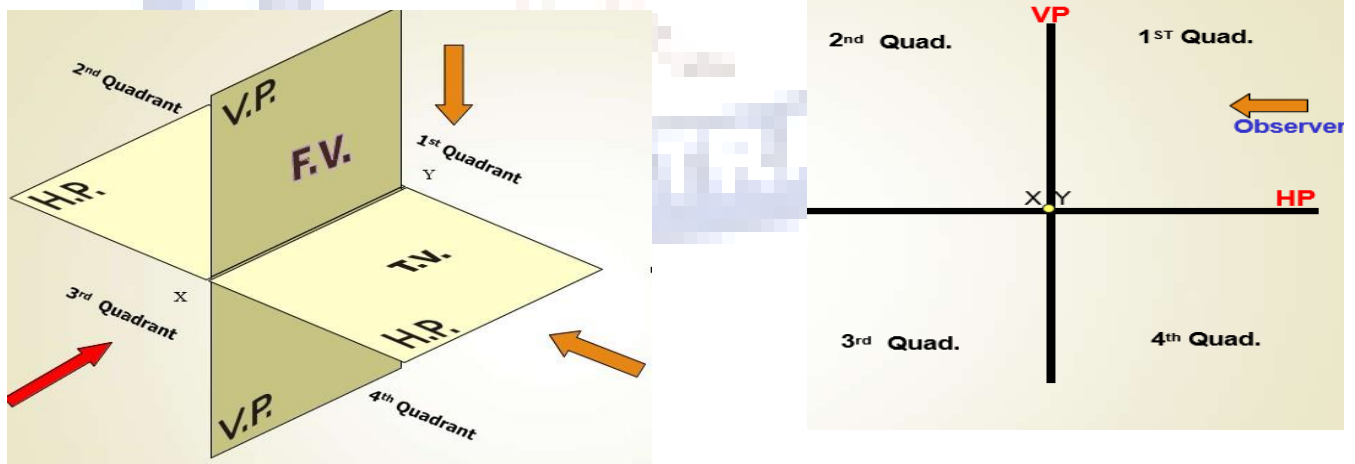

Figure 2.1

- Actual Position of a point designated by capitals i.e. A, B, C, D ...
- Front view of a point is designated by small letters with dashes i.e. a', b', c', d'....
- Top view of a point is designated by only small letters i.e. a, b, c, d
- Side view of a point is designated by small letters with double dashes i.e. a'', b'', c'', d''...
- The Intersection of reference planes is a line known as reference line denoted by x-y and the line connecting the front and top view is known as projection line; it is always perpendicular to the principal axis (x-y line).

Problem:

Draw the orthographic projections of the following points?

- (a.) Point P is 30 mm. above H.P and 40 mm. in front of VP (b.) Point Q is 25 mm. above H.P and 35 mm. behind VP (c.) Point R is 32 mm. below H.P and 45 mm behind VP (d.) Point S is 35 mm. below H.P and 42 mm in front of VP (e.) Point T is in H.P and 30 mm behind VP (f.) Point U is in V.P and 40 mm. below HP (g.) Point V is in V.P and 35 mm. above H.P (h.) Point W is in H.P and 48 mm. in front of VP

Solution:

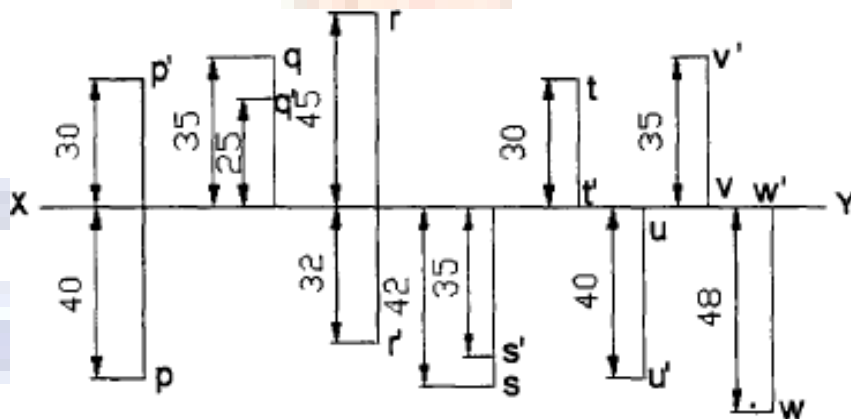

Figure 2.2

PROJECTION OF STAIGHT LINES

Introduction

What is Line?

A Shortest distance between two points and the actual length of the line is known as True Length denoted by TL.

Orientation of Straight Lines

- Line parallel to both H.P and V.P
- Line perpendicular to H.P and parallel to V.P
- Line perpendicular to V.P and parallel to H.P
- Line inclined to H.P and parallel to V.P
- Line inclined to V.P and parallel to H.P
- Line situated in H.P
- Line situated in V.P
- Line situated in both H.P and V.P
- Line inclined to both the reference planes.
- Line inclined to both H.P and V.P front view angle and top view angle = 90 deg
- Line inclined to both H.P and V.P front view angle and top view angle = 90 deg

Problems

Line parallel to both H.P and V.P

A 50mm long line AB is parallel to both H.P and V.P. The line is 25mm in front of V.P and 60mm above H.P, draw the projections of the line.

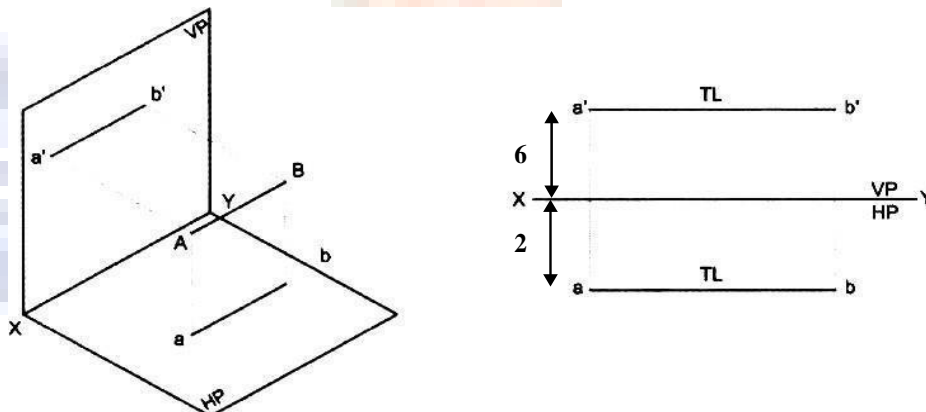

Figure 2.3

Line perpendicular to H.P

1.

A 60mm long line AB has its end A at a distance of 20mm above the H.P. The line is perpendicular to the H.P and 40mm in front of V.P, draw the projections of the line.

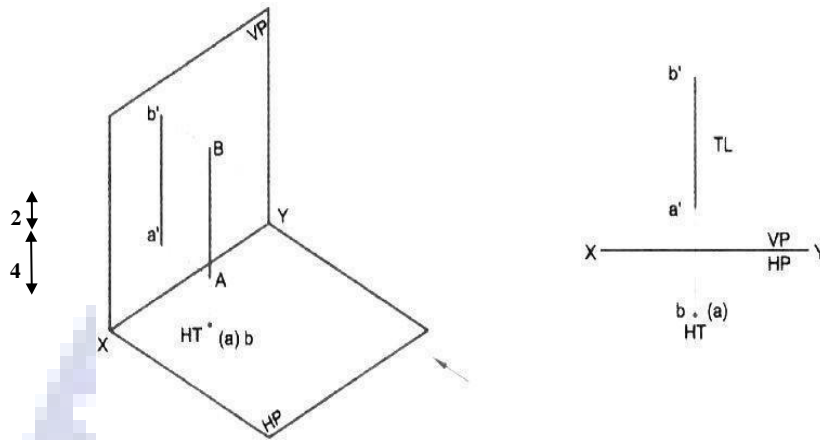

Figure 2.4

Line perpendicular to V.P

A 60mm long line AB, has its end A at a distance of 20mm in front of the V.P. the line is perpendicular to V.P and 40mm above H.P, draw the projection of the line.

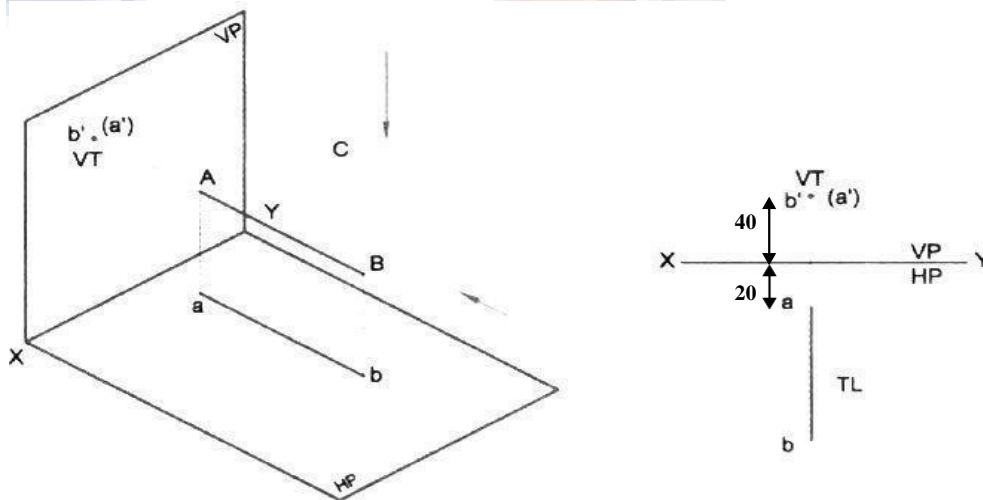

Figure 2.5

Line inclined to H.P and parallel to V.P

A 80mm long line AB has the end A at a distance of 20mm above HP and 40mm in front of V.P. The line is inclined at 30 deg to H.P and parallel to V.P, draw the projection of the line.

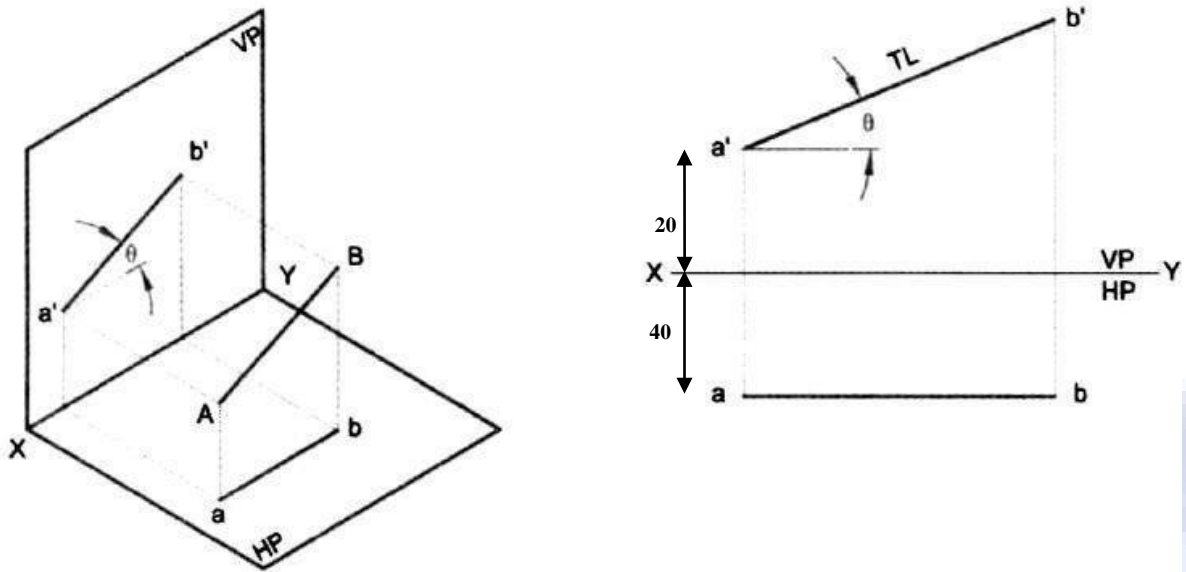

Figure 2.6

Line inclined to V.P and parallel to H.P

An 80mm long line AB is inclined at 30 deg to V.P and is parallel to H.P. The end A is 20mm above the H.P and 20mm in front of the V.P, draw the projection of the line.

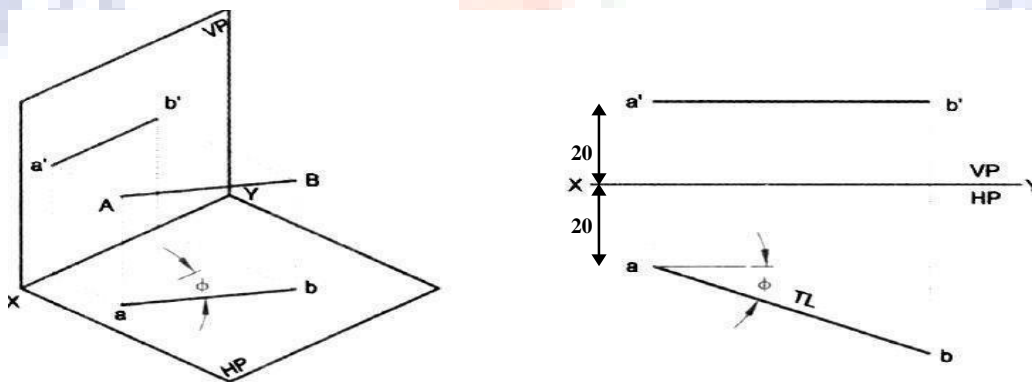

Figure 2.7

Line situated in H.P

A line AB 60mm long is situated in H.P and inclined to V.P at 30 deg. The end A is 20mm in

front of V.P, draw the projection of line.

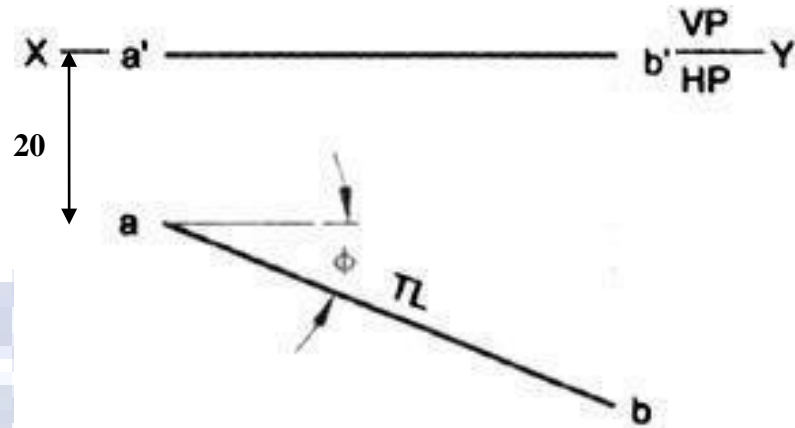

Figure 2.8

Line situated in V.P

Draw the projections of 70mm long line AB situated in the V.P and inclined at 30 deg to H.P. The end A is 25 mm above H.P.

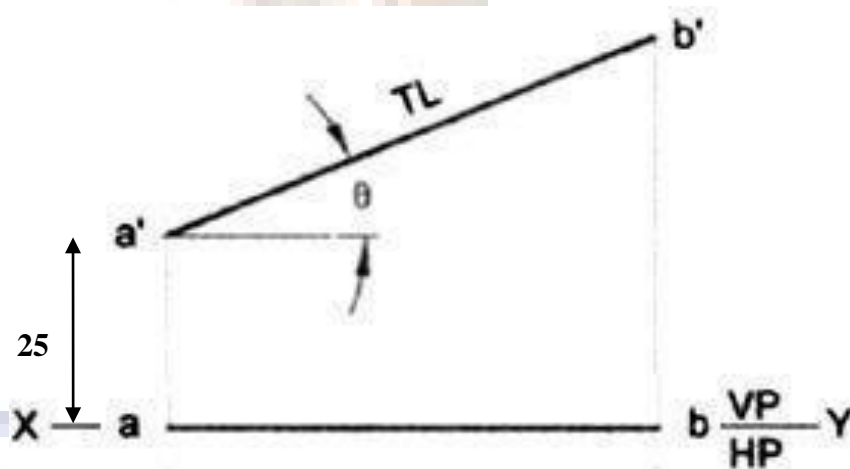

Figure 2.9

Lines inclined to both the reference planes.

A 70mm long line AB has an end A at 20mm above H.P and 30mm in front of V.P. The line is inclined at 45 deg to the H.P and 30 deg to V.P, draw the projections.

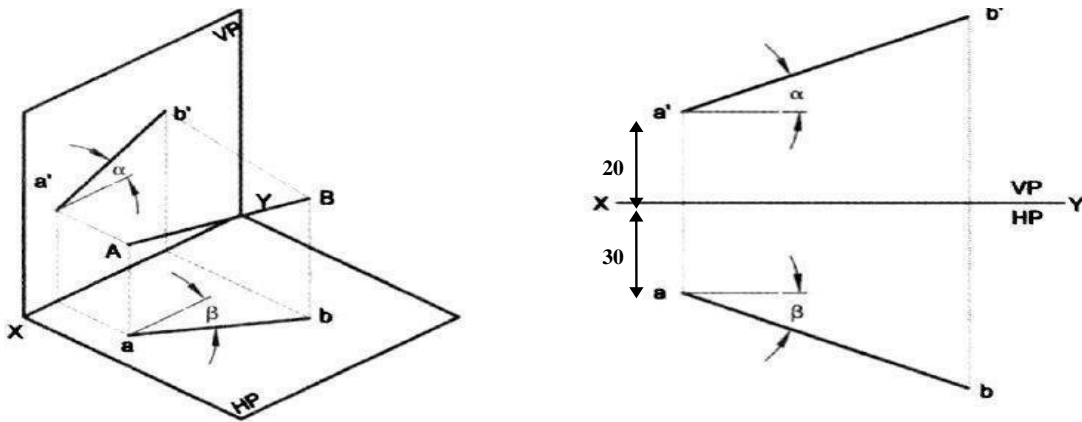

Figure 2.10

A line AB, 70mm long, has its end A 15mm above HP and 20mm in front of VP. It is inclined at 30° to HP and 45° to VP. Draw its projections and mark its traces

Solution:

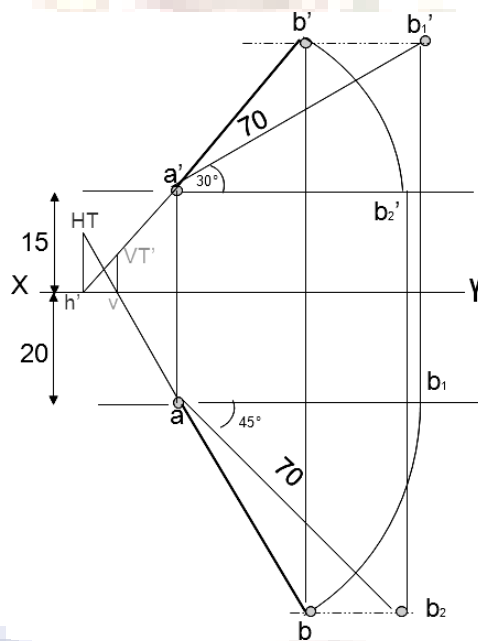

Figure 2.11

The top view of a 75mm long line AB measures 65mm, while its front view measures 50mm. Its one end A is in HP and 12mm in front of VP. Draw the projections of AB and determine its inclination with HP and VP

Solution:

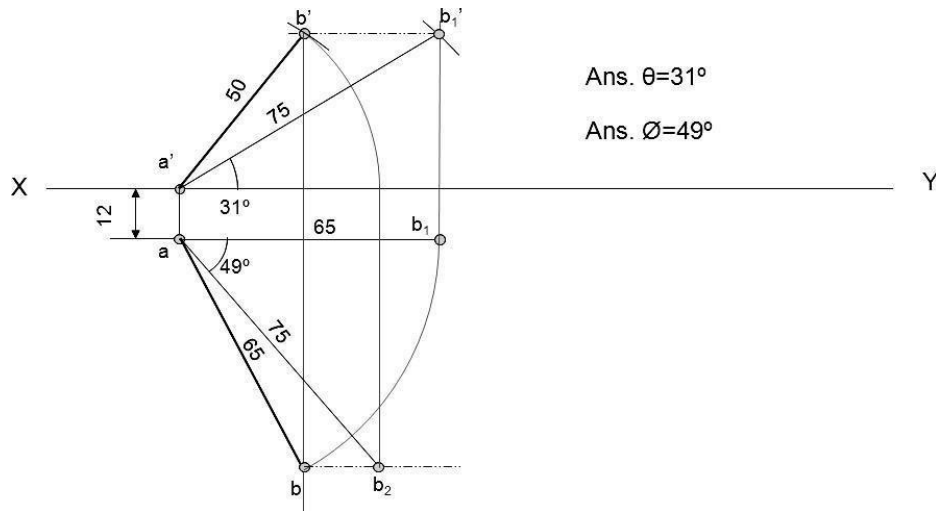

Figure 2.12

A line AB, 65mm long has its end A 20mm above H.P. and 25mm in front of V.P. The end B is 40mm above H.P. and 65mm in front of V.P. Draw the projections of AB and shows its inclination with H.P.

Solution:

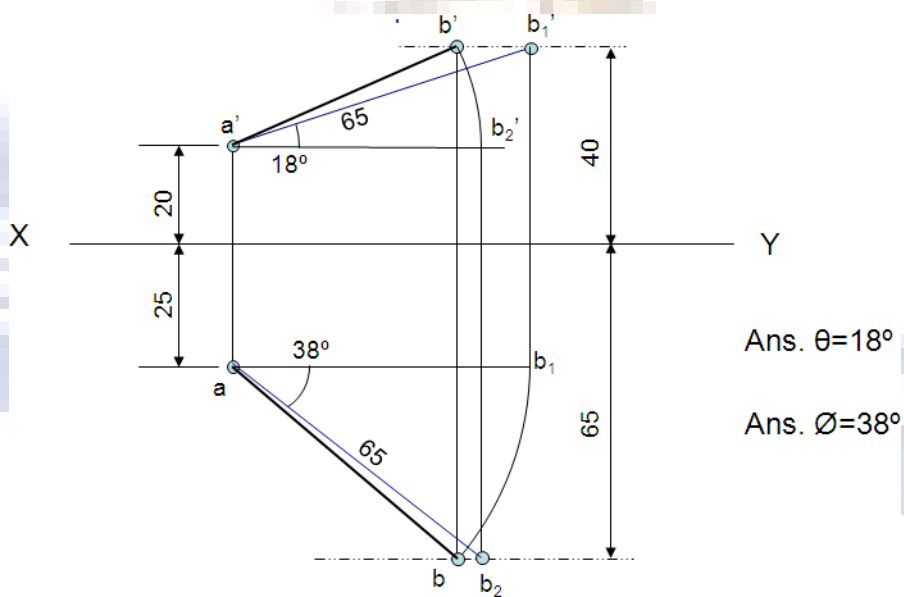

Figure 2.13

A line AB, 90mm long, is inclined at 45° to the H.P. and its top view makes an angle of 60° with the V.P. The end A is in the H.P. and 12mm in front of V.P. Draw its front view and finds its true inclination with the V.P.

Solution:

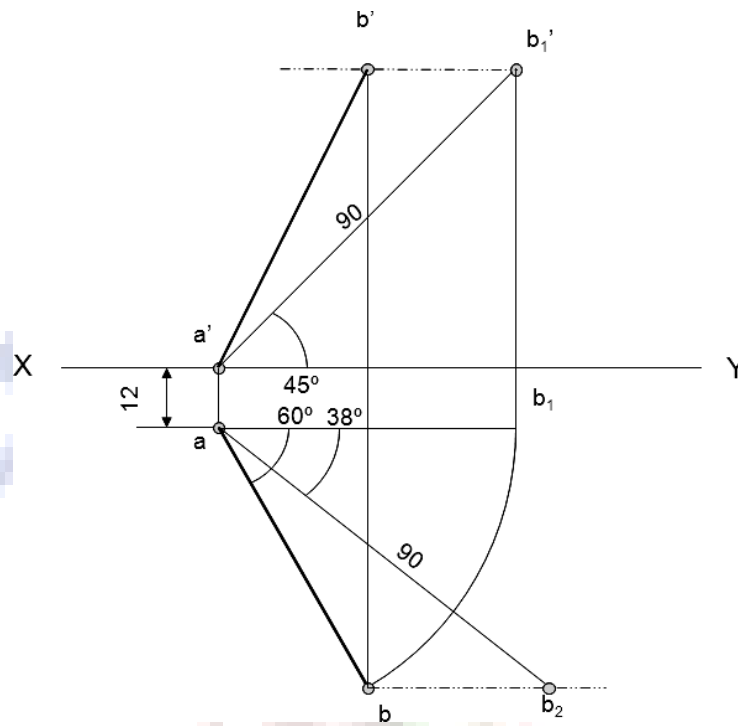
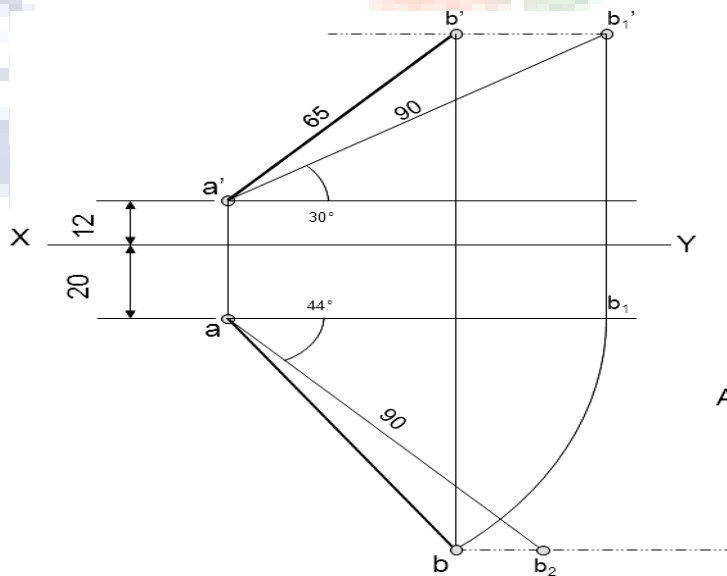

Figure 2.14

A line AB, 90mm long, is inclined at 30 to the HP. Its end A is 12mm above the HP and 20mm in front of the VP. Its FV measures 65mm. Draw the TV of AB and determine its inclination with the VP.

Solution:



Ans: $\theta = 44^\circ$

Figure 2.15

Problem: A line AB, inclined at 40° to the V.P. has its end 50mm and 20mm above the H.P. the length of its front view is 65mm and its V.T. is 10mm above the H.P. determine the true length of AB its inclination with the H.P. and its H.T.

Solution:

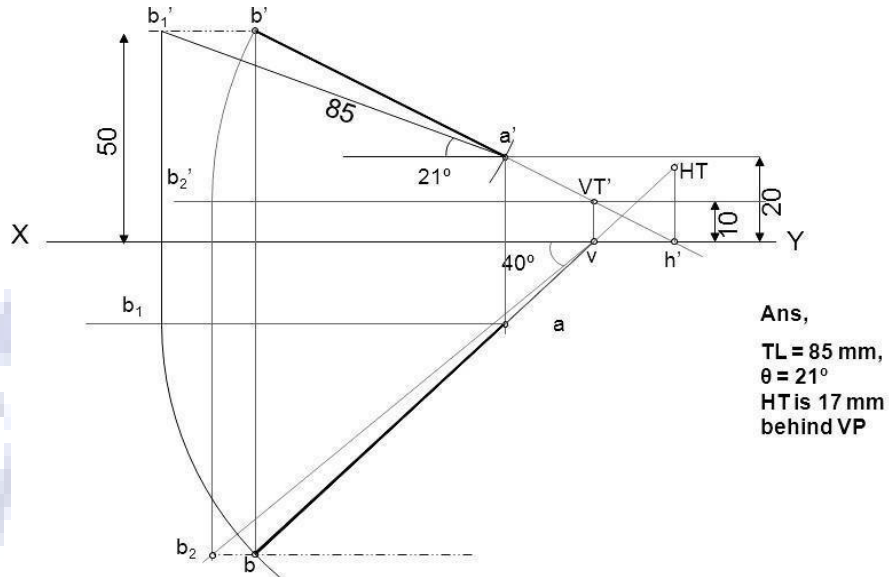

Ans,
 TL = 85 mm,
 $\theta = 21^\circ$ &
 HT is 17 mm
 behind VP

Figure 2.16

The top view of a 75mm long line CD measures 50 mm. C is 50 mm in front of the VP & 15mm below the HP. D is 15 mm in front of the VP & is above the HP. Draw the FV of CD & find its inclinations with the HP and the VP. Show also its traces.

Solution:

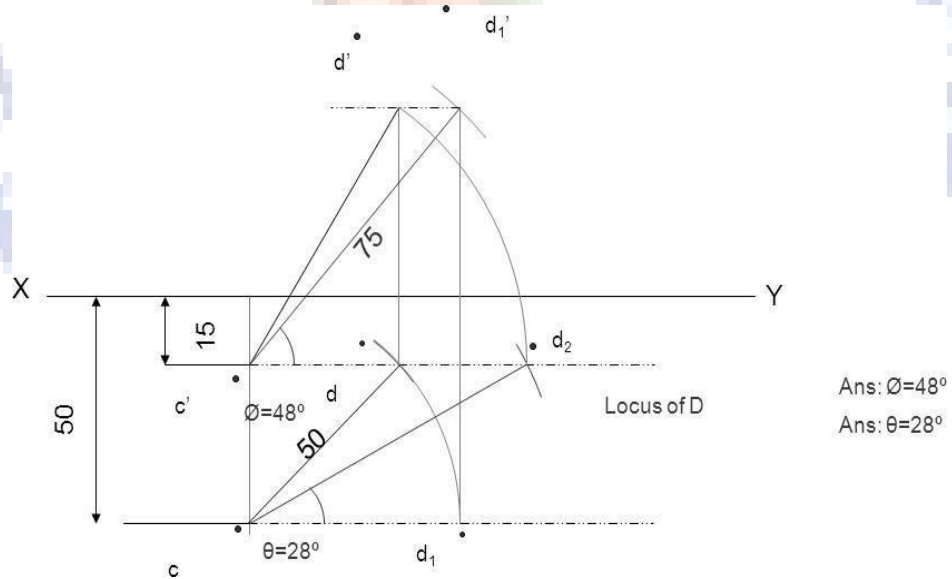

Ans: $\phi = 48^\circ$
 Ans: $\theta = 28^\circ$

Figure 2.17

Problems

1. A line PS 65mm has its end P 15mm above the HP and 15mm in front of the VP. It is inclined at 55 deg to the HP and 35 deg to the VP. Draw its projections.
2. A line CD, inclined at 25deg to the HP, measures 80mm in top view. The end C is in the first quadrant and 25mm and 15mm from the HP and the VP respectively. The end D is at equal distance from the both the reference planes. Draw the projections, find true length and true inclination with the VP.
3. A straight line ST has its end S, 10mm in front of the VP and nearer to it. The mid-point M line is 50mm in front of the VP and 40mm above HP. The front and top view measure 90mm and 120mm respectively. Draw the projection of the line. Also find its true length and true inclinations with the HP and VP.
4. A line PQ has its end P, 10mm above the HP and 20mm in front of the VP. The end Q is 85mm in front of the VP. The front view of the line measures 75mm. the distance between the end projectors is 50mm. Draw the projections of the line and find its true length and its true inclinations with the VP and HP.
5. A line PF, 65mm has its end P, 15mm above the HP and 15mm in front of the VP. It is inclined at 55deg to the VP. Draw its projections.
6. A line CD 60mm long has its end 'C' in both H.P and V.P. It is inclined at 30° to H.P and 45° to V.P. Draw the projections. The front view of line inclined at 30° to V.P is 65mm long. Draw the projections of a line, when it is parallel to and 40mm above H.P. and one end being 20mm in front of V.P.
7. A line PQ, 64 mm long has one of its extremities 20 mm in front VP and the other 50 mm above HP. The line is inclined at 40° to HP and 25° to VP. Draw its top and front view.

PROJECTION OF SOLIDS

A solid has three dimensions, the length, breadth and thickness or height. A solid may be represented by orthographic views, the number of which depends on the type of solid and its orientation with respect to the planes of projection. Solids are classified into two major groups.

- (i) Polyhedral, and
- (ii) Solids of revolution

POLYHEDRAL

A polyhedral is defined as a solid bounded by plane surfaces called faces. They are: (i) Regular polyhedral (ii) Prisms and (iii) Pyramids.

Regular Polyhedral

A polyhedron is said to be regular if its surfaces are regular polygons. The following are some of the regular polyhedral.

To understand and remember various solids in this subject properly, those are classified & arranged in to two major groups.

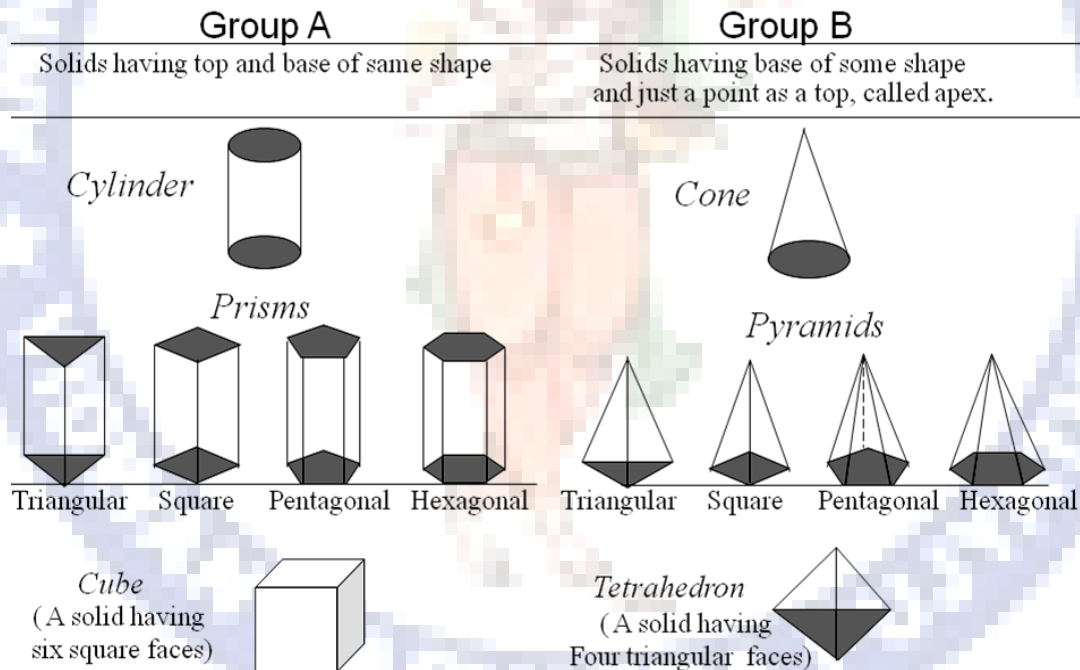

Figure 2.18

Prisms: A prism is a polyhedron having two equal ends called the bases parallel to each other. The two bases are joined by faces, which are rectangular in shape. The imaginary line passing through the centers of the bases is called the axis of the prism. A prism is named after the shape of its base. For example, a prism with square base is called a square prism, the one with a pentagonal base is called a pentagonal prism, and so on (Fig) .

Tetrahedron: It consists of four equal faces, each one being an equilateral triangle.

Hexahedron (cube): It consists of six equal faces, each a square.

Octahedron: It has eight equal faces, each an equilateral triangle.

Dodecahedron: It has twelve regular and equal pentagonal faces.

Icosahedrons: It has twenty equal, equilateral triangular faces.

Pyramids: A pyramid is a polyhedron having one base, with a number of isosceles triangular faces, meeting at a point called the apex. The imaginary line passing through the center of the base and the apex is called the axis of the pyramid.

Dimensional parameters of different solids.

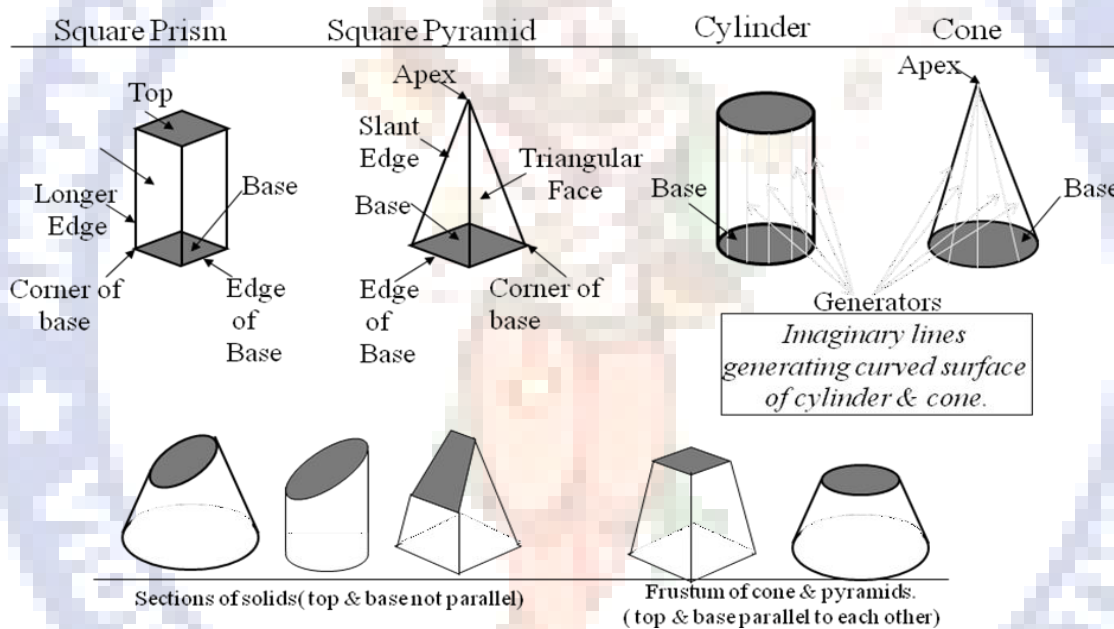

Figure 2.19

The pyramid is named after the shape of the base. Thus, a square pyramid has a square base and pentagonal pyramid has pentagonal base and so on.

Types of Pyramids:

There are many types of Pyramids, and they are named after the shape of their base.

These are Triangular Pyramid, Square Pyramid, Pentagonal pyramid, hexagonal pyramid and tetrahedron

Solids of Revolution: If a plane surface is revolved about one of its edges, the solid generated is called a solid of revolution. The examples are (i) Cylinder, (ii) Cone, (iii) Sphere.

Frustums and Truncated Solids: If a cone or pyramid is cut by a section plane parallel to its base and the portion containing the apex or vertex is removed, the remaining portion is called frustum of a cone or pyramid.

Prisms Position of a Solid with Respect to the Reference Planes: The position of solid in space may be specified by the location of either the axis, base, edge, diagonal or face with the principal planes of projection. The following are the positions of a solid considered.

- Axis perpendicular to HP
- Axis perpendicular to VP
- Axis parallel to both the HP and VP
- Axis inclined to HP and parallel to VP
- Axis inclined to VP and parallel to HP
- Axis inclined to both the Planes (VP. and HP)

The position of solid with reference to the principal planes may also be grouped as follows:

- Solid resting on its base.
- Solid resting on anyone of its faces, edges of faces, edges of base, generators, slant edges, etc.
- Solid suspended freely from one of its corners, etc.

1. Axis perpendicular to one of the principal planes:

When the axis of a solid is perpendicular to one of the planes, it is parallel to the other. Also, the projection of the solid on that plane will show the true shape of the base. When the axis of a solid is perpendicular to H.P, the top view must be drawn first and then the front view is projected from it. Similarly when the axis of the solid is perpendicular to V.P, the front view must be drawn first and then the top view is projected from it.

Problem is solved in three steps:

STEP 1: ASSUME SOLID STANDING ON THE PLANE WITH WHICH IT IS MAKING INCLINATION.

(IF IT IS INCLINED TO HP, ASSUME IT STANDING ON HP)

(IF IT IS INCLINED TO VP, ASSUME IT STANDING ON VP)

IF STANDING ON HP - IT'S TV WILL BE TRUE SHAPE OF IT'S BASE OR TOP:

IF STANDING ON VP - IT'S FV WILL BE TRUE SHAPE OF IT'S BASE OR TOP

BEGIN WITH THIS VIEW:

IT'S OTHER VIEW WILL BE A RECTANGLE (IF SOLID IS *CYLINDER OR ONE OF THE PRISMS*):

IT'S OTHER VIEW WILL BE A TRIANGLE (IF SOLID IS *CONE OR ONE OF THE PYRAMIDS*):

DRAW FV & TV OF THAT SOLID IN STANDING POSITION:

STEP 2: CONSIDERING SOLID'S INCLINATION (AXIS POSITION) DRAW IT'S FV & TV.

STEP 3: IN LAST STEP, CONSIDERING REMAINING INCLINATION, DRAW IT'S FINAL FV & TV.

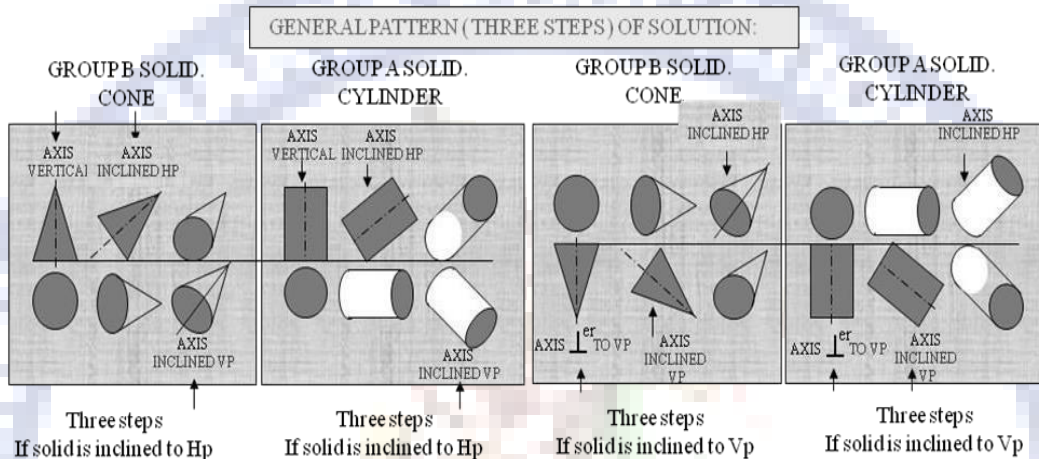

Figure 2.20

Simple Problems:

When the axis of solid is perpendicular to one of the planes, it is parallel to the other. Also, the projection of the solid on that plane will show the true shape of the base. When the axis of a solid is perpendicular to H.P, the top view must be drawn first and then the front view is projected from it. Similarly when the axis of the solid is perpendicular to V.P, the front view must be drawn first and then the top view is projected from it.

Axis perpendicular to HP

Problem:

A Square Pyramid, having base with a 40 mm side and 60mm axis is resting on its base on the HP. Draw its Projections when (a) a side of the base is parallel to the VP. (b) A side of the base is inclined at 30° to the VP and (c) All the sides of base are equally inclined to the VP.

Solution:

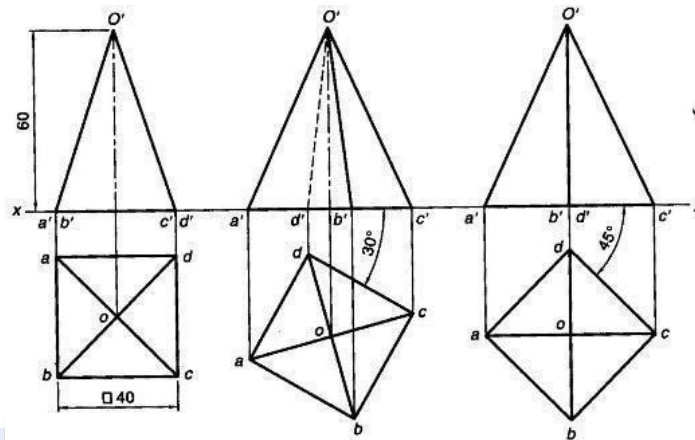

Figure 2.21

Axis perpendicular to VP

Problem:

A pentagonal Prism having a base with 30 mm side and 60mm long Axis, has one of its bases in the VP. Draw its projections when (a) rectangular face is parallel to and 15 mm above the HP (b) A rectangular face perpendicular to HP and (c) a rectangular face is inclined at 45° to the HP Solution:

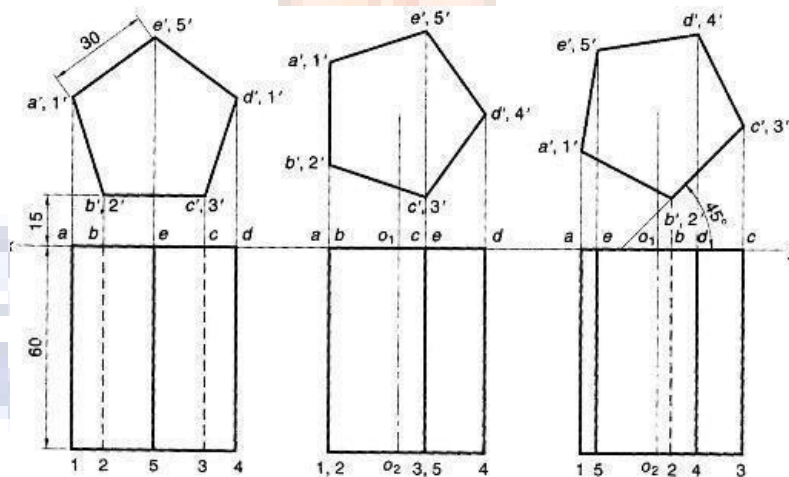

Figure 2.21

Axis inclined to HP and parallel to VP

Problem:

A Hexagonal Prism having a base with a 30 mm side and 75 mm long axis, has an edge its base on the HP. Its axis is parallel to the VP and inclined at 45° to the HP. Draw its projections?

Solution:

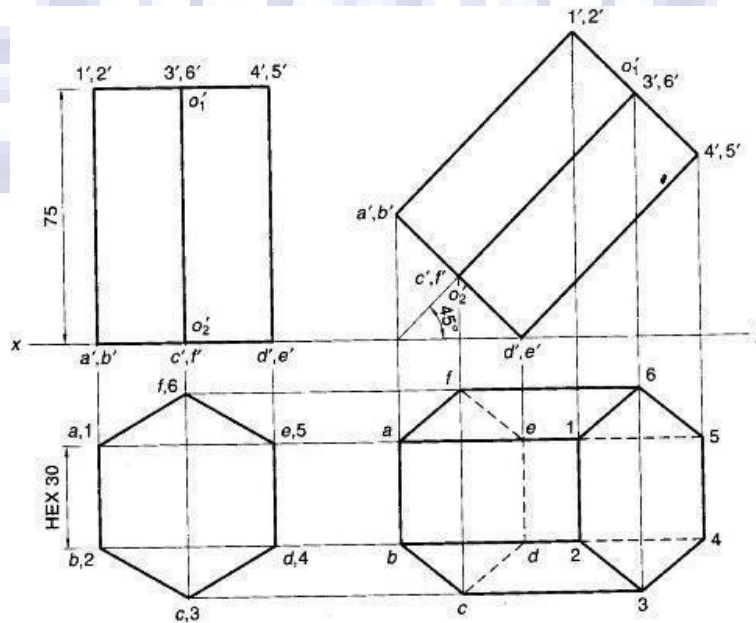

Figure 2.22

Problem:

A cube of 50 mm long edges is so placed on HP on one corner that a body diagonal is parallel to HP and perpendicular to VP. Draw its projections.

Solution Steps:

- Assuming standing on HP, begin with TV, a square with all sides equally inclined to xy. Project Fv and name all points of FV & TV.
- Draw a body-diagonal joining c' with $3'$ (This can become Parallel to xy)
- From $1'$ drop a perpendicular on this and name it p'
- Draw 2nd Fv in which $1'-p'$ line is vertical means $c'-3'$ diagonal must be horizontal. Now as usual project TV.

- In final TV draw same diagonal is perpendicular to VP as said in problem. Then as usual project final FV.

Solution:

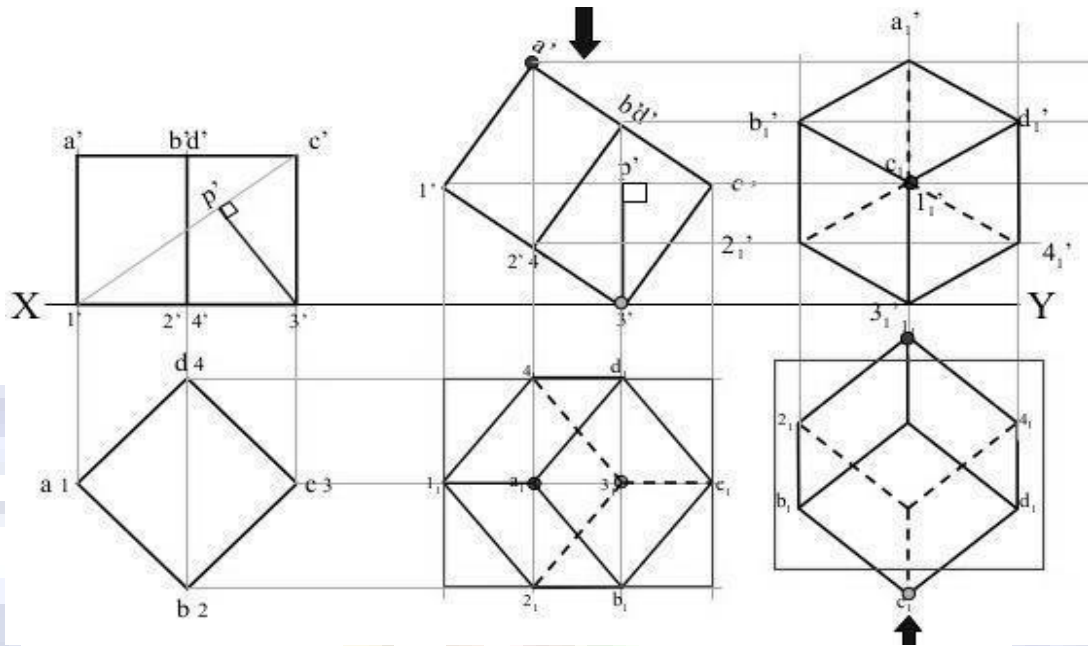

Figure 2.23

Problem:

A cone 40 mm diameter and 50 mm axis is resting on one of its generator on HP which makes 30° inclinations with VP. Draw its projections?

Solution Steps:

- Resting on HP on one generator, means lying on HP
- Assume it standing on HP.
- Its TV will show True Shape of base(circle)
- Draw 40mm dia. Circle as TV & taking 50 mm axis project FV. (a triangle)
- Name all points as shown in illustration.
- Draw 2nd FV in lying position I.e. $o'e'$ on xy. And project its TV below xy.
- Make visible lines dark and hidden dotted, as per the procedure.
- Then construct remaining inclination with VP (generator o_1e_1 30° to xy as shown) & project final FV.

Solution:

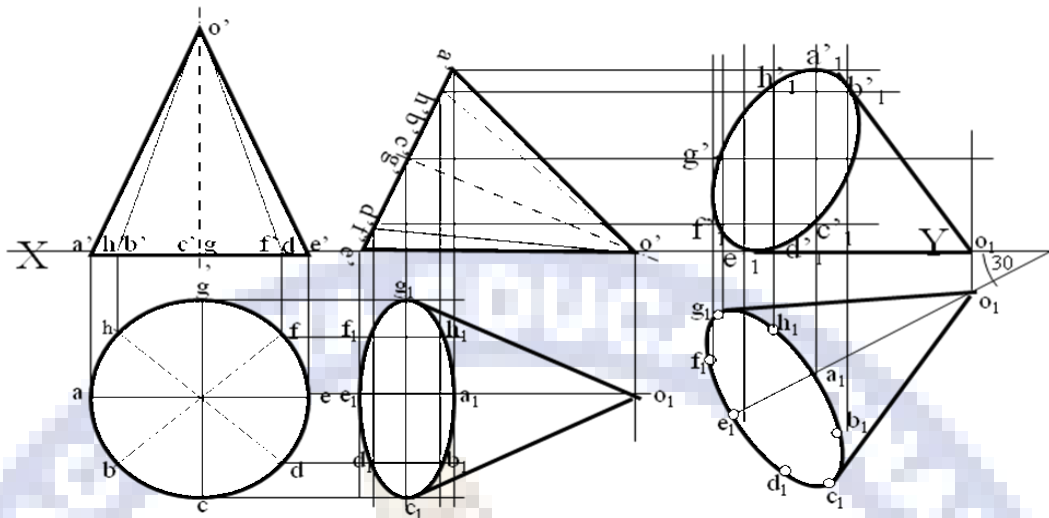

Figure 2.24

Problem

A cube of 50 mm long edges is so placed on HP on one corner that a body diagonal through this corner is perpendicular to HP and parallel to VP. Draw its views.

Solution:

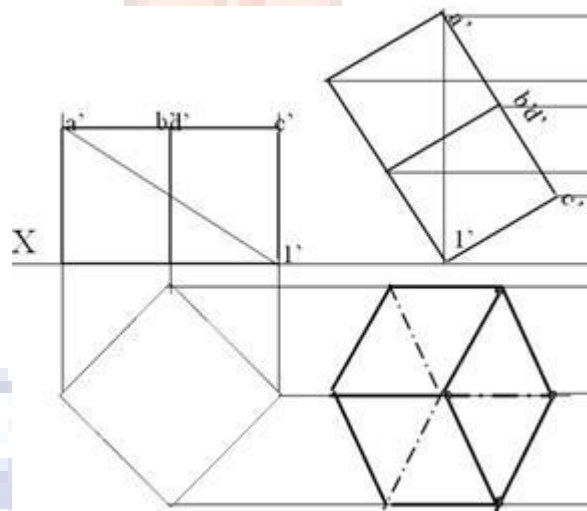

Figure 2.25

Solution Steps:

- Assuming it standing on HP begin with TV, a square of corner case.

- Project corresponding FV & name all points as usual in both views.
- Join $a'l'$ as body diagonal and draw 2nd FV making it vertical (I' on xy)
- Project its TV drawing dark and dotted lines as per the procedure.
- With standard method construct Left-hand side view. (Draw a 45° inclined Line in Tv region (below xy). Project horizontally all points of Tv on this line and reflect vertically upward, above xy . After this, draw horizontal lines, from all points of Fv, to meet these lines. Name points of intersections and join properly. For dark & dotted lines locate observer on left side of Fv as shown.)

Problem:

A circular cone, 40 mm base diameter and 60 mm long axis is resting on HP, on one point of base circle such that its axis makes 45° inclination with HP and 40° inclination with VP. Draw its projections.

Solution:

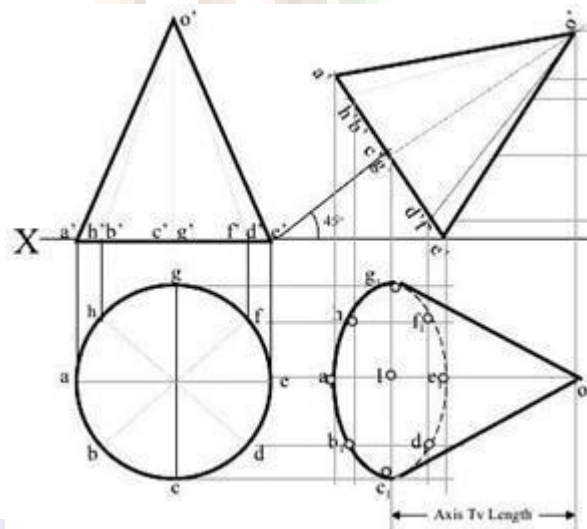

Figure 2.26

Problem

A hexagonal prism, having a base with a 30mm side and an 80mm long axis, rests on one of its base edges in the H.P such that the axis is inclined at 30° to the HP and 45° to the VP. Draw its projections?

Solution:

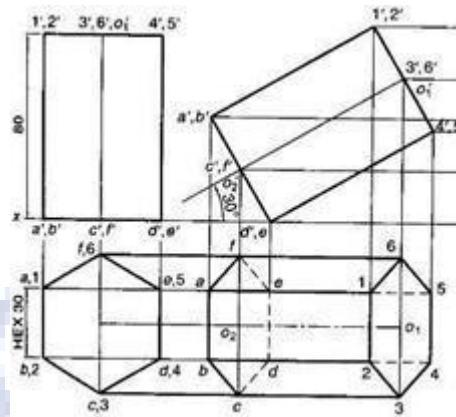

Figure 2.27

Tips & Shortcuts:

1. Axis inclined to HP and Parallel to VP → have to solve in two stages Stage (i) assume axis perpendicular to HP then draw Top and Front view

Stage (ii) Tilt the Front view according to given angle. Then project all the points will get Final Top view

2 Axis inclined to VP and Parallel to HP → have to solve in two stages Stage(i) assume axis perpendicular to VP then draw front and Top view

Stage (ii) Tilt the Top view according to given angle. Then project all the points will get Final Front view

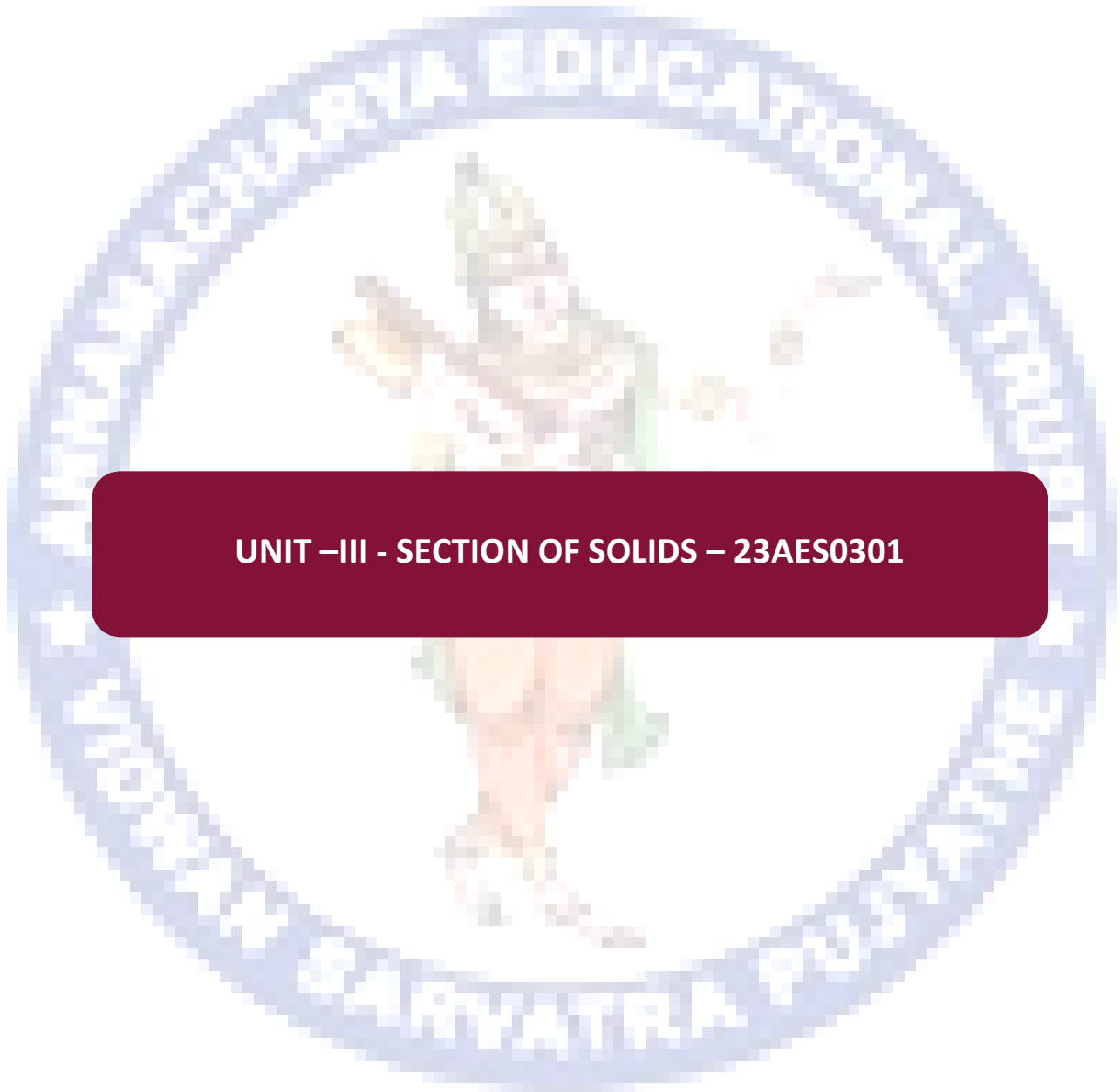

UNIT -III - SECTION OF SOLIDS – 23AES0301

SECTION OF SOLIDS

The hidden or internal parts of an object are shown by sectional views in technical drawings. The sectional view of an object is obtained by cutting through the object by a suitable plane known as the section plane or cutting plane and removing the portion lying between the plane and the observer. The surface produced by cutting the object is called the section and its projection is called a sectional plan or sectional elevation. The section is indicated by thin sectionlines uniformly spaced and inclined at 45° .

A sectional view of an object is obtained by projecting the retained portion of the object which is left behind when object is cut by an imaginary section plane and the portion the object between the section plane and the observer is assumed as removed.

The object is cut by a section plane AA. The front half of the object between the section plane and the observer are removed. The view of the retained portion of the object is projection VP. The topview is projected for the whole uncut object.

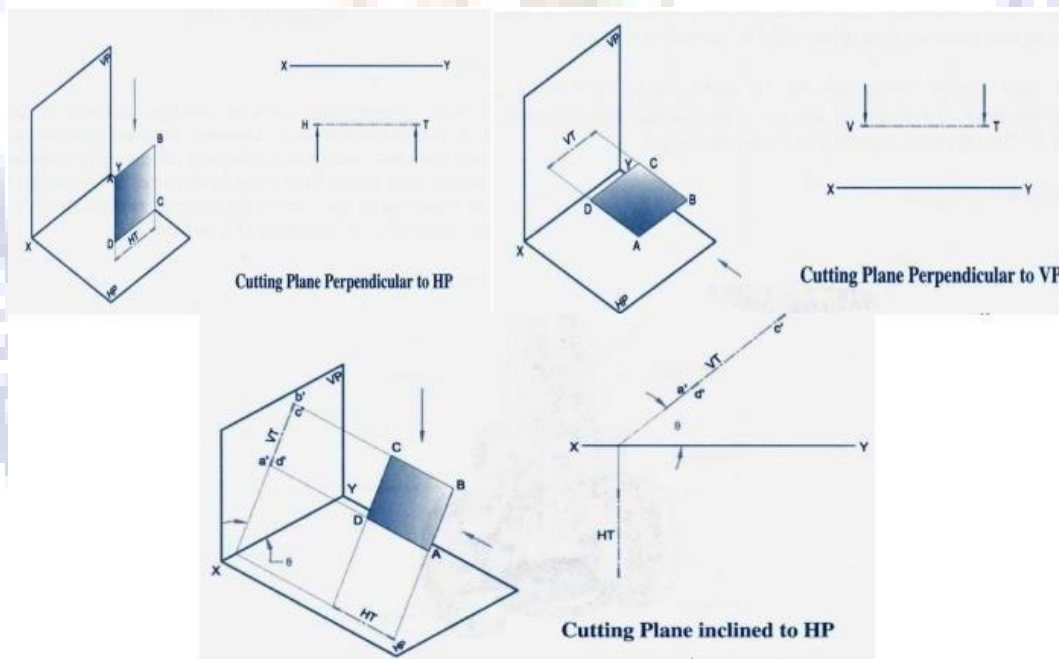

Figure
3.1

Types of sectional views of solids:

By using the five different types of perpendicular section planes we obtain the following five types of sectional views of solids:

1. Section of solids obtained by horizontal planes.

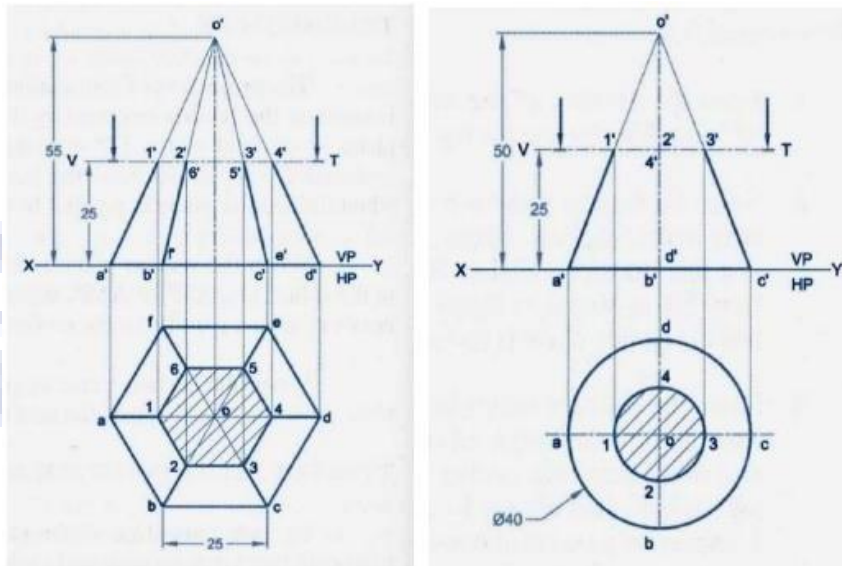

Figure 3.2

2. Section of solids obtained by vertical planes.

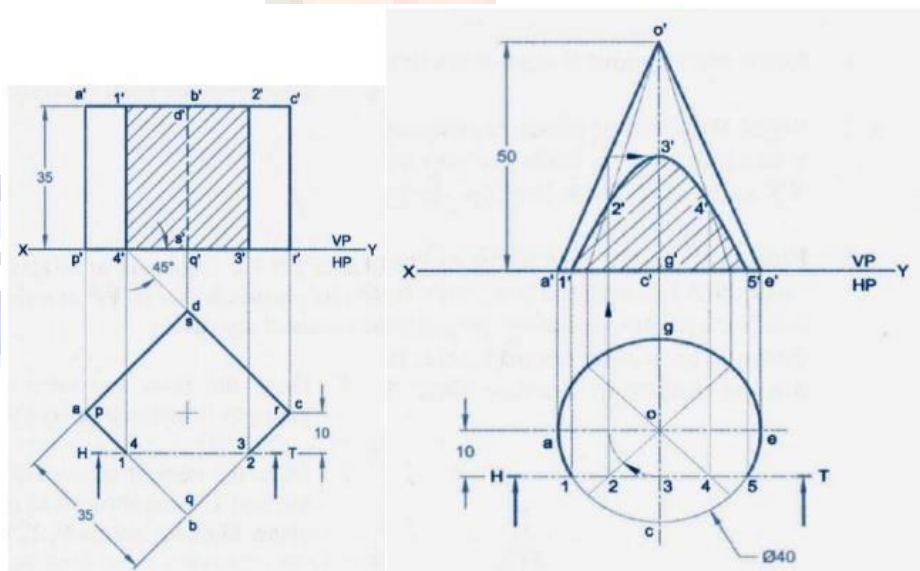

Figure 3.3

TYPES OF SECTION PLANES

A square pyramid 50 mm base side and axis 90 mm long is resting on HP at its base with a side of base parallel to VP. The pyramid is cut by a section plane parallel to HP and perpendicular to VP, bisecting the axis. Draw the sectional views and the true shape of the section.

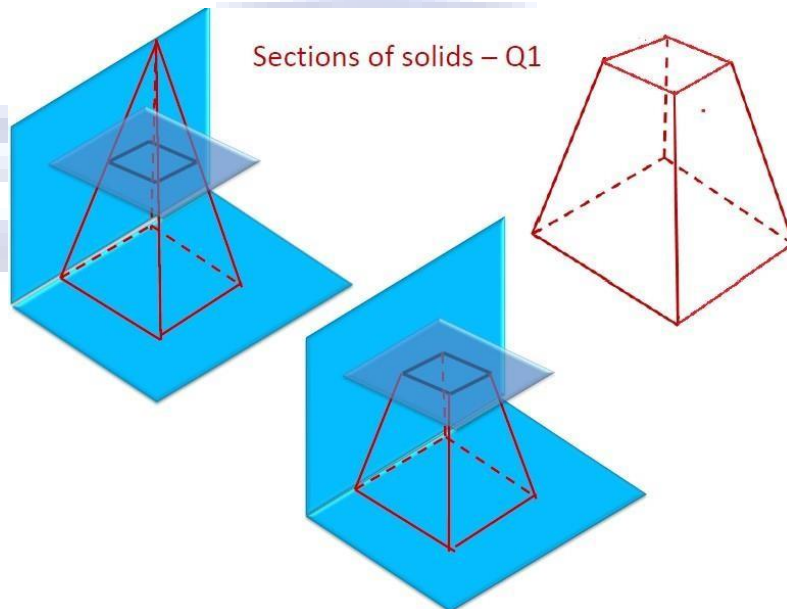

Figure 3.4

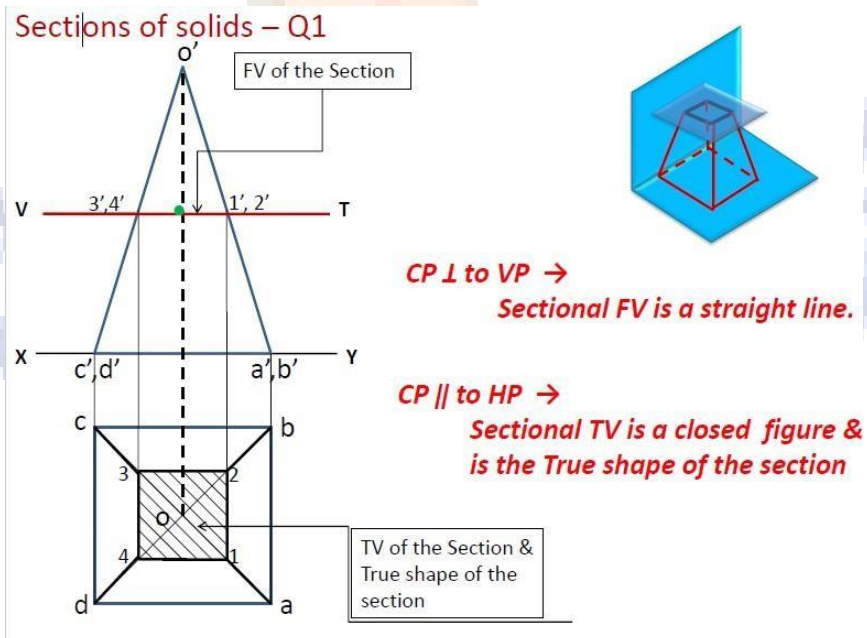

Figure 3.5

A square pyramid 50mm base side and axis 90mm long is resting on HP at its base with a side of base parallel to VP. The pyramid is cut by a section plane inclined at 45° to HP and perpendicular to VP, bisecting the axis. Draw the sectional views and the true shape of the section.

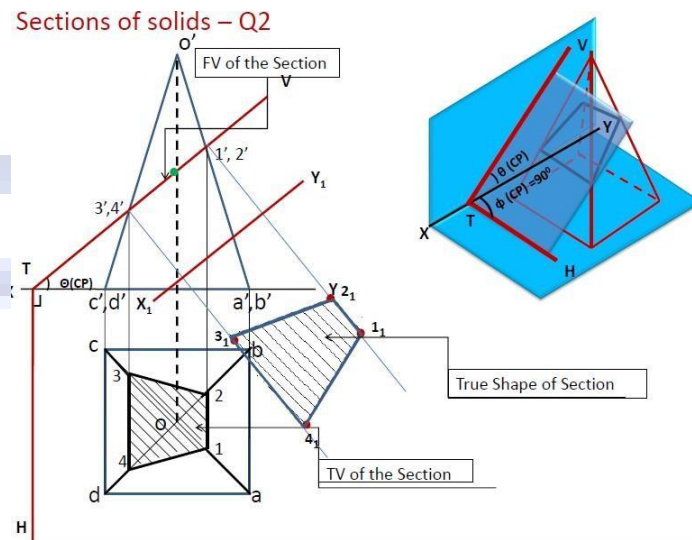

Figure 3.6

A square pyramid 60mm base side and axis 90mm long is resting on HP at its base. The pyramid is cut by a section plane in such a way that the true shape of the section is a trapezium with parallel sides 40mm and 20mm. Draw the FV and TV showing the section. Also show the true shape of the section.

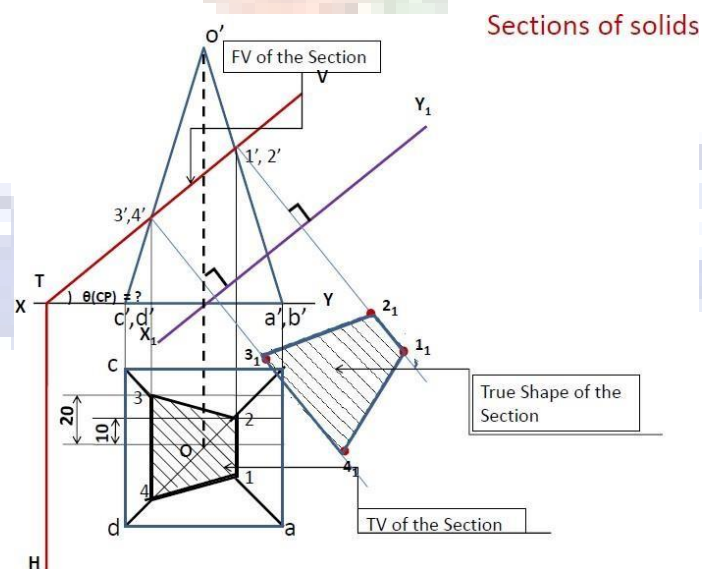

Figure 3.7

A cone is resting on its base on HP. It is cut by a plane inclined 45° to HP and perpendicular to VP. It cuts the axis of the cone at a point 40mm below the vertex. Draw the front view, sectional top view and the true shape of the section, if the diameter of the cone base is 80mm and the length of the axis is 90mm.

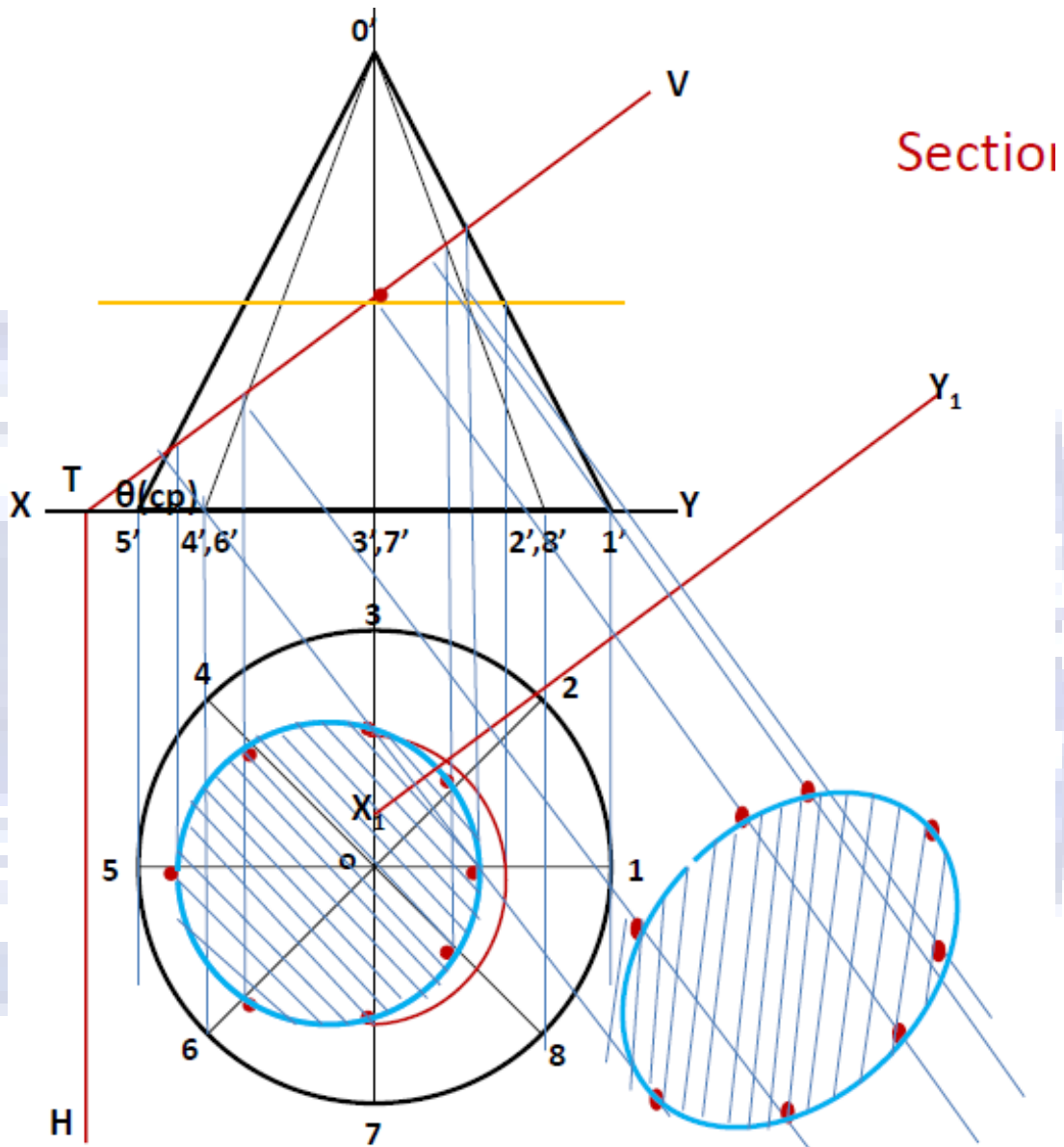

Figure 3.8

A cone of base diameter 120mm and height 135mm is resting on HP on its base. It is cut by an inclined HP such that the true shape obtained is an ellipse whose major axis is 100mm long. Draw the projections of cone showing sectional views and the true shape of the section.

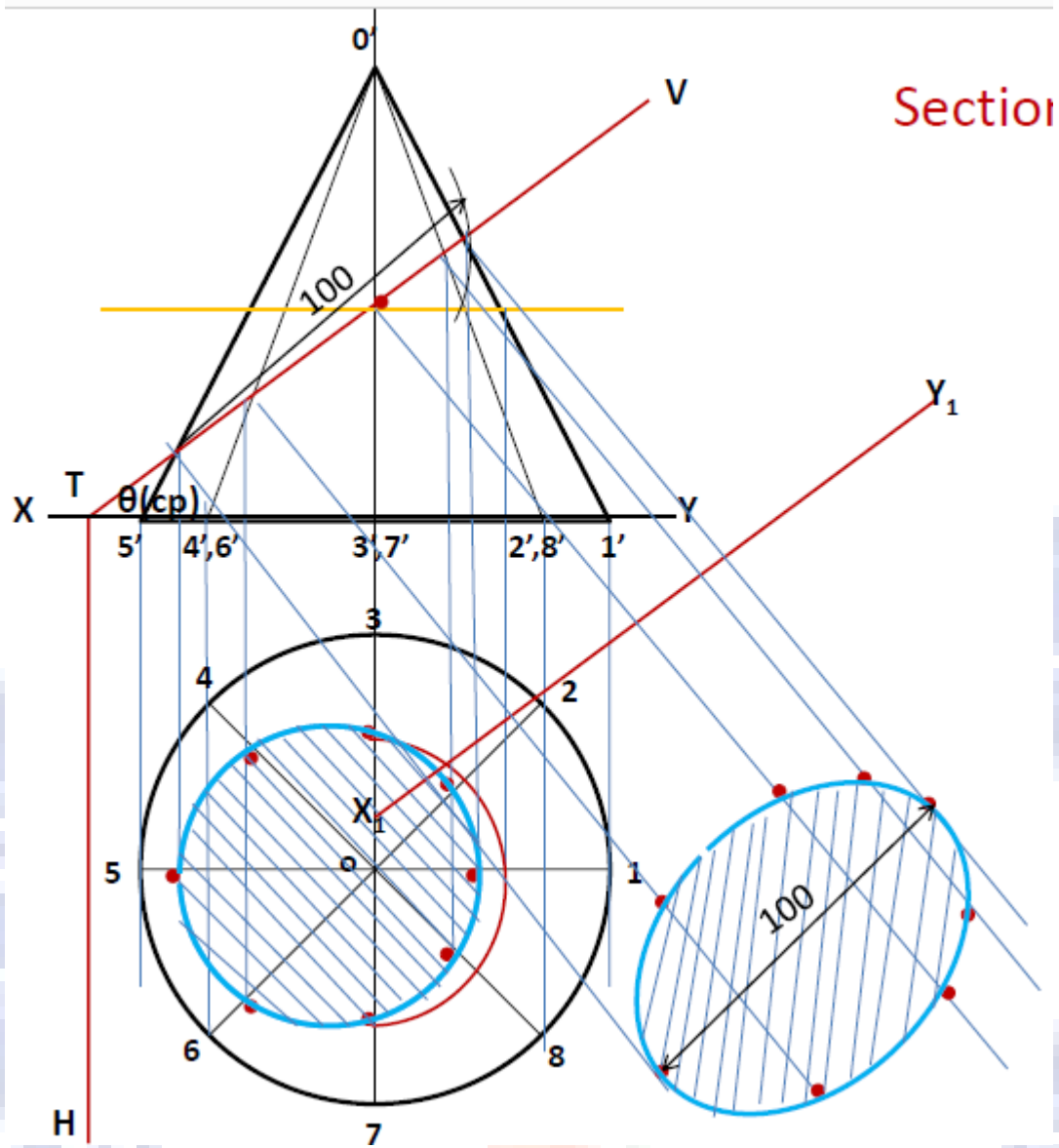

Figure 3.9

A cone base 60mm diameter and axis 70mm stands vertically with its base on HP. The vertical trace of a section plane perpendicular to VP and parallel to one of the end generators of the cone passes at a distance of 15mm from it. Draw the sectional plan and the true shape of the section.

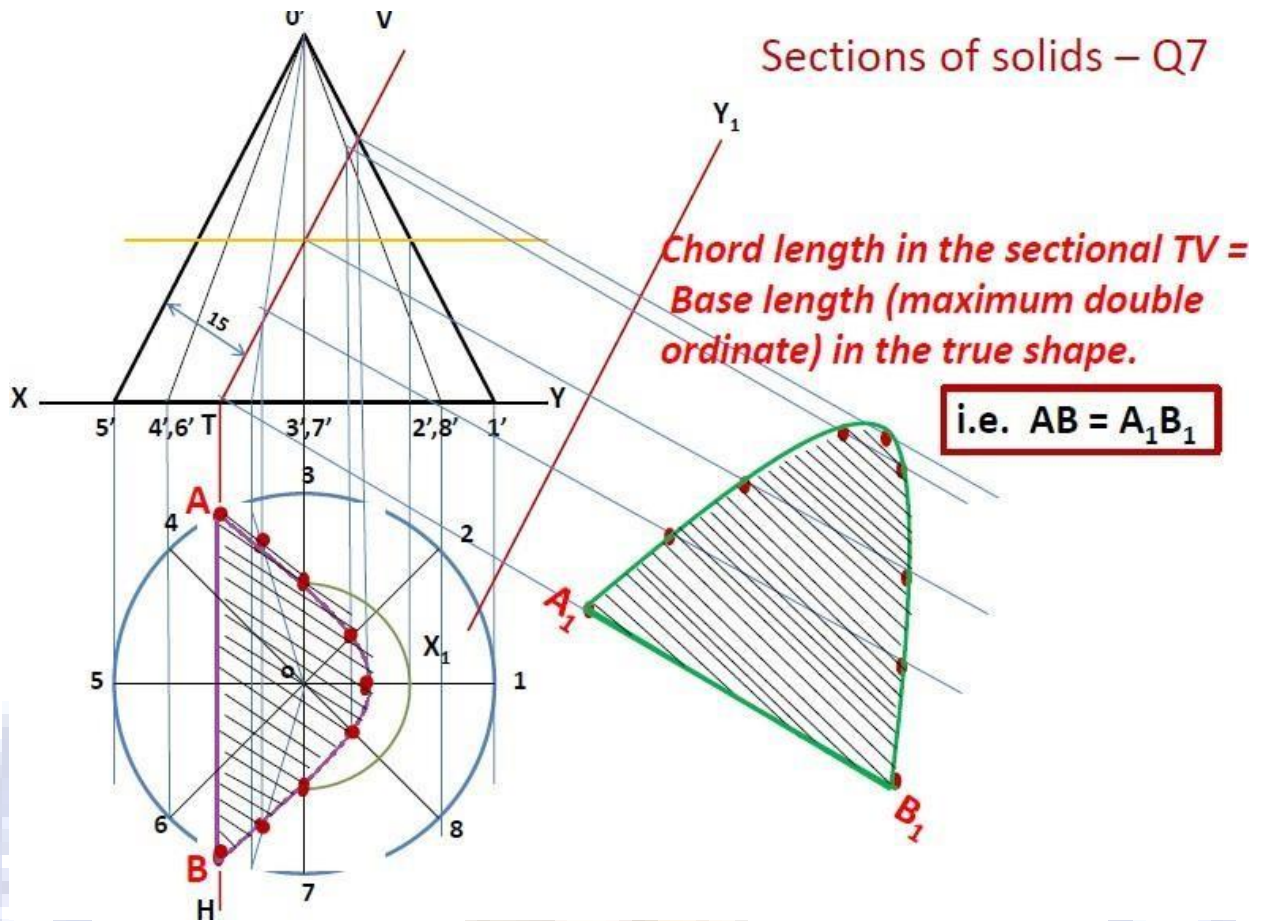

Figure 3.10

A cone of base diameter 50mm and axis 60mm long is resting on HP on its base. It is cut by a section plane such that the true shape is an isosceles triangle of base 40mm. Draw the sectional views and the true shape of the section.

solids – Q10

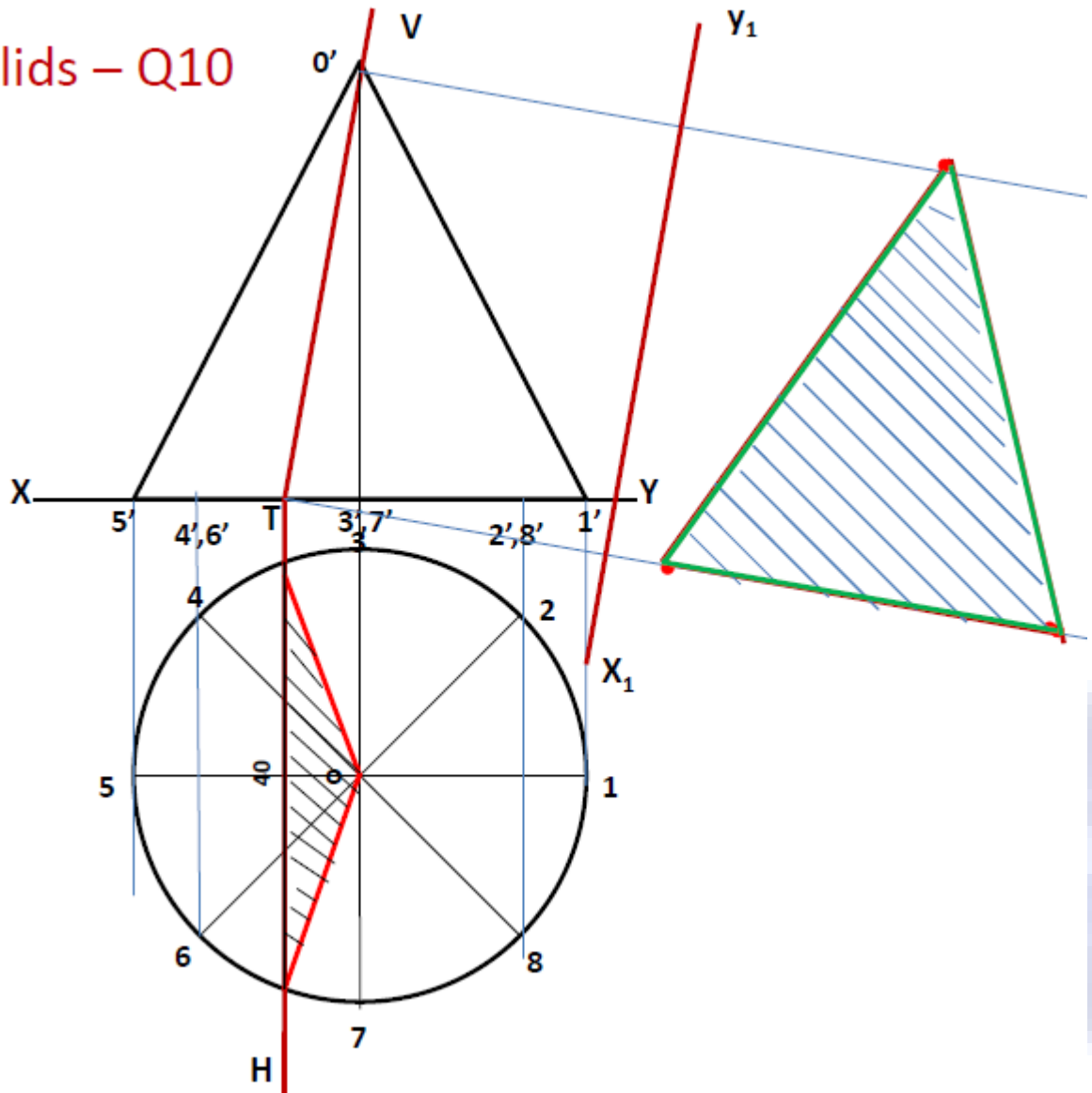
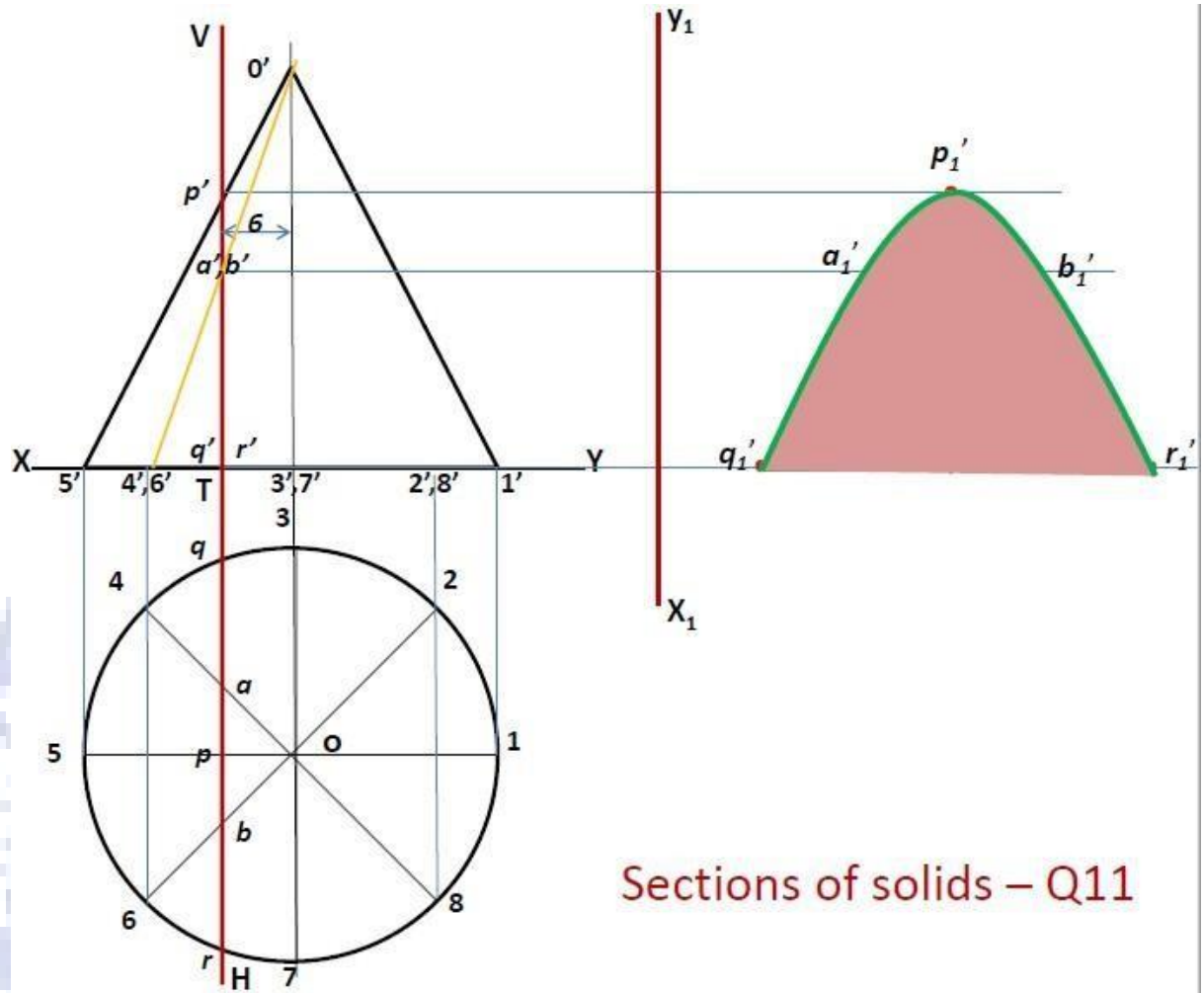

Figure 3.11

A cone of base diameter 50mm and axis 55mm long is resting on HP on its base. It is cut by a section plane perpendicular to both HP and VP and 6mm away from the axis. Show the sectional side view. Mark the height of the section.



Sections of solids – Q11

Figure 3.12

A cone base 60mm diameter and axis 90mm stands vertically with its base on HP. It is cut by a vertical section plane inclined at 30° to VP and passing through a point on the cone 10mm off the axis. Draw the sectional views and the true shape of the section.

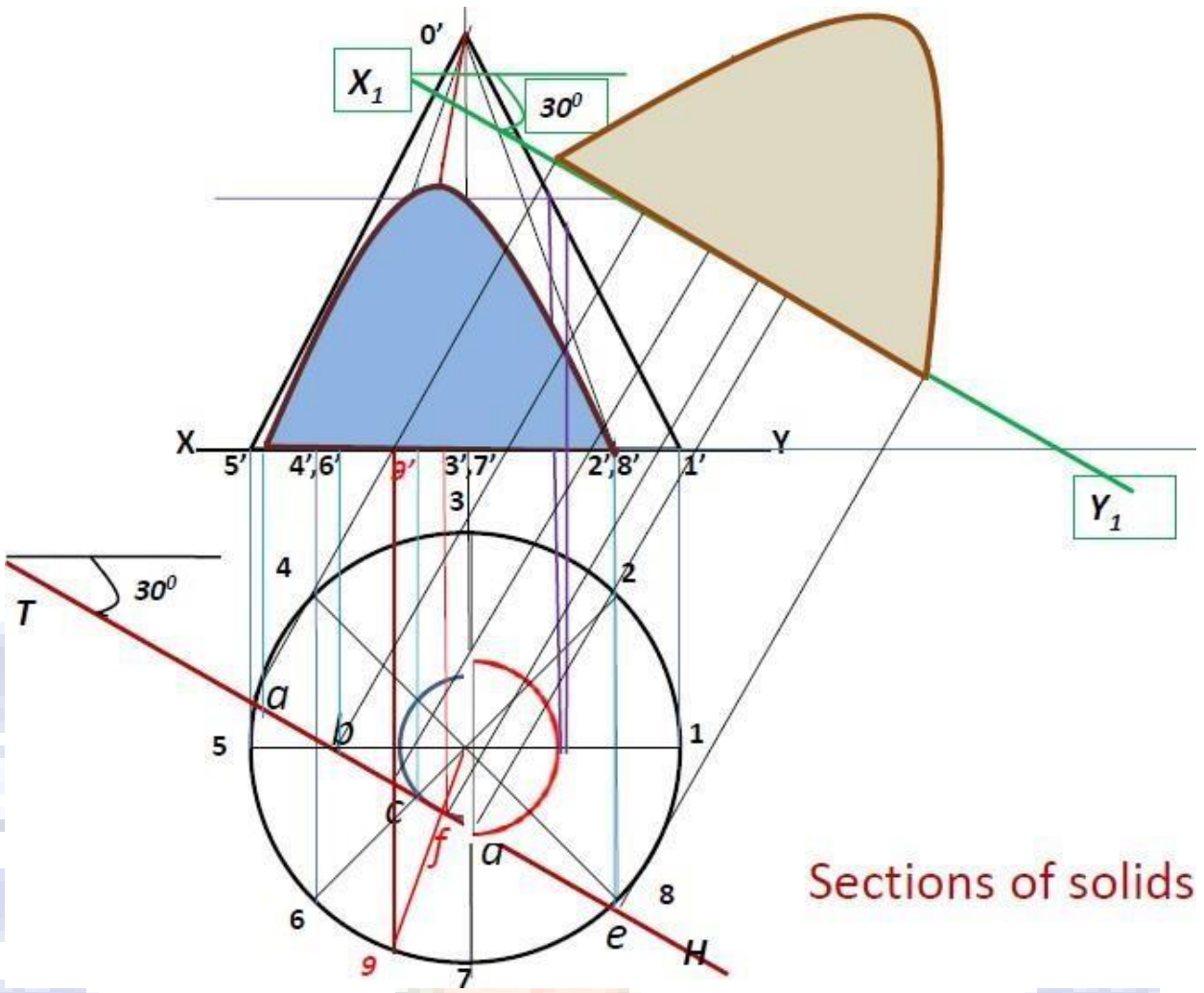

Sections of solids

Figure 3.13

A cube of 50mm side is cut by an inclined plane such that the true shape obtained is a regular hexagon. Draw the sectional views and the true shape of the section.

Sections of solids – Q14

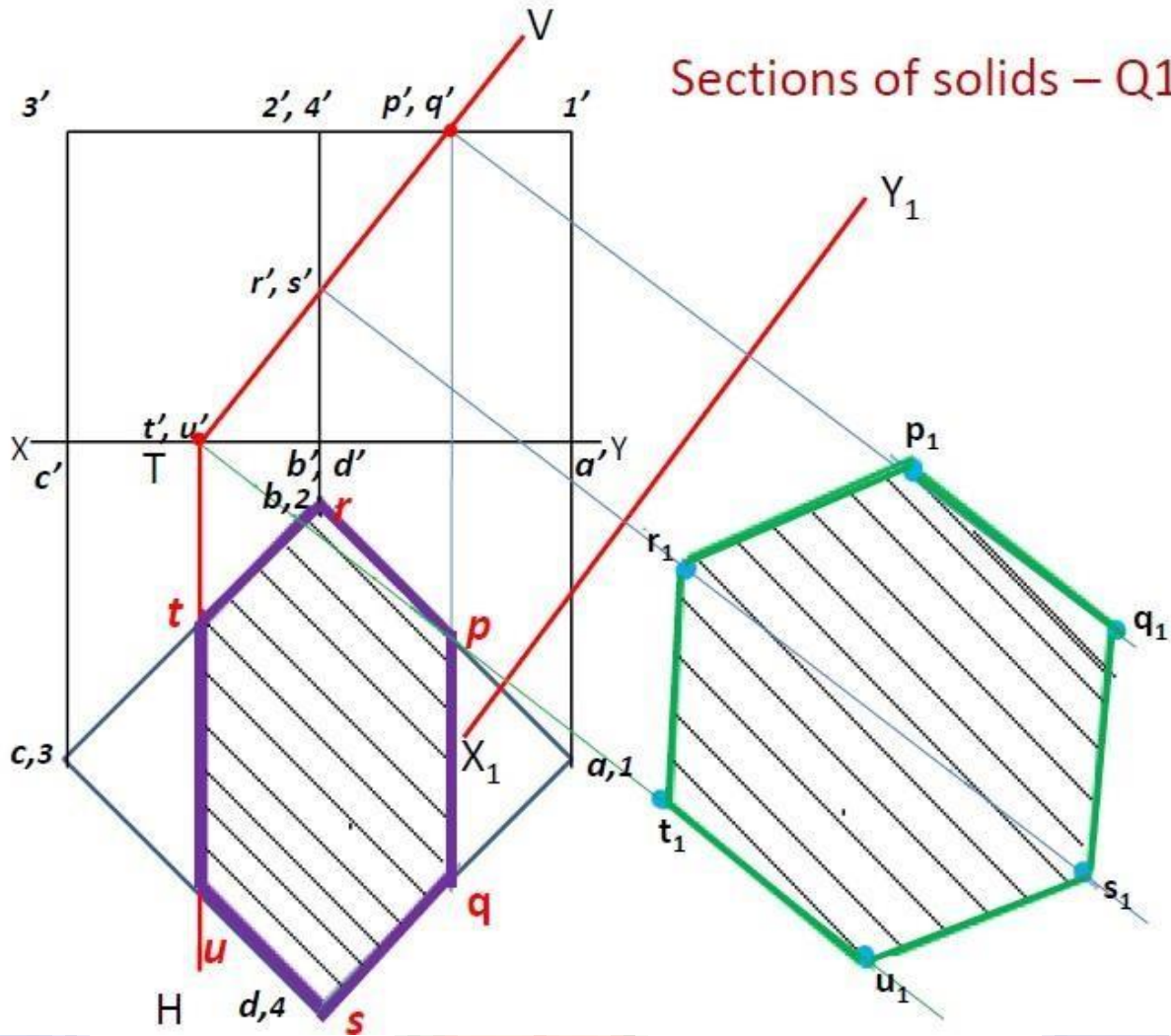

Figure 3.14

A hexagonal pyramid, side of base 30mm and axis 60mm long, is resting on its base on ground with two base edges parallel to VP. It is cut by a vertical plane inclined at 30° to VP and cutting the pyramid 5mm off the axis. Draw the top view, sectional front view and the true shape of the section.

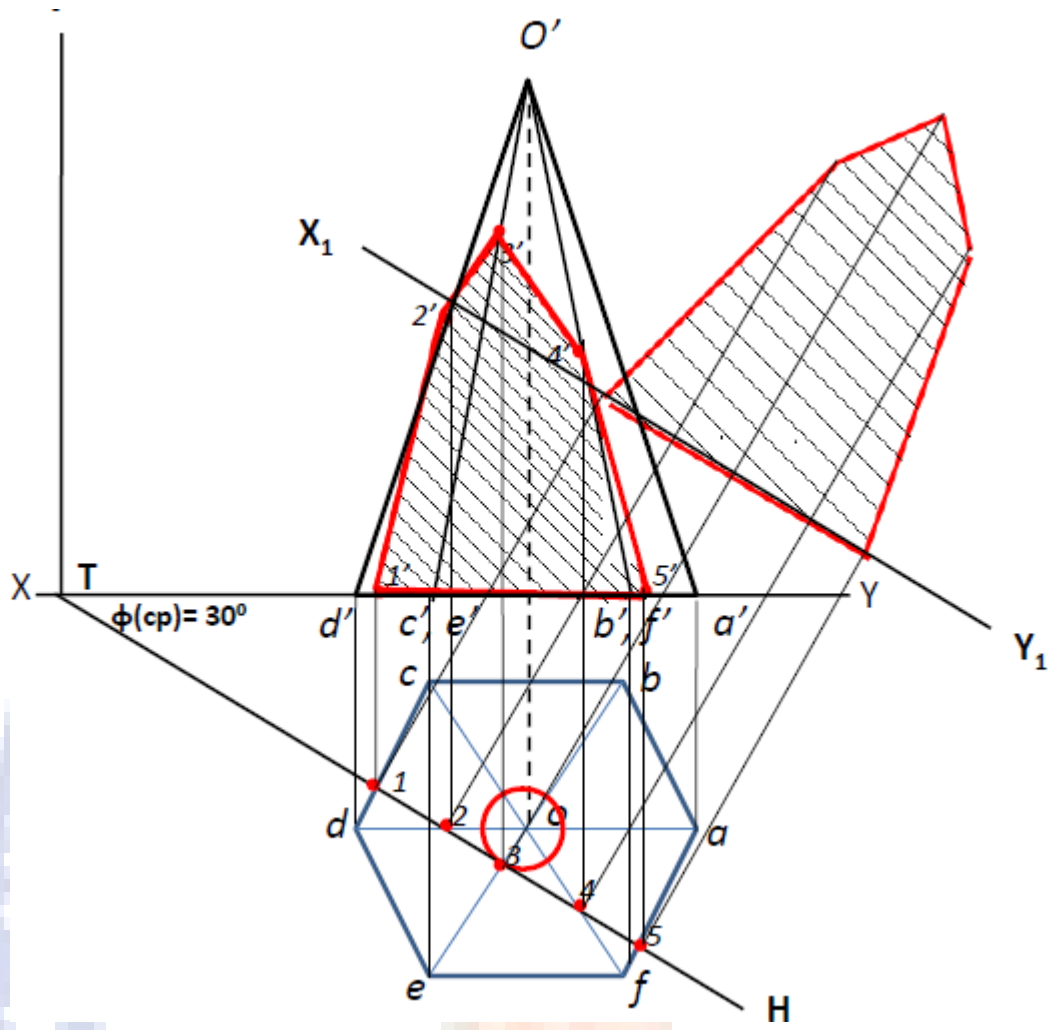
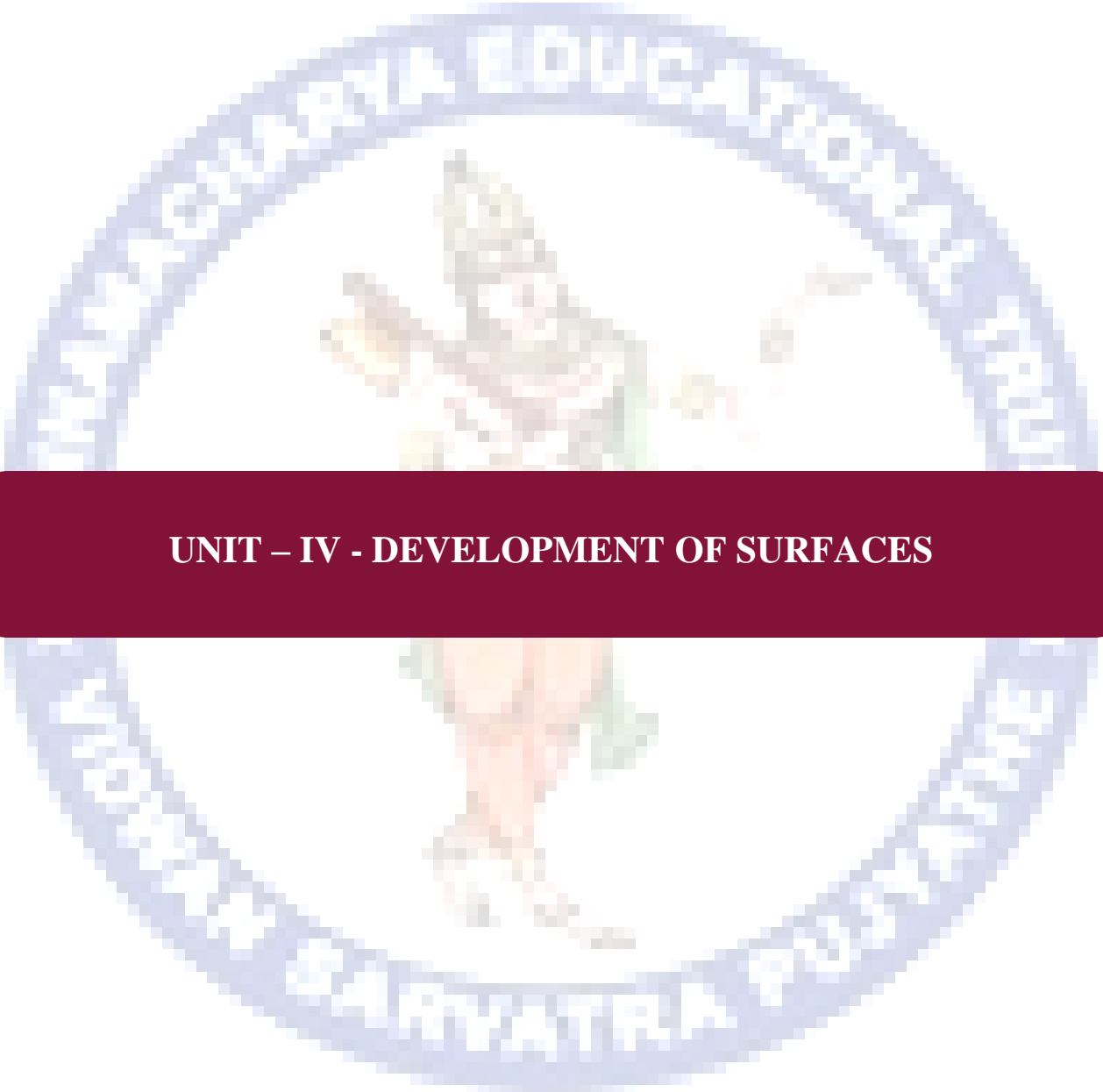

Figure 3.15



UNIT – IV - DEVELOPMENT OF SURFACES

Development of surfaces

A layout of the complete surface of a three dimensional object on a plane is called the development of the surface or flat pattern of the object. The development of surfaces is very important in the fabrication of articles made of sheet metal.

The objects such as containers, boxes, boilers, hoppers, vessels, funnels, trays etc., are made of sheet metal by using the principle of development of surfaces.

In making the development of a surface, an opening of the surface should be determined first. Every line used in making the development must represent the true length of the line (edge) on the object.

The steps to be followed for making objects, using sheet metal are given below:

1. Draw the orthographic views of the object to full size.
2. Draw the development on a sheet of paper.
3. Transfer the development to the sheet metal.
4. Cut the development from the sheet.
5. Form the shape of the object by bending.
6. Join the closing edges.

Methods of Development

The method to be followed for making the development of a solid depends upon the nature of its lateral surfaces. Based on the classification of solids, the following are the methods of development.

1. Parallel-line Development

It is used for developing prisms and single curved surfaces like cylinders in which all the edges / generators of lateral surfaces are parallel to each other.

2. Radial-line Development

It is employed for pyramids and single curved surfaces like cones in which the apex is taken as centre and the slant edge or generator (which are the true lengths) as radius for its development.

Development of Prism

To draw the development of a square prism of side of base 30mm and height 50mm.

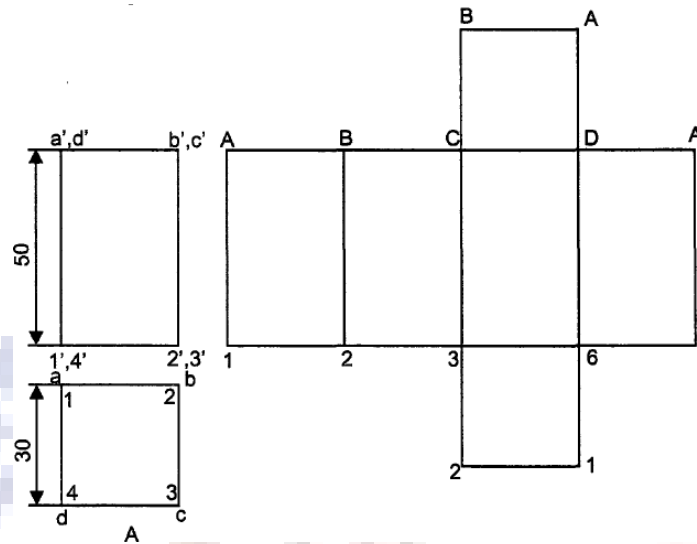

Figure 4.1

1. Assume the prism is resting on its base on H.P. with an edge of the base parallel to V.P and draw the orthographic views of the square prism.
2. Draw the stretch-out line 1-1 (equal in length to the circumference of the square prism) and mark off the sides of the base along this line in succession i.e. 1-2, 2-3, 3-4 and 4-1.
3. Erect perpendiculars through 1, 2, 3 etc., and mark the edges (folding lines) I-A, 2-B, etc., equal to the height of the prism 50 mm.
4. Add the bottom and top bases 1234 and ABCD by the side of an) of the base edges.

Development of a square pyramid with side of base 30 mm and height 60 mm.

Construction

1. Draw the views of the pyramid assuming that it is resting on H.P and with an edge of the base parallel to V.P.
2. Determine the true length of the slant edge.

Note:

In the orientation given for the solid, all the slant edges are inclined to both H.P and V.P. Hence, neither the front view nor the top view provides the true length of the slant edge. To determine the true length of the slant edge, say OA, rotate oa till it is parallel to xy to the position.oal. Through a l ' draw a projector to meet the line xy at all' Then Oil all represents the true length of the slant edge OA. This method of determining the true length is also known as rotation

method.

3. with centre O and radius olal draw an arc.
4. Starting from A along the arc, mark the edges of the base ie. AB, BC, CD and DA.
5. Join O to A,B,C, etc., representing the lines of folding and thus completing the development.

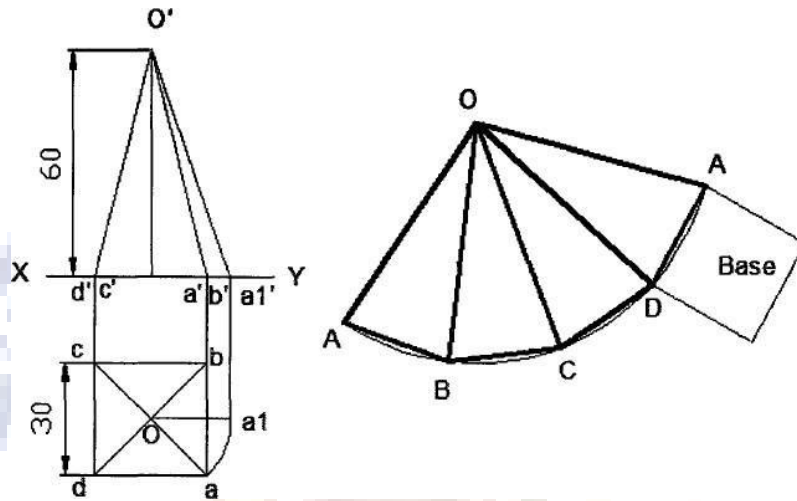

Figure 4.2

Problem: A Pentagonal prism of side of base 20 mm and height 50 mm stands vertically on its base with a rectangular face perpendicular to V.P. A cutting plane perpendicular to V.P and inclined at 60° to the axis passes through the edges of the top base of the prism. Develop the lower portion of the lateral surface of the prism.

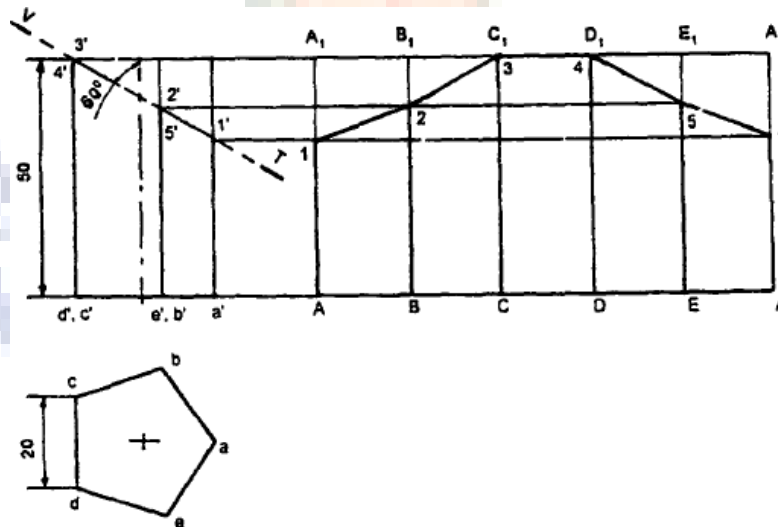

Figure 4.3

1. Draw the projections of the prism.
2. Draw the trace (V.T) of the cutting plane intersecting the edges at points 1,2,3, etc.
3. Draw the stretch-out AA and mark-off the sides of the base along this in succession i.e., AB,

BC, CD, DE and EA.

4. Erect perpendiculars through A,B,C etc., and mark the edges AA₁, BB₁ equal to the height of the prism.
5. Project the points 1₁,2₁,3₁ etc., and obtain 1,2,3 etc., respectively on the corresponding edges in the development.
6. Join the points 1,2,3 etc., by straight lines and darken the sides corresponding to the truncated portion of the solid.

Problem: A hexagonal prism of side of base 30 mm and axis 70 mm long is resting on its base on HP. such that a rectangular face is parallel to v.P. It is cut by a section plane perpendicular to v.p and inclined at 30° to HP. The section plane is passing through the top end of an extreme lateral edge of the prism. Draw the development of the lateral surface of the cut prism.

1. Draw the projections of the prism.
2. Draw the section plane VT.
3. Draw the development AAI-AIA of the complete prism following the stretch out line principle.
4. Locate the point of intersection 1₁,2₁ etc., between VT and the edges of the prism.
5. Draw horizontal lines through 1₁,2₁ etc., and obtain 1,2, etc., on the corresponding edges in the development.
6. Join the points 1,2, etc., by straight lines and darken the sides corresponding to the retained portion of the solid.

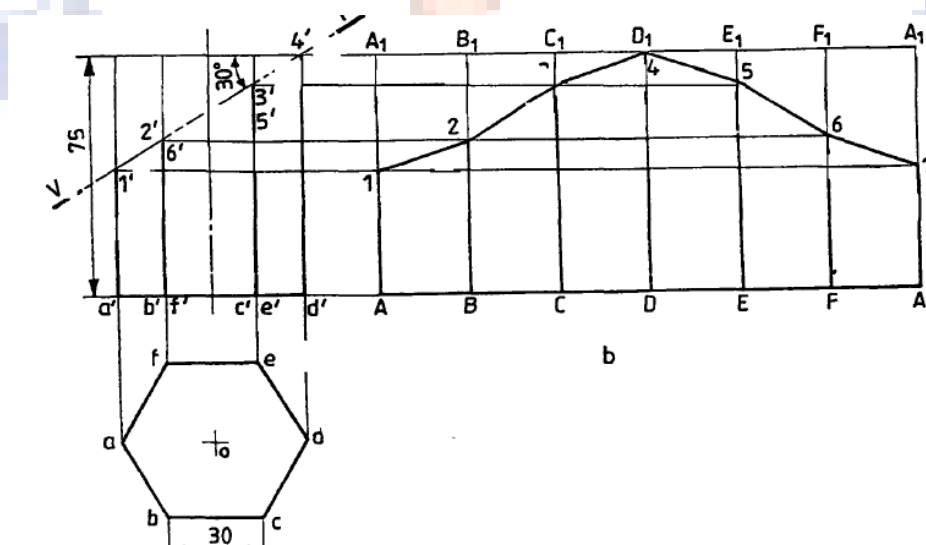

Figure 4.4

Problem: Draw the development of the lateral surface of the frustum of the square pyramid of side of base 30 mm and axis 40 mm, resting on HP with one of the base edges parallel to v.P. It is cut by a horizontal cutting plane at a height of 20 mm.

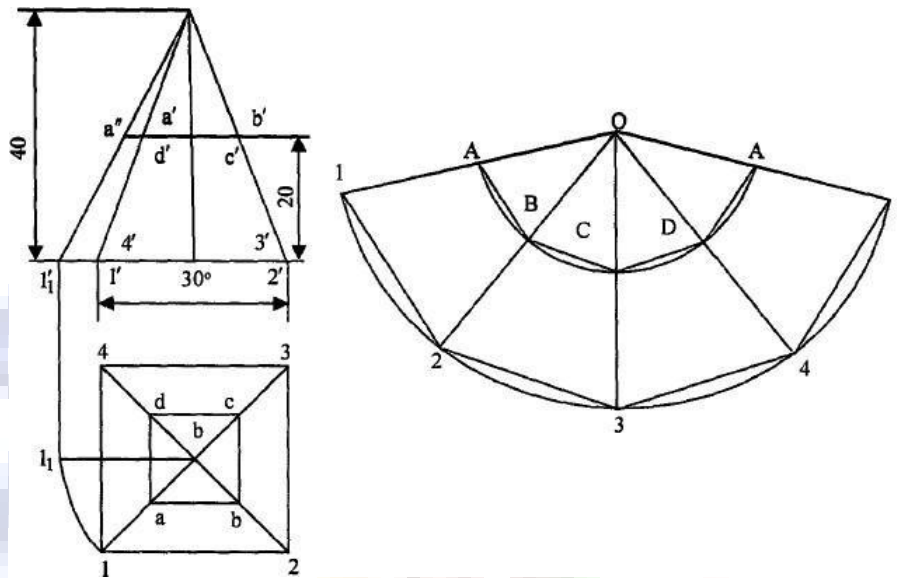

Figure 4.5

1. Draw the projections of the square pyramid.
2. Determine the true length. o-a of the slant edge.
3. Draw the trace of the cutting plane VT.
4. Locate the points of intersection of the cutting plane on the slant edges a₁b₁c₁d₁ of the pyramid.
5. With any point O as centre and radius equal to the true length of the slant edge draw an arc of the circle.
6. With radius equal to the side of the base 30 mm, step-off divisions on the above arc.
7. Join the above division points 1,2,3 etc., in the order with the centre of the arc o. The full development of the pyramid is given by O 12341.
8. With centre O and radius equal to oa mark-off these projections at A, B, C, D, A. Join A-B, B-C etc. ABCDA-12341 is the development of the frustum of the square pyramid.

Problem: A hexagonal pyramid with side of base 30 mm and height 75 mm stands with its base on RP and an edge of the base parallel to v.P. It is cut by a plane perpendicular to v.p, inclined at 45° to H.P and passing through the mid-point of the axis. Draw the (sectioned) top view and develop the lateral surface of the truncated pyramid

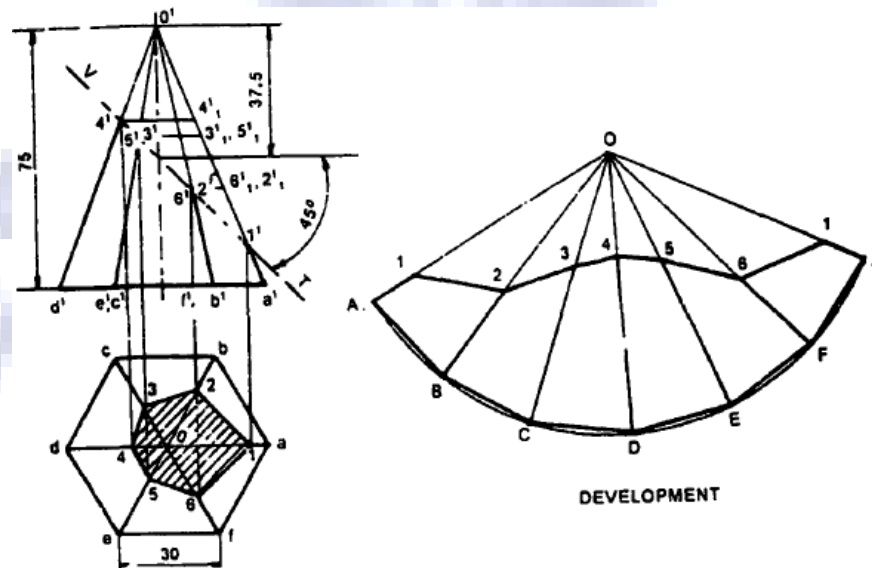

Figure 4.6

1. Draw the two views of the given pyramid and indicate the cutting plane.
2. Locate the points of intersection 1, 2, 3, 4, 5, 6 between the slant edges and the cutting plane.
3. Obtain the sectional top view by projecting the above points.
4. With O as centre and radius equal to the true length of the slant edge draw an arc and complete the total development by following construction of Fig. 7.8.
5. Determine the true length $O1, O2, O3, \dots$, of the slant edges $O1, O2, O3, \dots$, etc.

Development of Cylinder

Draw the development of the complete surface of a **cylindrical drum**. Diameter is 40 mm and height 60 mm.

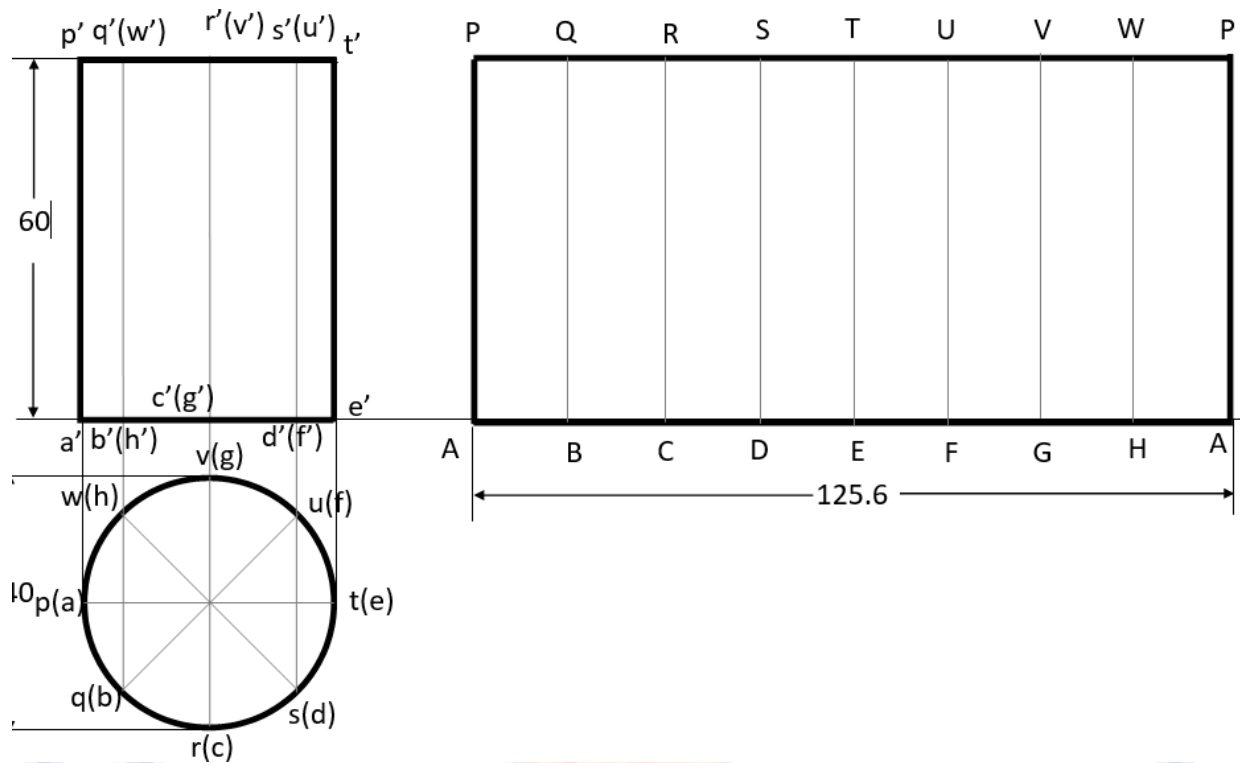

Figure 4.7

A hexagonal prism of base side 20 mm and height 45 mm is resting on one of its ends on the HP with two of its lateral faces parallel to the VP. It is cut by a plane perpendicular to the VP and inclined at 30° to the HP. The plane meets the axis at a distance of 20 mm above the base. Draw the development of the lateral surfaces of the lower portion of the prism. Page no 300

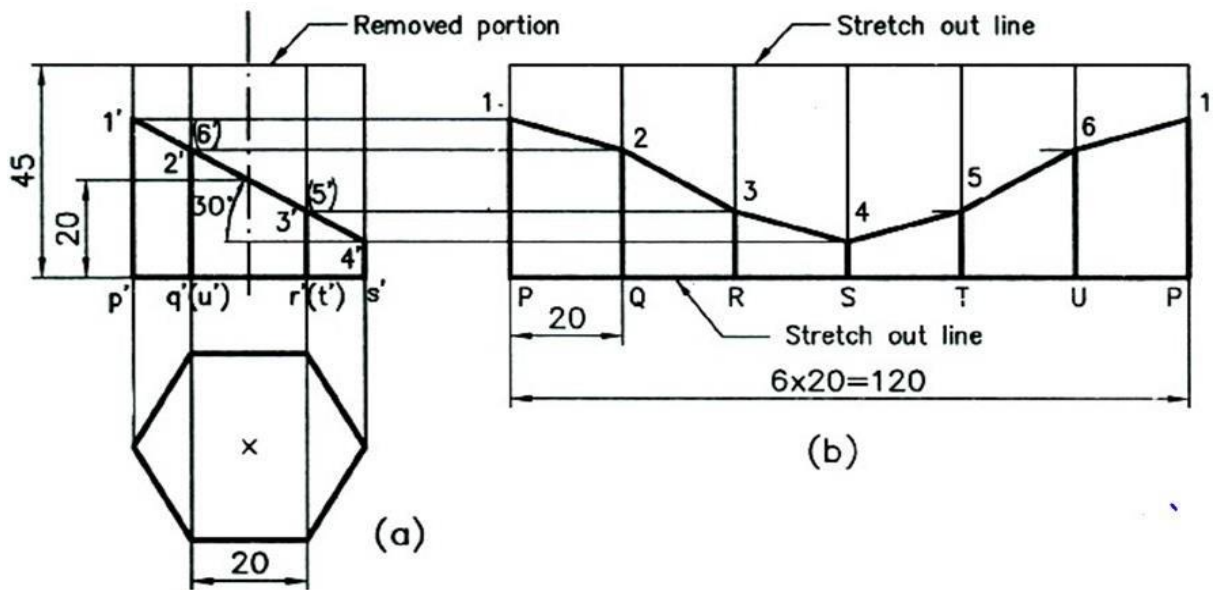

Figure 4.8

A **pentagonal prism**, side of base 25 mm and altitude 50 mm, rests on its base on the HP such that an edge of the base is parallel to VP and nearer to the observer. It is cut by a plane inclined at **45° to HP**, perpendicular to VP and passing **through the center of the axis**. Draw the development of the complete surfaces of the truncated prism.

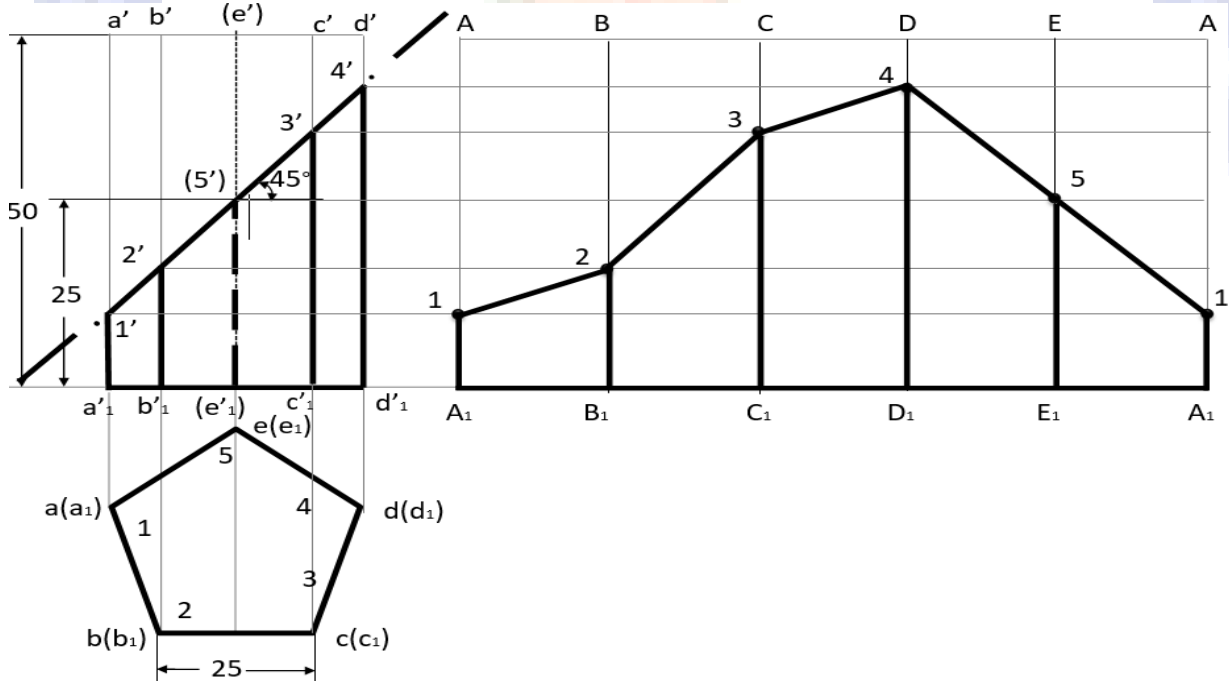

Figure 4.9

Draw the development of the lateral surface of the lower portion of a cylinder of diameter 50 mm and axis 70 mm when sectioned by a plane inclined at 40° to HP and perpendicular to VP and bisecting axis.

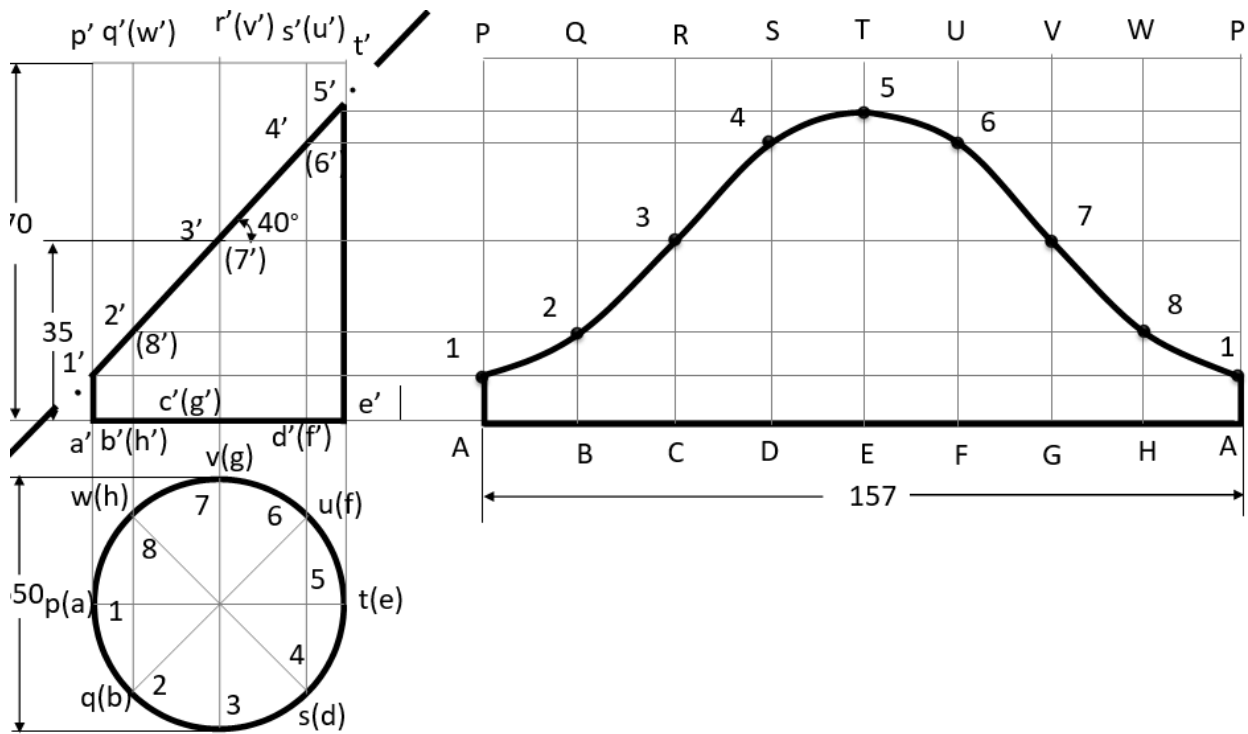

Figure 4.10

Draw the development of the lateral surface of a **cone** of base diameter 48 mm and altitude 55 mm.

$$= (\text{Base circle radius} / \text{True slant length}) * 360^\circ$$

$$= (24 / 60) * 360^\circ$$

$$= 144^\circ$$

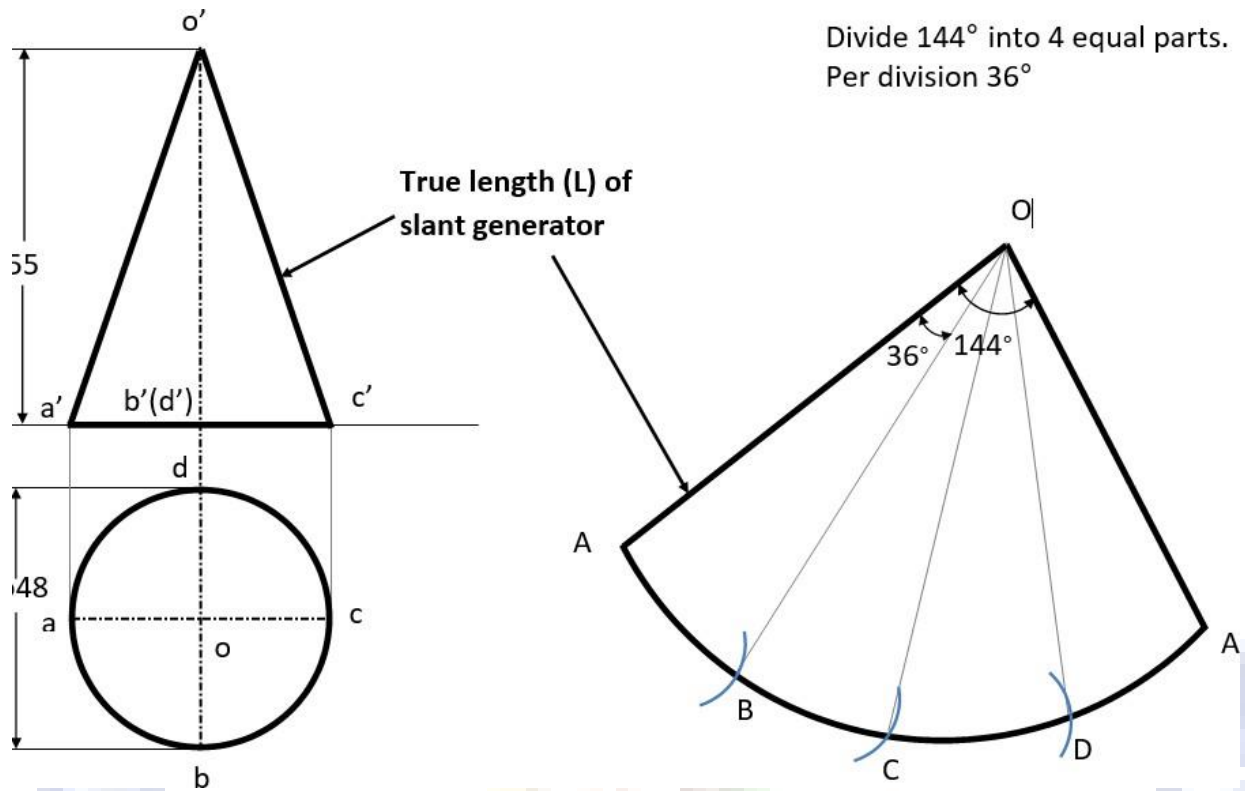

Figure 4.11

A regular **hexagonal pyramid** of side of base 30 mm and height 60 mm is resting vertically on its base on HP such that two of the sides of the base are perpendicular to VP. It is cut by a plane inclined at **40° to HP** and perpendicular to VP. The cutting plane **bisects the axis** of the pyramid. Obtain the development of the lateral surface of the truncated pyramid.

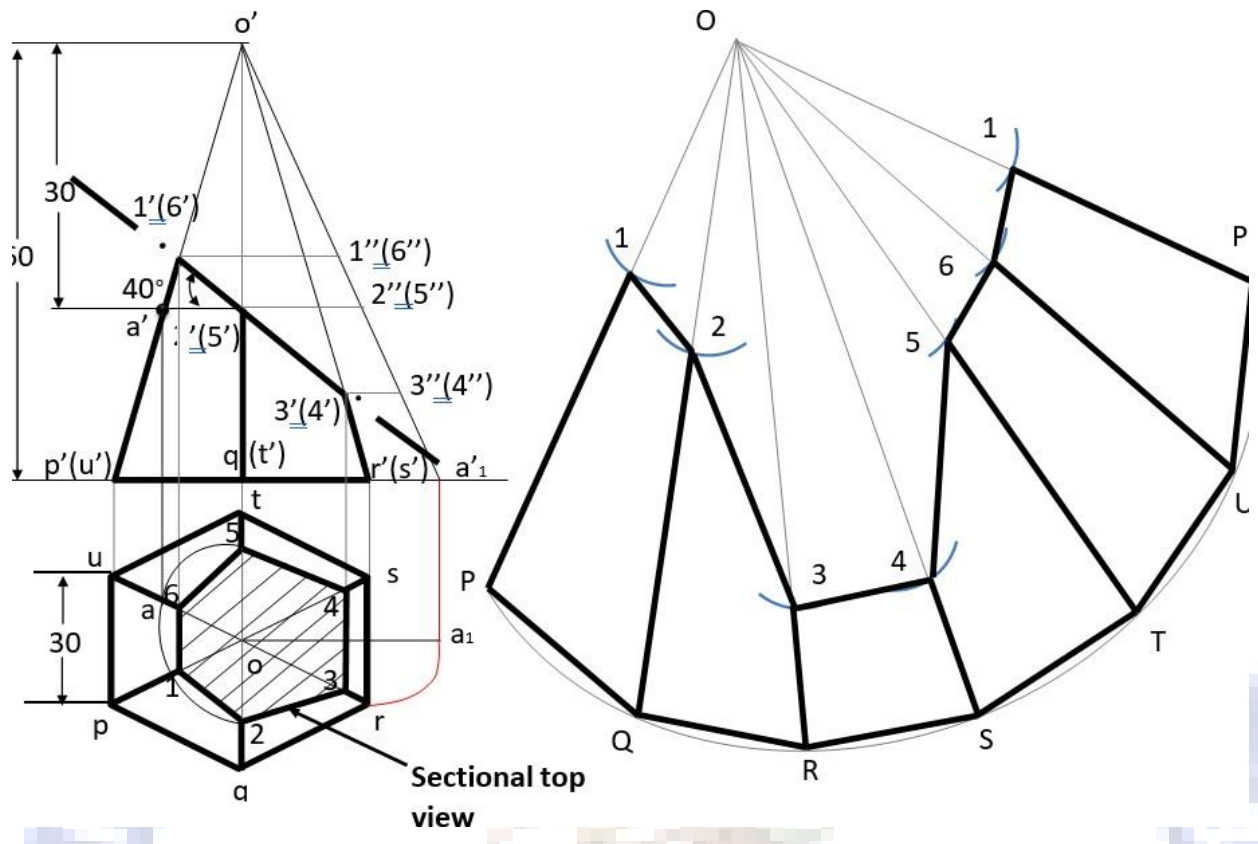

Figure 4.12

A **hexagonal pyramid** of base of side 25 mm and altitude 50 mm is resting vertically on its base on the ground with two of the sides of the base perpendicular to the VP. It is cut by a plane perpendicular to the VP and inclined at 40° to the HP, The plane bisects the axis of the pyramid. Draw the development of the lateral surfaces of the pyramid

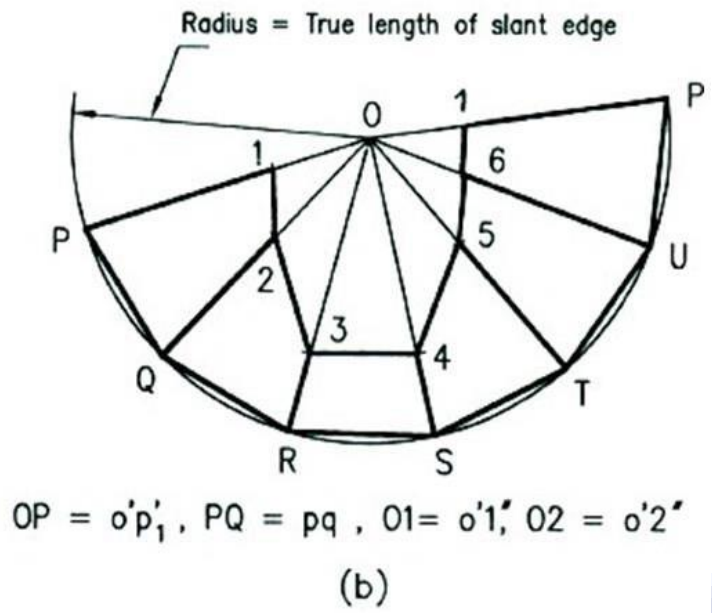
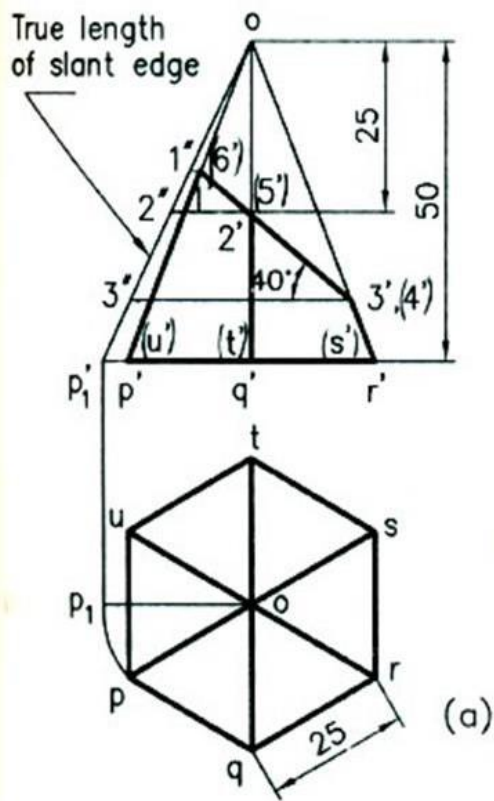
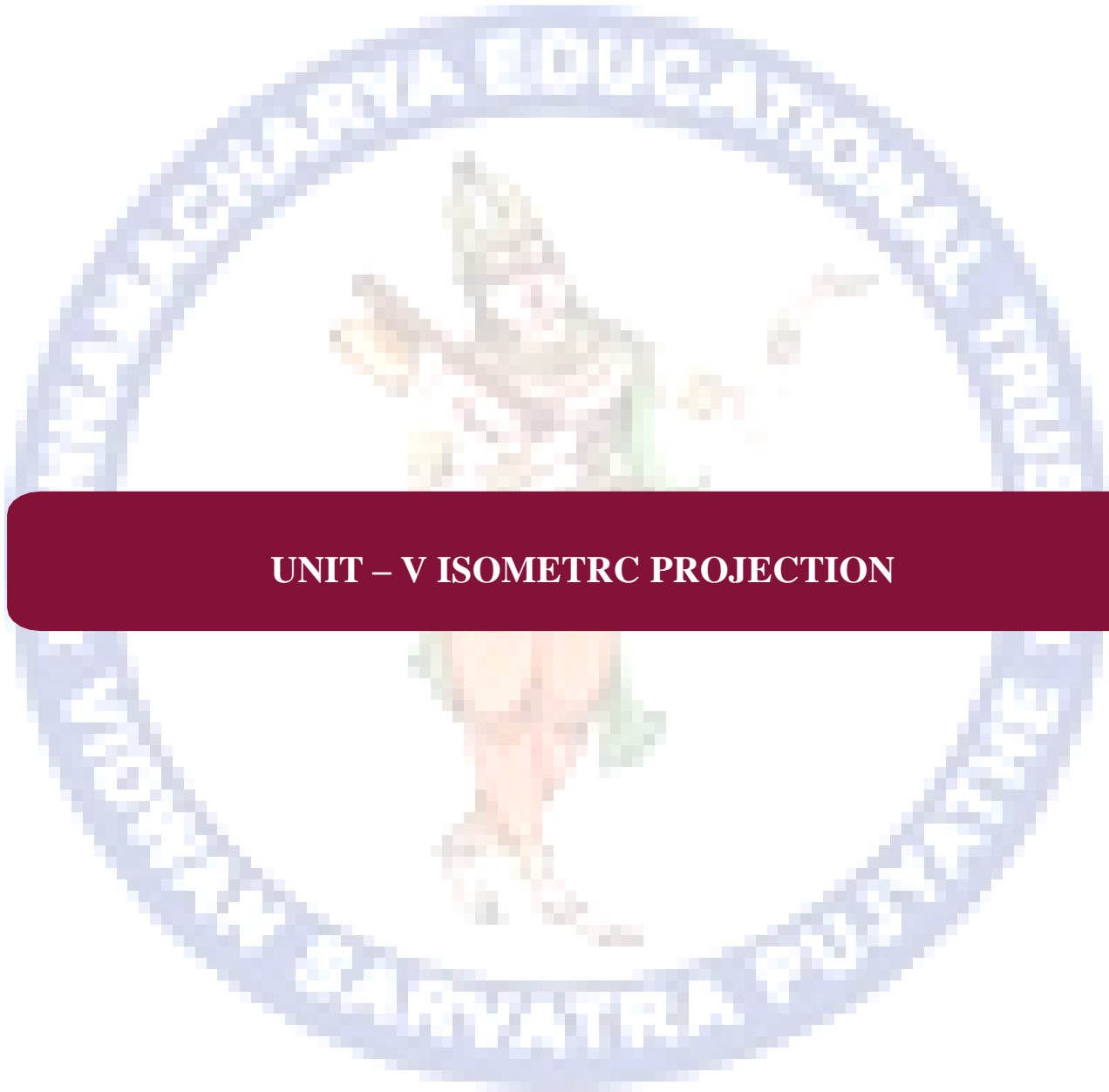

Figure 4.13



UNIT – V ISOMETRIC PROJECTION

Isometric Projection

Isometric projection

Isometric projection is a type of pictorial projection in which the three dimensions of a solid are not only shown in one view but their actual sizes can be measured directly from it.

Suppose the three lines PQ, PR and PS, meeting at point P and making 120° angles with each other are termed **Isometric Axes**.

The lines parallel to these axes are called **Isometric Lines**.

The planes representing the faces of the cube as well as other planes parallel to these planes are called **Isometric Planes**.

Isometric scale:

To draw isometric projection, it is necessary to convert true lengths into isometric lengths for measuring and marking the sizes.

Isometric view



true length

Isometric Projection



Reduced length

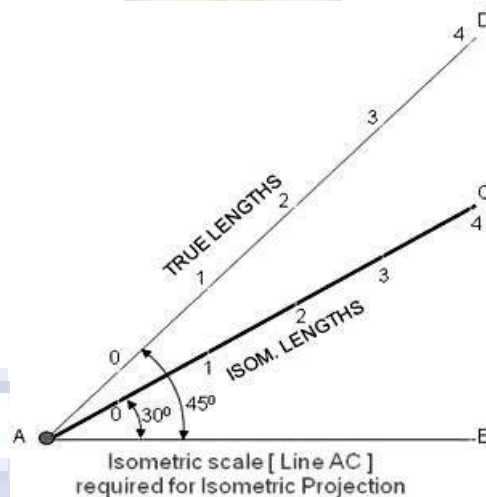

Figure 5.1

The general steps in the box technique are:

1. Define the origin of and create the isometric axes.
2. Create the bounding box using the principal dimensions.
3. Use dimensions from top and front view to mark out faces.
4. Or use dimensions from top and side views to mark out faces.
5. Locate and create all features on the faces.
6. Finish and check the drawing.

Definitions:

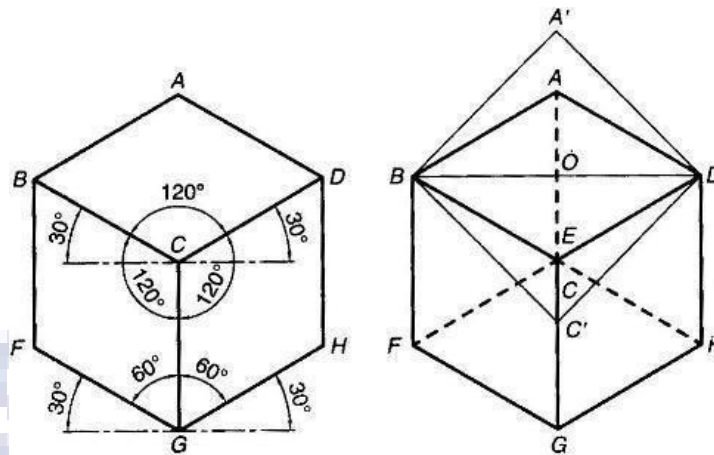

Figure 5.2

Isometric axes: The Three Lines CB, CD, CG meeting at a point C and making an angle of 120° with each other are called Isometric axes.

Isometric Lines: The Lines parallel to the Isometric Axis are termed as Isometric lines. Example from above fig. AB, AD, GF, GH, BF, DH are Isometric Lines.

Non-Isometric Lines: The lines which are not parallel to the isometric axes are known as Non- Isometric Lines Example from above fig. BD, AC, CF, BG are Non-Isometric Lines.

Isometric Planes: The planes representing the faces of the cube as well as other planes parallel to these planes are termed as Isometric Planes Example from above fig. ABCD, BCGF, CGHD are Isometric Planes

Isometric Scale: It is the scale which is used to convert the true length in to Isometric Length

Problem 1.

Draw the isometric view of a square with 40mm side?

Solution:

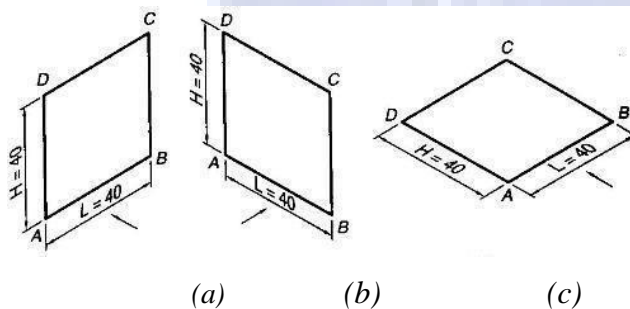
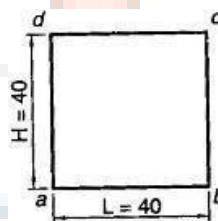

Figure 5.3

Problem 2.

Draw the isometric view of a Hexagon with 40mm side such that its surface is Parallel to the HP and a side Parallel to the VP?

Solution:

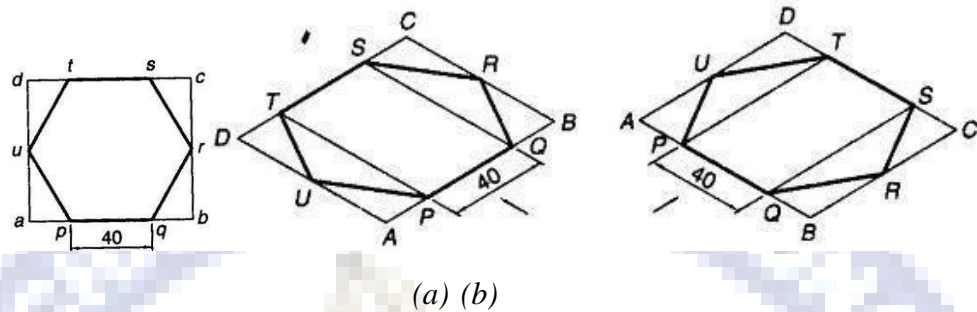

Figure 5.4

Problem 3:

Draw the isometric view of a Circle with a 60mm Diameter on all three Principle Planes Using Co- ordinate methods?

Solution:

Construction Procedure:

1. Draw a circle with 60mm Diameter and enclose it in a square abcd.
2. Mark midpoints of the sides 1, 2, 3 and 4, where the square touches the circle tangentially
3. Draw the Diagonals of the square which cut in the circle at points 5, 6, 7 and 8 as shown in fig (a).
4. Draw a Rhombus ABCD to represent Isometric view of a square abcd.
5. Mark points 1, 2, 3 and 4 on it as the midpoint of the sides.
6. Mark points 5, 6, 7 and 8 on it, such that they are at a distance equal to ax from the side of the square .join points to obtain isometric view as shown in figures b,c,d.

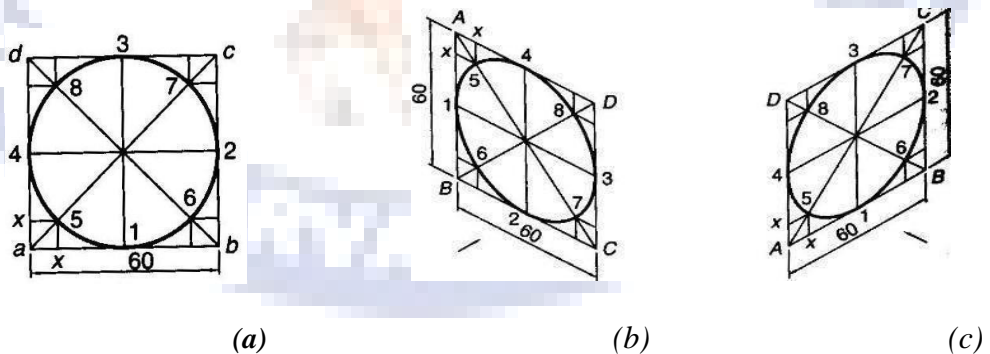

(a)

(b)

(c)

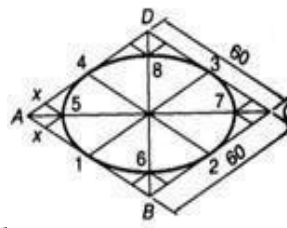

(d,

Figure 5.5

Problem 4:

Draw the isometric view of a Circle lamina with a 60mm Diameter on all three Principle Planes using for center methods?

Solution:

Construction:

1. **Draw a Rhombus ABCD of 60mm side to represent isometric view of a square**
2. Mark 1,2,3 and 4 as a midpoints of the sides AB,BC,CD and DA respectively join (the ends of the minor diagonals) B to meet points 3 & 4 and D to meet points 1 & 2. Let B4 and D1 intersect at point E and B3 and D2 intersect at a point F. then B,E,D and F are the Four centers for drawing the ellipse
3. With center B and radius B3 draw Arc 3-4. With center D and Radius D1 draw Arc 1-2. With center E and radius E1 draw Arc 1-4. With centre F and radius F2 draw Arc 2-3.
4. These Arcs join in the form of an Ellipse which represents the required isometric as shown in figure (a)(b)(c)

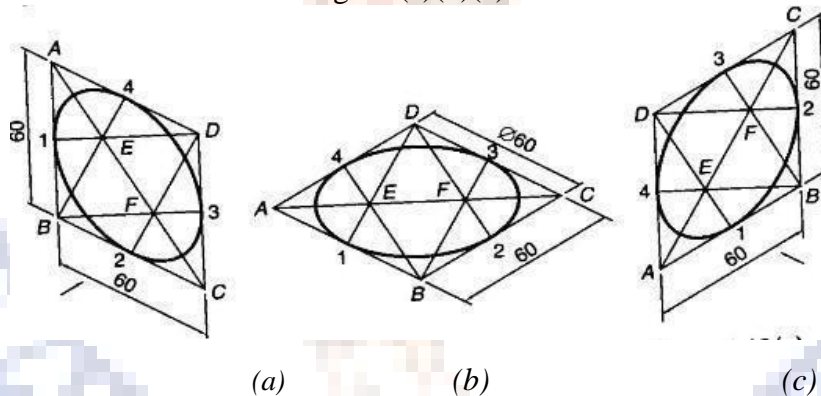

Figure 5.6

Isometric views of solids

Problem 5

Problem:

Draw isometric view of a hexagonal prism having a base with 30 mm side and a 70mm long axis resting on its base on the HP. With an edge of the base parallel to the VP when (a) using Box Methods (b) using Off-set Method.

Solution:

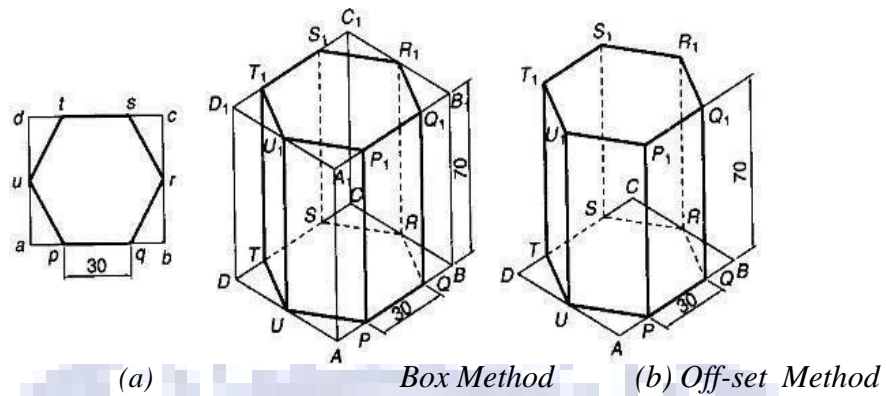

Figure 5.8

Problem:

Draw an isometric view of a cylinder, with a 50mm base diameter and a 70mm long axis when

- (a) The base is on the HP (b) when one of the generators is on the HP?

Solution:

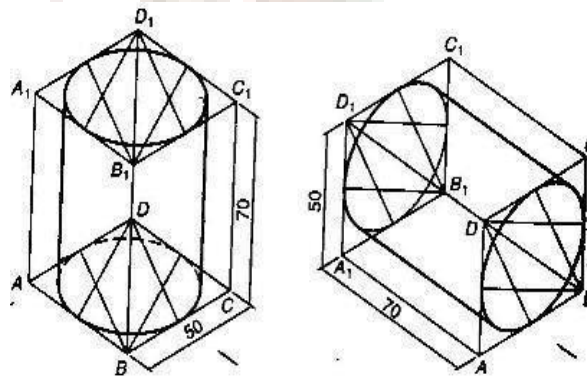
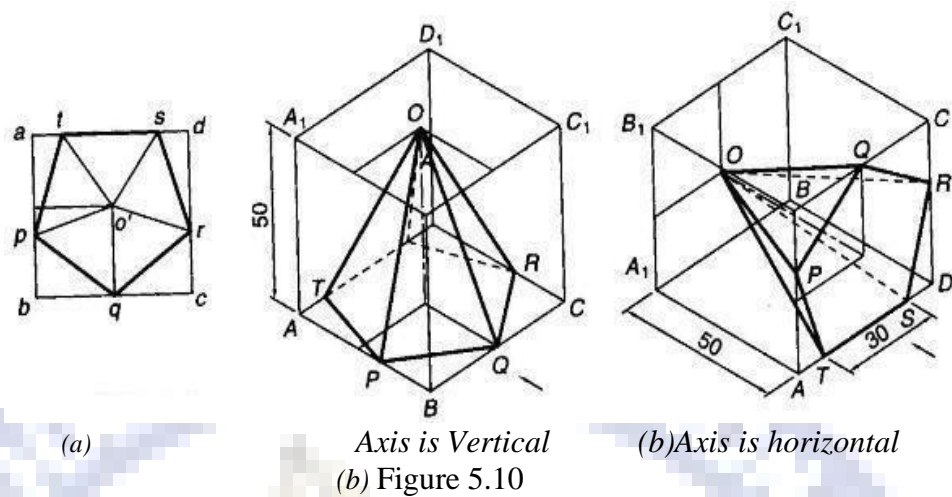

Figure 5.9

Problem:

Draw an isometric view of a pentagonal pyramid having a base, with a 30 mm side and 50mm long axis (a) when the its axis is vertical (b) when the its axis is horizontal?

Solution:



Problem:

Draw an isometric view of Cone with a base diameter is 50 mm side and 70mm long axis (a) when the base is on the HP (b) when the base is on the VP?

Solution:

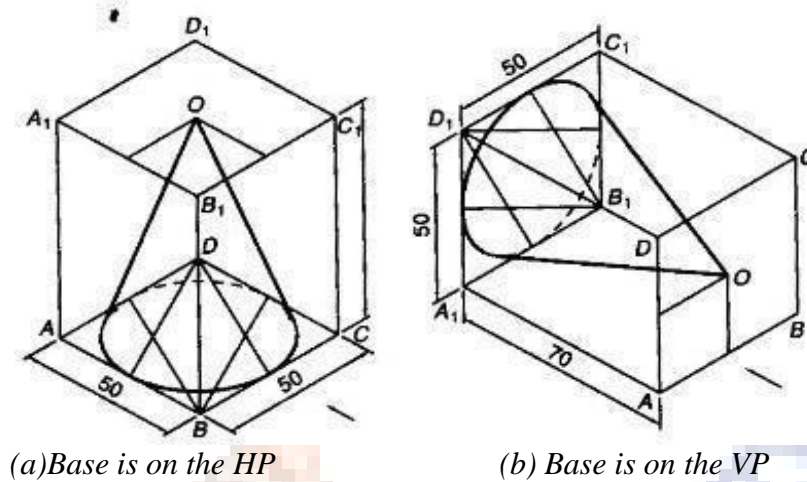

Isometric View of Composite Solids

Problem:

A Sphere with a 60 mm diameter is resting centrally on the Top of the Square Block with a 70 mm side 20 mm thickness. Draw an isometric view of the arrangement?

Solution:

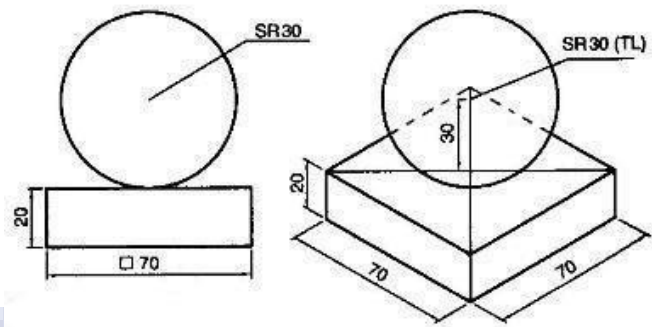
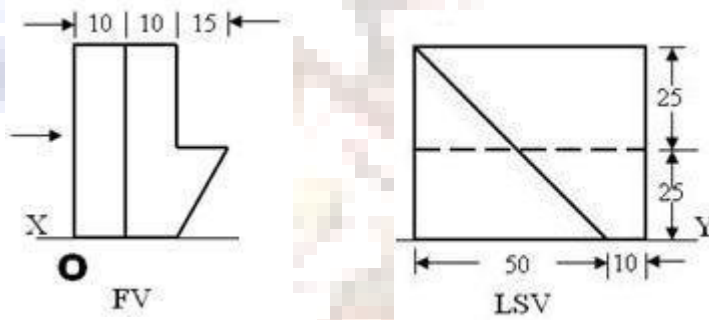

Figure 5.12

Problem:

Draw the isometric view of the given orthographic projection of the object?



Solution:

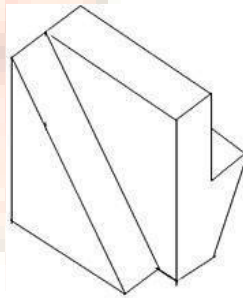
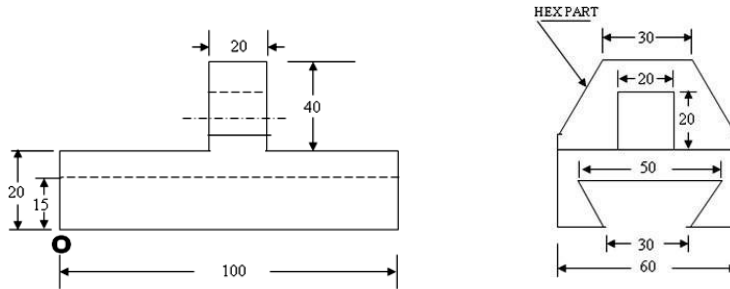

Figure 5.13

Problem:

Draw the isometric view of the given orthographic projection of the object?



Solution:

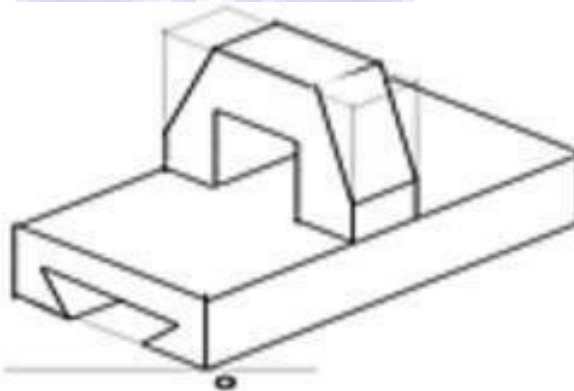

Figure 5.13

Orthographic Projection

When the Projectors are parallel to each other and also perpendicular to the plane the projection is called orthographic Projection

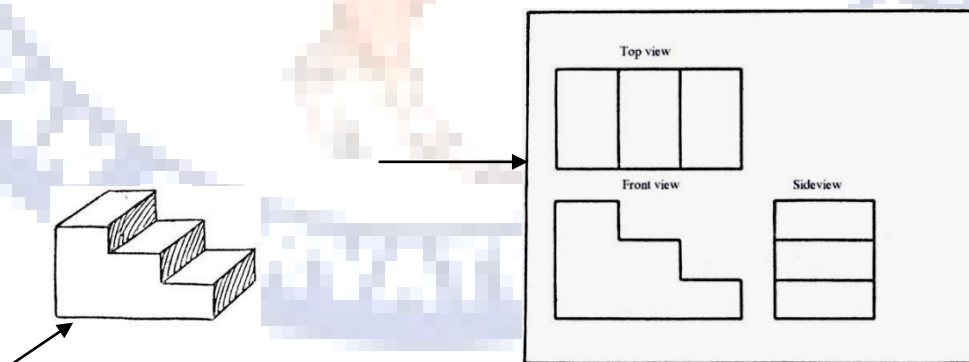

Figure 5.14

Problem:

Draw the front view, Top view and Side view of the given figure?

Problems:

Draw the front view, Top view and Side view of the given figure?

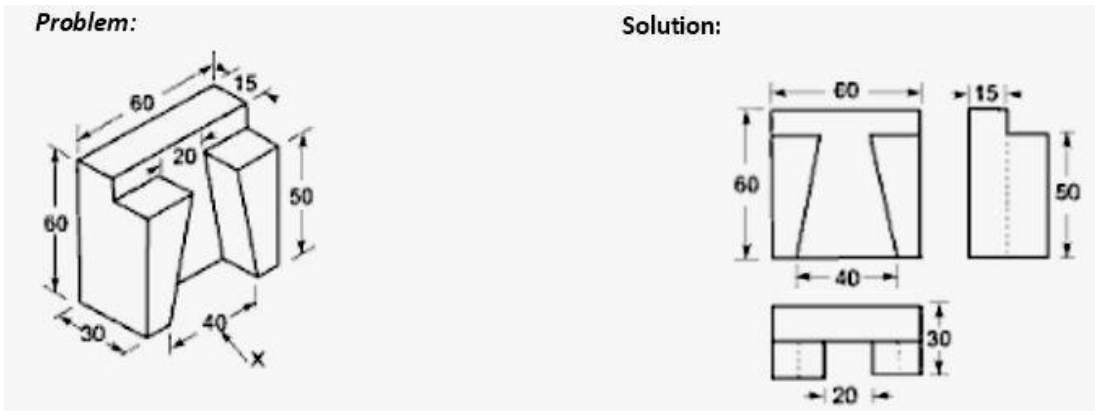

Figure 5.15

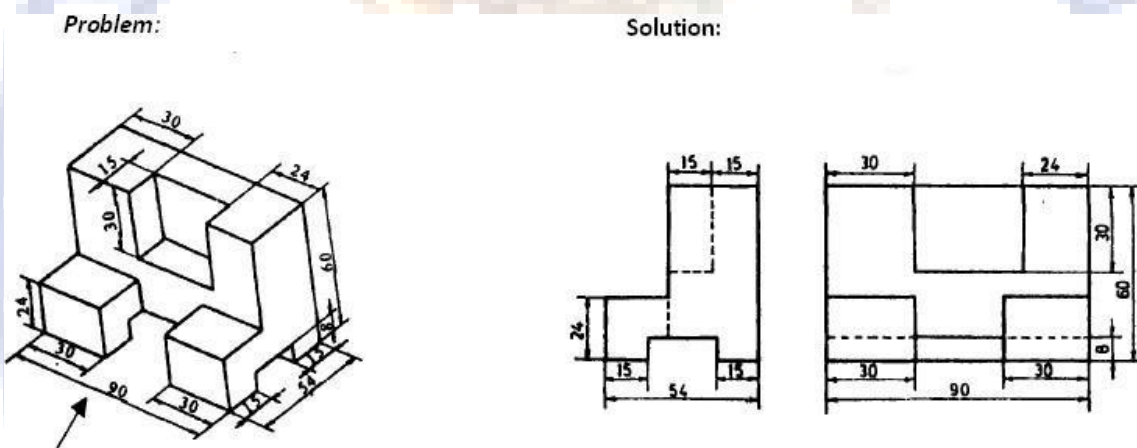

Figure 5.16

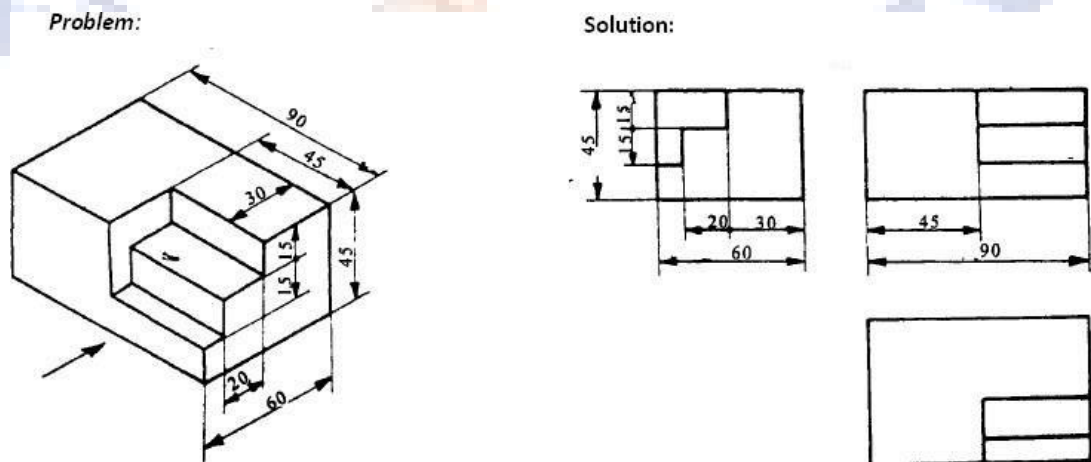
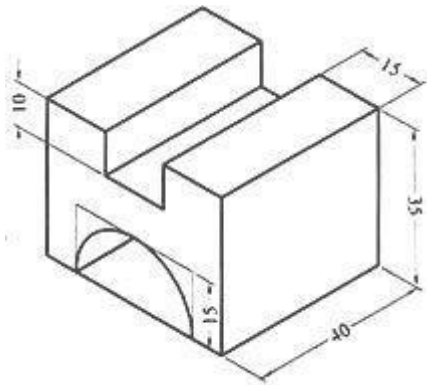

Figure 5.17

Problem



isometric view

Solution

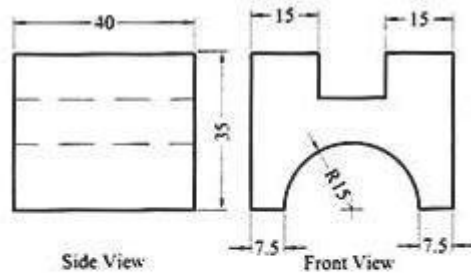

Side View

Front View

Top View

Figure 5.18

Problem:

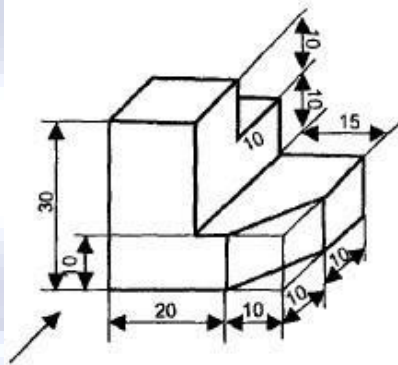

Solution:

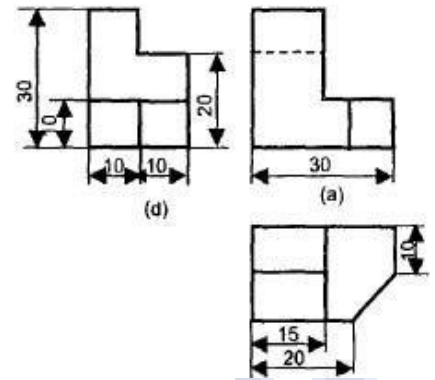
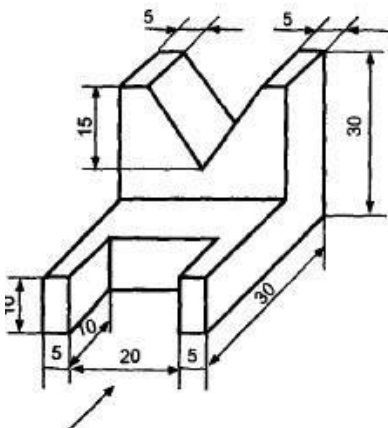

Figure 5.19

Problem:



Solution:

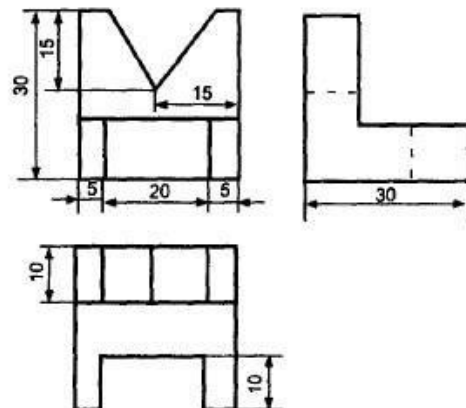
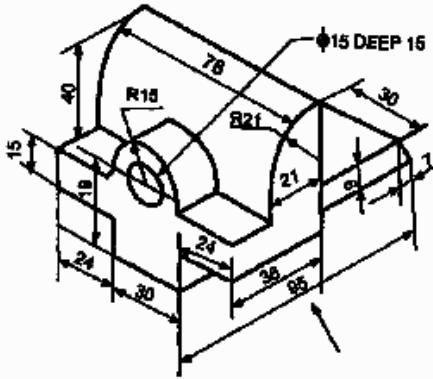

Figure 5.20

Problem:



Solution:

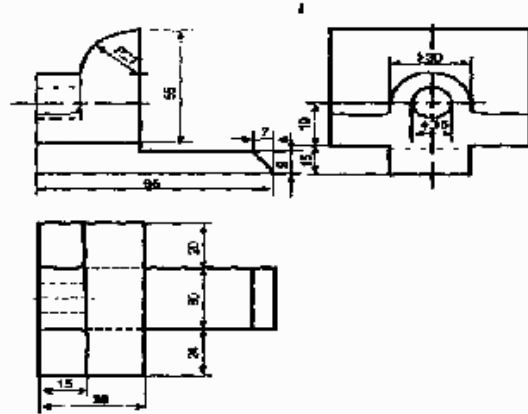
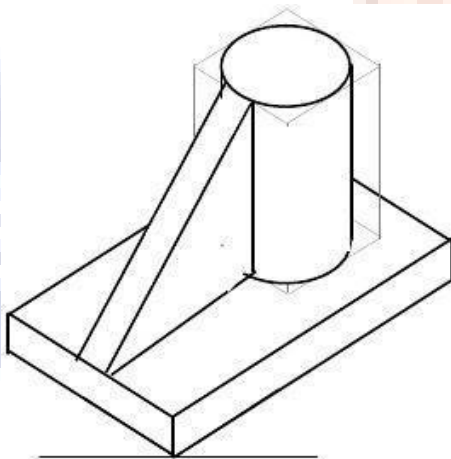

Figure 5.21

Problem:



Solution:

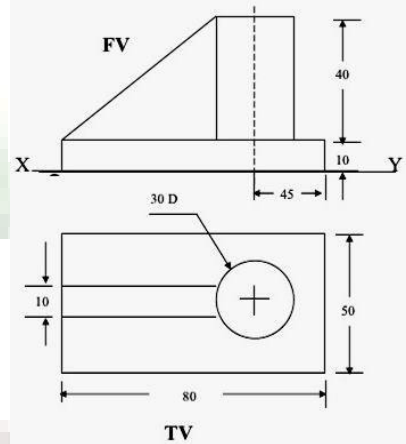

Figure 5.22