

**ANNAMACHARYA INSTITUTE OF TECHNOLOGY AND SCIENCES, TIRUPATI  
(AUTONOMOUS)  
ELECTRONICS AND COMMUNICATION ENGINEERING (ECE)  
AK 23 REGULATIONS**

Course Code	Year & Sem	<b>VLSI DESIGN</b>	L	T/CLC	P	C
23APC0417	III-II		2	1	0	3

**Course Outcomes:** Students should be able to

**CO1: Understand** the steps involved in the fabrication of ICs using MOS transistor technology.

**CO2: Analyze** the VLSI design processes, stick diagrams, and layouts with design rules.

**CO3: Analyze** knowledge of gate-level design concepts like Logic gates, complex gates and Switch logic.

**CO4: Analyze** various subsystems using different VLSI design styles and methods.

**CO5: Evaluate** CMOS testing and testability techniques for integrated circuits.

CO	Action Verb	Knowledge Statement	Condition	Criteria	Blooms level
CO1	Understand	the steps involved in the fabrication	of ICs using MOS transistor technology		L2
CO2	Analyze	the VLSI design processes,	stick diagrams and layouts		L4
CO3	Analyze	knowledge of gate-level design concepts	Logic gates, complex gates and Switch logic.		L4
CO4	Analyze	Various subsystems using	different VLSI design styles.		L4
CO5	Evaluate	CMOS testing and testability techniques	for integrated circuits		L5

<b>UNIT - I</b>	20Hrs
Introduction: Brief Introduction to IC technology MOS, PMOS, NMOS, CMOS & BiCMOS Technologies. Basic Electrical Properties of MOS and BiCMOS Circuits: IDS - VDS relationships, MOS transistor Threshold Voltage, figure of merit, Transconductance, Pass transistor, NMOS Inverter, Various pull ups, CMOS Inverter analysis and design, Bi-CMOS Inverters	
<b>UNIT - II</b>	21Hrs
VLSI Circuit Design Processes: VLSI Design Flow, MOS Layers, Stick Diagrams, Design Rules and Layout, Lambda( $\lambda$ )-based design rules for wires, contacts and Transistors, Layout Diagrams for NMOS and CMOS Inverters and Gates, Scaling of MOS circuits, Limitations of Scaling.	
<b>UNIT - III</b>	10Hrs
Gate level Design: Logic gates and other complex gates, Switch logic, Alternate gate circuits. Basic Circuit Concepts: Sheet Resistance $R_s$ and its concepts to MOS, Area Capacitances calculations, Inverter Delays, Driving large Capacitive Loads, Wiring Capacitances, Fan-in and fan-out	
<b>UNIT - IV</b>	10Hrs
Subsystem Design: Shifters, Adders, ALUs, Multipliers, Parity generators, Comparators, Counters. VLSI Design styles: Full-custom, Standard Cells, Gate-arrays, FPGAs, CPLDs and Design Approach for Full-custom and Semi-custom devices, parameters influencing low power design	
<b>UNIT - V</b>	11Hrs
CMOS Testing: Need for testing, Design for testability - built in self-test (BIST) - testing combinational logic -testing sequential logic - practical design for test guide lines - scan design techniques	
<b>Textbooks:</b>	
1. Essentials of VLSI Circuits and Systems, Kamran Eshraghian, Eshraghian Douglas, A. Pucknell, 2005, PHI.	
2. Modern VLSI Design - Wayne Wolf, 3 Ed., 1997, Pearson Education	
<b>Reference Books:</b>	
1. CMOS VLSI Design-A Circuits and Systems Perspective, Neil H.E Weste, David Harris, Ayan Banerjee, 3rd Edn, Pearson, 2009.	
2. Behzad Razavi, -Design of Analog CMOS Integrated Circuits  , McGraw Hill, 2003.	

**Mapping of course outcomes with program outcomes**

CO	PO1	PO2	PO3	PO4	PO5	PO6	PO7	PO8	PO9	PO10	PO11	PSO1	PSO2
CO1	2	3									1	2	
CO2		3		1							1	2	
CO3			1	2							1	1	
CO4			1	2							1	1	
CO5				3	2						1	1	2

**Correlation matrix**

Unit No.	CO					Program Outcome (PO)	PO(s) :Action Verb and BTL(for PO1 to PO11)	Level of Correlation (0-3)
	Lesson plan(Hrs)	%	Correlation	Co's Action verb	BTL			
1	20	27.78	3	Understand	L2	PO1, PO2, PO11	PO1: Apply (L3) PO2: Review (L2) PO11: Thumb rule	2 3 1
2	21	29.16	3	Analyze	L4	PO2, PO4, PO11	PO2: Analyze (L4) PO4: Interpret(L2) PO11: Thumb rule	3 3 1
3	10	13.88	2	Analyze	L4	PO3, PO4, PO11	PO3: Design (L6) PO4: Interpret (L5) PO11: Thumb rule	1 2 1
4	10	13.88	2	Analyze	L4	PO3, PO4, PO11	PO3: Design (L6) PO4: Interpret (L5) PO11: Thumb rule	1 2 1
5	11	15.3	2	Evaluate	L5	PO4, PO5, PO11	PO4: Interpret (L5) PO5: Create (L6) PO11: Thumb rule	3 2 1
	72	100						

**Justification Statements:**

**CO1: Understand** the steps involved in the fabrication of ICs using MOS transistor technology.

**Action Verb- Understand (L2)**

PO1: Action Verb- Apply (L3), CO1 action verb is less than PO1 action verb by one level, therefore correlation is moderate (2)

PO2: Action verb- Review (L2), CO1 action verb is equal to PO2 action verb, therefore correlation is high (3)

PO11: CO1 correlates PO11 as per thumb rule with correlation is Low (1)

**CO2: Analyze** the VLSI design processes, stick diagrams, and layouts with design rules.

**Action Verb- Analyze(L4)**

PO2: Action verb- Analyze (L4), CO2 action verb is equal to PO2 action verb; therefore correlation is high (3)

PO4: Action verb- Interpret(L2), CO2 action verb is greater than PO4 action verb; therefore correlation is high (3)

PO11: CO2 correlates PO11 as per thumb rule with correlation is Low (1)

**CO3: Analyze** knowledge of gate-level design concepts like Logic gates, complex gates and Switch logic.

**Action Verb- Analyze(L4)**

PO3: Action verb- Design (L6), CO3 action verb is less than to PO3 action verb by two levels; therefore correlation is Low (1)

PO4: Action verb- Interpret(L5), CO3 action verb is less than PO4 action verb by one level; therefore correlation is moderate (2)

PO11: CO3 correlates PO11 as per thumb rule with correlation is Low (1)

**CO4:Analyze** various subsystems using different VLSI design styles and methods.

**Action Verb- Analyze(L4)**

PO3: Action verb- CO4 action verb is less than to PO3 action verb by two levels; therefore correlation is Low (1)

PO4: Action verb- Interpret(L5), CO4 action verb is less than to PO3 action verb by two levels; therefore correlation is Low (1)

PO11: CO4 correlates PO11 as per thumb rule with correlation is Low (1)

**CO5: Evaluate** CMOS testing and testability techniques for integrated circuits.

**Action Verb- Evaluate (L5)**

PO4: Action verb- Interpret(L5), CO5 action verb is equal to PO4 action verb; therefore correlation is high (3)

PO5: Action verb- Create(L6), CO5 action verb is less than PO5 action verb by one; therefore correlation is moderate (2)

PO11: CO5 correlates PO11 as per thumb rule with correlation is Low (1)

## **INTRODUCTION TO IC TECHNOLOGY**

The development of electronics endless with invention of vacuum tubes and associated electronic circuits. This activity termed as vacuum tube electronics, afterward the evolution of solid state devices and consequent development of integrated circuits are responsible for the present status of communication, computing and instrumentation.

- The first vacuum tube diode was invented by **John Ambrose Fleming** in 1904.
- The vacuum triode was invented by **Lee de Forest** in 1906.

Early developments of the Integrated Circuit (IC) go back to 1949. German engineer Werner Jacobi filed a patent for an IC like semiconductor amplifying device showing five transistors on a common substrate in a 2-stage amplifier arrangement. Jacobi disclosed small cheap of hearing aids.

Integrated circuits were made possible by experimental discoveries which showed that semiconductor devices could perform the functions of vacuum tubes and by mid-20th-century technology advancements in semiconductor device fabrication.

The integration of large numbers of tiny transistors into a small chip was an enormous improvement over the manual assembly of circuits using electronic components.

The integrated circuits mass production capability, reliability, and building-block approach to circuit design ensured the rapid adoption of standardized ICs in place of designs using discrete transistors.

**An integrated circuit (IC) is a small semiconductor-based electronic device consisting of fabricated transistors, resistors and capacitors. Integrated circuits are the building blocks of most electronic devices and equipment. An integrated circuit is also known as a chip or microchip.**

There are two main advantages of ICs over discrete circuits: cost and performance. Cost is low because the chips, with all their components, are printed as a unit by photolithography rather than being constructed one transistor at a time. Furthermore, much less material is used to construct a packaged IC die than a discrete circuit. Performance is high since the components switch quickly and consume little power (compared to their discrete counterparts) because the components are small and positioned close together. As of 2006, chip areas range from a few square millimeters to around 350 mm<sup>2</sup>, with up to 1 million transistors per mm

**IC Invention:**

<b>Inventor</b>	<b>Year</b>	<b>Circuit</b>	<b>Remark</b>
<b>Fleming</b>	<b>1904</b>	<b>Vacuum tube diode</b>	<b>large expensive, power-hungry, unreliable</b>
	<b>1906</b>	<b>Vacuum triode</b>	
<b>William Shockley (Bell labs)</b>	<b>1945</b>	<b>Semiconductor replacing vacuum tube</b>	--
<b>Bardeen and Brattain and Shockley (Bell labs)</b>	<b>1947</b>	<b>Point Contact transfer resistance device "BJT"</b>	<b>Driving factor of growth of the VLSI technology</b>
<b>Werner Jacobi (Siemens AG)</b>	<b>1949</b>	<b>1<sup>st</sup> IC containing amplifying Device 2stage amplifier</b>	<b>No commercial use reported</b>
<b>Shockley</b>	<b>1951</b>	<b>Junction Transistor</b>	<b>"Practical form of transistor"</b>
<b>Jack Kilby (Texas Instruments)</b>	<b>July 1958</b>	<b>Integrated Circuits F/F With 2-T Germanium slice and gold wires</b>	<b>Father of IC design</b>
<b>Noyce Fairchild Semiconductor</b>	<b>Dec. 1958</b>	<b>Integrated Circuits Silicon</b>	<b>"The Mayor of Silicon Valley"</b>
<b>Kahng Bell Lab</b>	<b>1960</b>	<b>First MOSFET</b>	<b>Start of new era for semiconductor industry</b>
<b>Fairchild Semiconductor And Texas</b>	<b>1061</b>	<b>First Commercial IC</b>	
<b>Frank Wanlass (Fairchild Semiconductor)</b>	<b>1963</b>	<b>CMOS</b>	
<b>Federico Faggin (Fairchild Semiconductor)</b>	<b>1968</b>	<b>Silicon gate IC technology</b>	<b>Later Joined Intel to lead first CPU Intel 4004 in 1970</b> <b>2300 T on 9mm<sup>2</sup></b>
<b>Zarlink Semiconductors</b>	<b>Recently</b>	<b>M2A capsule for endoscopy</b>	<b>take photographs of digestive tract 2/sec.</b>

**Moore’s Law:**

- Gordon E. Moore - Chairman Emeritus of Intel Corporation
- 1965 - observed trends in industry - of transistors on ICs vs release dates
- Noticed number of transistors doubling with release of each new IC generation
- Release dates (separate generations) were all 18-24 months apart

**“The number of transistors on an integrated circuit will double every 18 months”**

The level of integration of silicon technology as measured in terms of number of devices per IC Semiconductor industry has followed this prediction with surprising accuracy.

**IC Technology:**

- Speed / Power performance of available technologies
- The microelectronics evolution
- SIA Roadmap
- Semiconductor Manufacturers 2001 Ranking

**Circuit Technology**

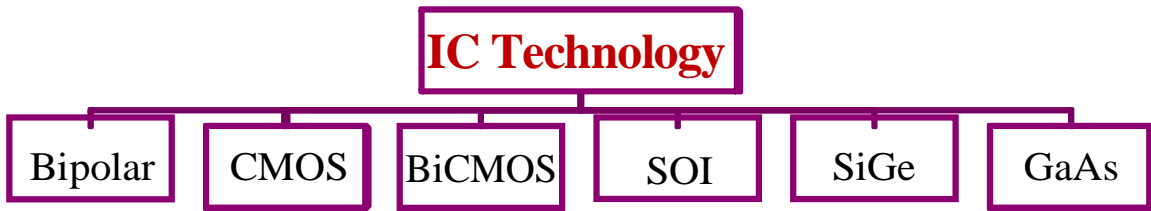

Category	BJT	CMOS
Power Dissipation	Moderate to High	less
Speed	Faster	Fast
Gm	4ms	0.4ms
Switch implementation	poor	Good
Technology improvement	slower	Faster

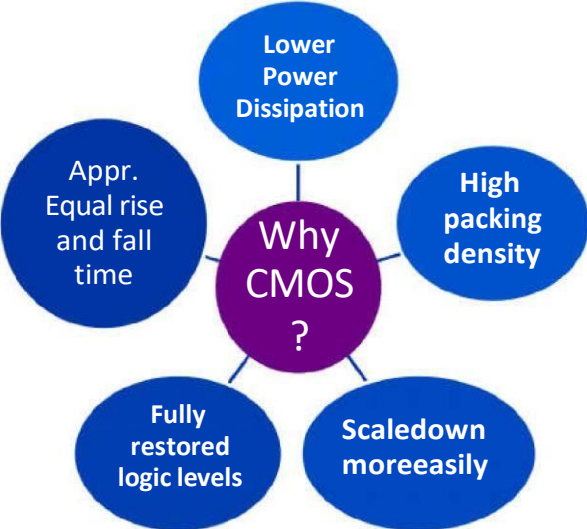

**Scale of Integration:**

- **Small scale integration(SSI) --1960**

The technology was developed by integrating the number of transistors of 1-100 on a single chip. Ex: Gates, flip-flops, op-amps.

- **Medium scale integration(MSI) --1967**

The technology was developed by integrating the number of transistors of 100-1000 on a single chip. Ex: Counters, MUX, adders, 4-bit microprocessors.

- **Large scale integration(LSI) --1972**

The technology was developed by integrating the number of transistors of 1000-10000 on a single chip. Ex: 8-bit microprocessors, ROM, RAM.

- **Very large scale integration(VLSI) -1978**

The technology was developed by integrating the number of transistors of 10000-1 Million on a single chip. Ex: 16-32 bit microprocessors, peripherals, complimentary high MOS.

- **Ultra large scale integration(ULSI)**

The technology was developed by integrating the number of transistors of 1 Million-10 Millions on a single chip. Ex: special purpose processors.

- **Giant scale integration(GSI)**

The technology was developed by integrating the number of transistors of above 10 Millions on a single chip. Ex: Embedded system, system on chip.

- ✓ Fabrication technology has advanced to the point that we can put a complete system on a single chip.
- ✓ Single chip computer can include a CPU, bus, I/O devices and memory.
- ✓ This reduces the manufacturing cost than the equivalent board level system with higher performance and lower power.

**MOS TECHNOLOGY:**

MOS technology is considered as one of the very important and promising technologies in the VLSI design process. The circuit designs are realized based on pMOS, nMOS, CMOS and BiCMOS devices.

The pMOS devices are based on the p-channel MOS transistors. Specifically, the pMOS channel is part of a n-type substrate lying between two heavily doped p+ wells beneath the source and drain electrodes. Generally speaking, a pMOS transistor is only constructed in consort with an NMOS transistor.

The nMOS technology and design processes provide an excellent background for other technologies. In particular, some familiarity with nMOS allows a relatively easy transition to CMOS technology and design.

The techniques employed in nMOS technology for logic design are similar to GaAs technology.. Therefore, understanding the basics of nMOS design will help in the layout of GaAs circuits

In addition to VLSI technology, the VLSI design processes also provides a new degree of freedom for designers which helps for the significant developments. With the rapid advances in technology the the size of the ICs is shrinking and the integration density is increasing.

The minimum line width of commercial products over the years is shown in the graph below.

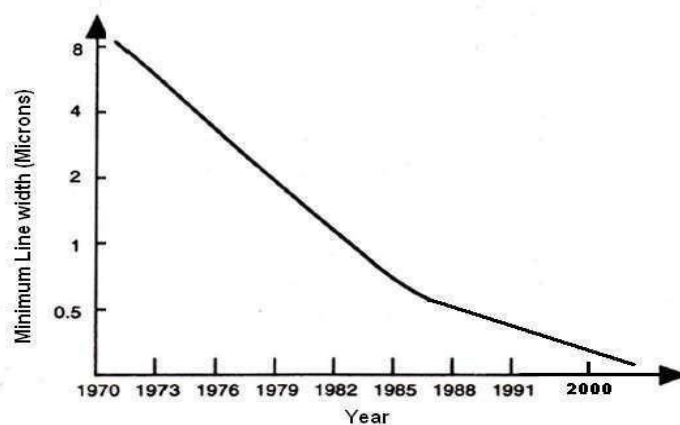

The graph shows a significant decrease in the size of the chip in recent years which implicitly indicates the advancements in the VLSI technology.

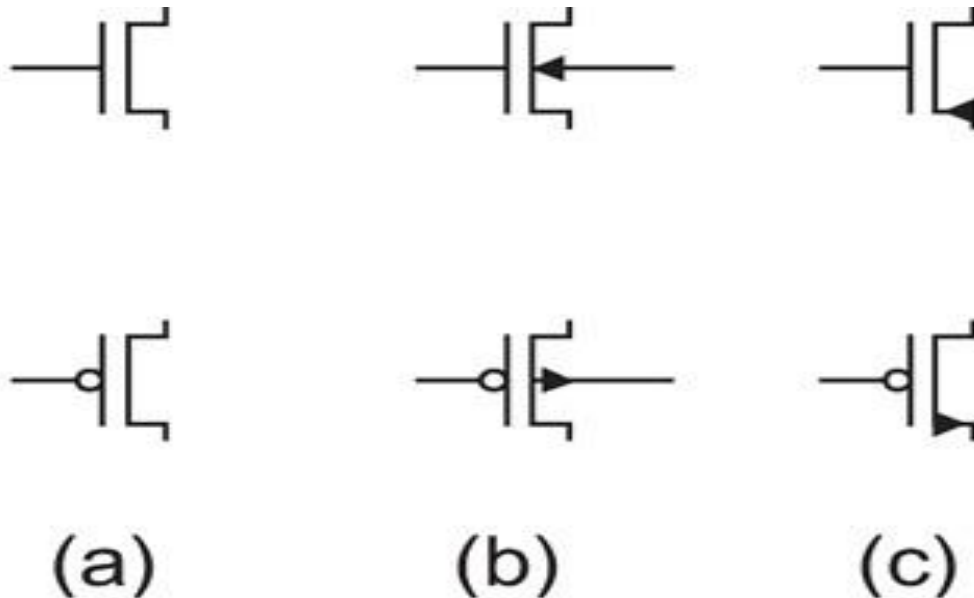
**MOS Transistor Symbol:****FIG 2.1****MOS transistor symbols****ENHANCEMENT AND DEPLETION MODE MOS TRANSISTORS**

MOS Transistors are built on a silicon substrate. Silicon which is a group IV material is the eighth most common element in the universe by mass, but very rarely occurs as the pure free element in nature. It is most widely distributed in dusts, sands, planetoids, and planets as various forms of silicon dioxide (silica) or silicates. It forms crystal lattice with bonds to four neighbours. Silicon is a semiconductor. Pure silicon has no free carriers and conducts poorly. But adding dopants to silicon increases its conductivity. If a group V material i.e. an extra electron is added, it forms an n-type semiconductor. If a group III material i.e. missing electron pattern is formed (hole), the resulting semiconductor is called a p-type semiconductor.

A junction between p-type and n-type semiconductor forms a conduction path. Source and Drain of the Metal Oxide Semiconductor (MOS) Transistor is formed by the “doped” regions on the

surface of chip. Oxide layer is formed by means of deposition of the silicon dioxide ( $\text{SiO}_2$ ) layer which forms as an insulator and is a very thin pattern. Gate of the MOS transistor is the thin layer of “polysilicon (poly)”; used to apply electric field to the surface of silicon between Drain and Source, to form a “channel” of electrons or holes. Control by the Gate voltage is achieved by modulating the conductivity of the semiconductor region just below the gate. This region is known as the channel.

The Metal–Oxide–Semiconductor Field Effect Transistor (MOSFET) is a transistor which is a voltage-controlled current device, in which current at two electrodes, drain and source is controlled by the action of an electric field at another electrode gate having in-between semiconductor and a very thin metal oxide layer. It is used for amplifying or switching electronic signals.

The Enhancement and Depletion mode MOS transistors are further classified as N-type named NMOS (or N-channel MOS) and P-type named PMOS (or P-channel MOS) devices. Figure 1.5 shows the MOSFETs along with their enhancement and depletion modes.

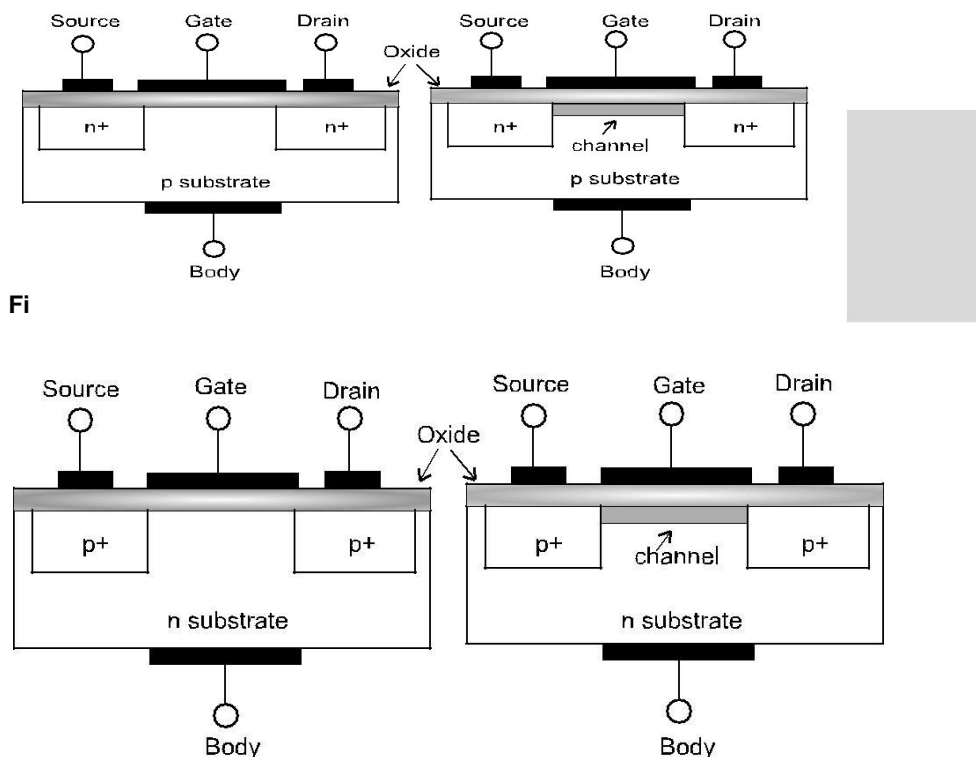

**Figure 1.5:** (c) Enhancement P-type MOSFET (d) Depletion P-type MOSFET

The depletion mode devices are doped so that a channel exists even with zero voltage from gate to source during manufacturing of the device. Hence the channel always appears in the device. To control the channel, a negative voltage is applied to the gate (for an N-channel device), depleting the

channel, which reduces the current flow through the device. In essence, the depletion-mode device is equivalent to a closed (ON) switch, while the enhancement-mode device does not have the built in channel and is equivalent to an open (OFF) switch. Due to the difficulty of turning off the depletion mode devices, they are rarely used

### Working of Enhancement Mode Transistor

The enhancement mode devices do not have the in-built channel. By applying the required potentials, the channel can be formed. Also for the MOS devices, there is a threshold voltage ( $V_t$ ), below which not enough charges will be attracted for the channel to be formed. This threshold voltage for a MOS transistor is a function of doping levels and thickness of the oxide layer.

#### Case 1: $V_{gs} = 0V$ and $V_{gs} < V_t$

The device is non-conducting, when no gate voltage is applied ( $V_{gs} = 0V$ ) or ( $V_{gs} < V_t$ ) and also drain to source potential  $V_{ds} = 0$ . With an insufficient voltage on the gate to establish the channel region as N-type, there will be no conduction between the source and drain. Since there is no conducting channel, there is no current drawn, i.e.  $I_{ds} = 0$ , and the device is said to be in the **cut-off region**. This is shown in the Figure 1.7 (a).

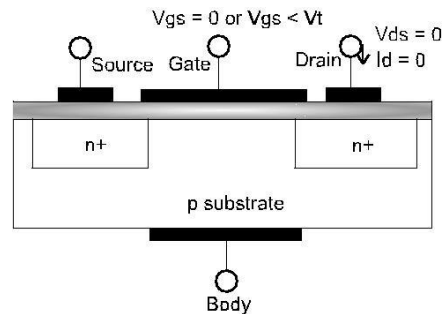

Figure 1.7: (a) Cut-off Region

#### Case 2: $V_{gs} > V_t$

When a minimum voltage greater than the threshold voltage  $V_t$  (i.e.  $V_{gs} > V_t$ ) is applied, a high concentration of negative charge carriers forms an inversion layer located by a thin layer next to the interface between the semiconductor and the oxide insulator. This forms a channel between the source and drain of the transistor. This is shown in the Figure 1.7 (b).

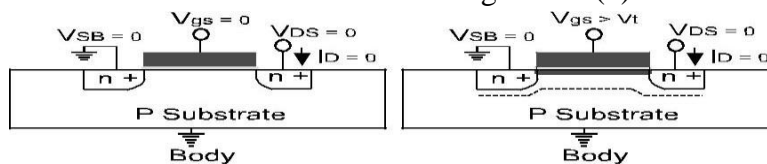

Figure 1.7: (b) Formation of a Channel

A positive  $V_{ds}$  reverse biases the drain substrate junction, hence the depletion region around the drain widens, and since the drain is adjacent to the gate edge, the depletion region widens in the channel. This is shown in Figure 1.7 (c). This results in flow of electron from source to drain resulting in current  $I_{ds}$ . The device is said to operate in **linear region** during this phase. Further increase in  $V_{ds}$ , increases the reverse bias on the drain substrate junction in contact with the inversion layer which causes inversion layer density to decrease. This is shown in Figure 1.7 (d). The point at which the inversion layer density becomes very small (nearly zero) at the drain end is termed pinch-off. The value of  $V_{ds}$  at pinch-off is denoted as  $V_{ds,sat}$ . This is termed as **saturation region** for the MOS device. Diffusion current completes the path from source to drain in this case, causing the channel to exhibit a high resistance and behaves as a constant current source.

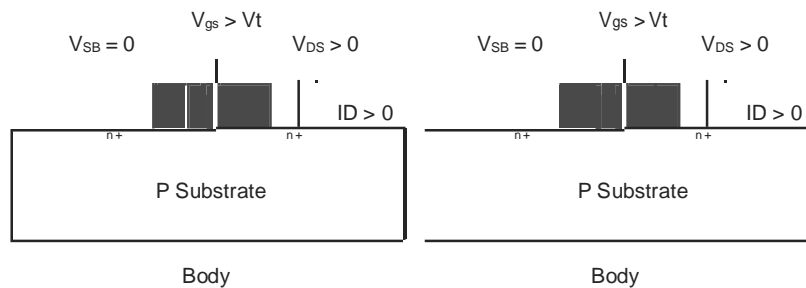

Figure 1.7: (c) Linear Region. (d) Saturation Region

The MOSFET  $I_D$  versus  $V_{DS}$  characteristics ( $V$ - $I$  Characteristics) is shown in the Figure 1.8. For  $V_{GS} < V_t$ ,  $I_D = 0$  and device is in cut-off region. As  $V_{DS}$  increases at a fixed  $V_{GS}$ ,  $I_D$  increases in the linear region due to the increased lateral field, but at a decreasing rate since the inversion layer density is decreasing. Once pinch-off is reached, further increase in  $V_{DS}$  results in increase in  $I_D$ ; due to the formation of the high field region which is very small. The device starts in linear region, and moves into saturation region at higher  $V_{DS}$ .

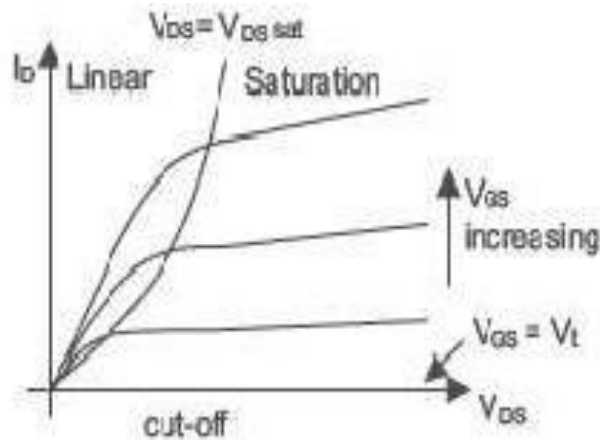

Figure 1.8: MOS  $V$ - $I$  Characteristics

## NMOS FABRICATION

The following description explains the basic steps used in the process of fabrication.

(a) The fabrication process starts with the oxidation of the silicon substrate.

It is shown in the Figure 1.9 (a).

(b) A relatively thick silicon dioxide layer, also called field oxide, is created on the surface of the substrate. This is shown in the Figure 1.9 (b).

(c) Then, the field oxide is selectively etched to expose the silicon surface on which the MOS transistor will be created. This is indicated in the Figure 1.9 (c).

(d) This is followed by covering the surface of substrate with a thin, high-quality oxide layer, which will eventually form the gate oxide of the MOS transistor as illustrated in Figure 1.9 (d).

(e) On top of the thin oxide, a layer of polysilicon (polycrystalline silicon) is deposited as is shown in the Figure 1.9 (e). Polysilicon is used both as gate electrode material for MOS transistors and also as an interconnect medium in silicon integrated circuits. Undoped polysilicon has relatively high resistivity. The resistivity of polysilicon can be reduced, however, by doping it with impurity atoms.

(f) After deposition, the polysilicon layer is patterned and etched to form the interconnects and the MOS transistor gates. This is shown in Figure 1.9 (f).

(g) The thin gate oxide not covered by polysilicon is also etched along, which exposes the bare silicon surface on which the source and drain junctions are to be formed (Figure 1.9 (g)).

(h) The entire silicon surface is then doped with high concentration of impurities, either through diffusion or ion implantation (in this case with donor atoms to produce n-type doping). Diffusion is achieved by heating the wafer to a high temperature and passing the gas containing desired impurities over the surface. Figure 1.9 (h) shows that the doping penetrates the exposed areas on the silicon surface, ultimately creating two n-type regions (source and drain junctions) in the p-type substrate. The impurity doping also penetrates the polysilicon on the surface, reducing its resistivity.

(i) Once the source and drain regions are completed, the entire surface is again covered with an insulating layer of silicon dioxide, as shown in

Figure 1.9 (i). (j) The insulating oxide layer is then patterned in order to provide contact windows for the drain and source junctions, as illustrated in Figure 1.9 (j).

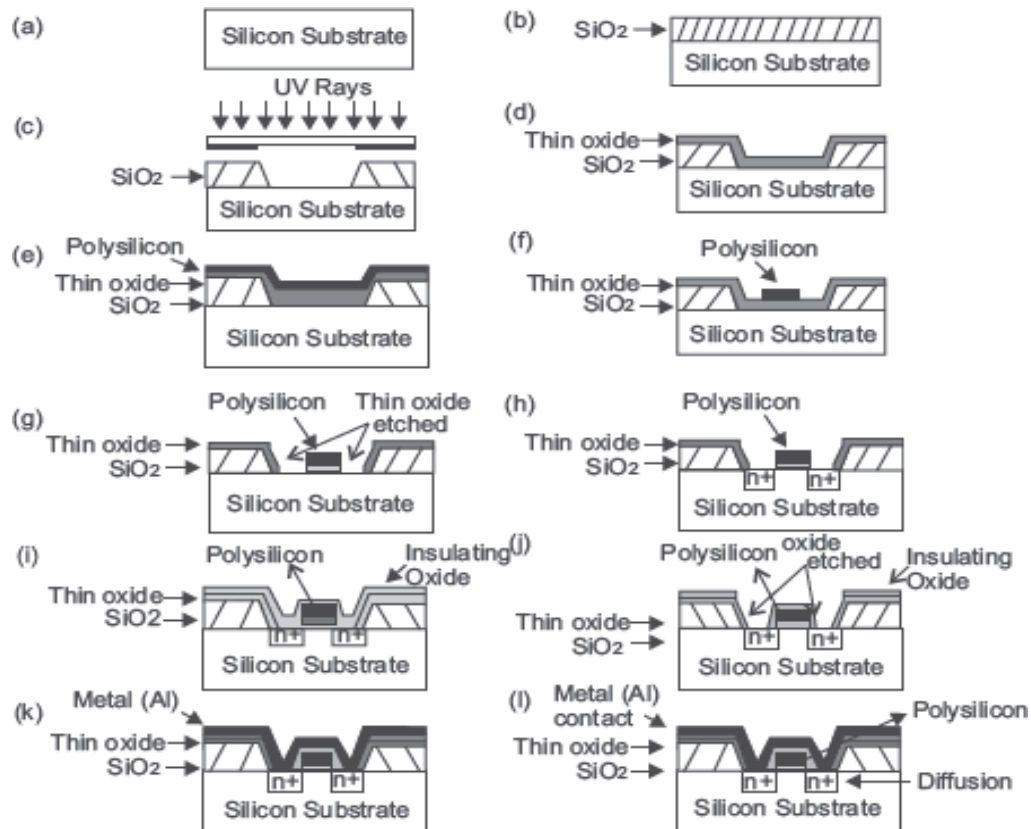

Figure 1.9: Fabrication Process of NMOS Device

### CMOS FABRICATION:

CMOS fabrication can be accomplished using either of the three technologies:

- N-well technologies/P-well technologies
- Twin well technology
- Silicon On Insulator (SOI)

The fabrication of CMOS can be done by following the below shown twenty steps, by which CMOS can be obtained by integrating both the NMOS and PMOS transistors on the same chip substrate. For integrating these NMOS and PMOS devices on the same chip, special regions called as wells or tubs are required in which semiconductor type and substrate type are opposite to each other.

A P-well has to be created on a N-substrate or N-well has to be created on a P-substrate. In this article, the fabrication of CMOS is described using the P-substrate, in which the NMOS transistor is fabricated on a P-type substrate and the PMOS transistor is fabricated in N-well.

The fabrication process involves twenty steps, which are as follows:

## N-Well Process

### Step1: Substrate

Primarily, start the process with a P-substrate.



### Step2: Oxidation

The oxidation process is done by using high-purity oxygen and hydrogen, which are exposed in an oxidation furnace approximately at 1000 degree centigrade.



### Step3: Photoresist

A light-sensitive polymer that softens whenever exposed to light is called as Photoresist layer.

It is formed.

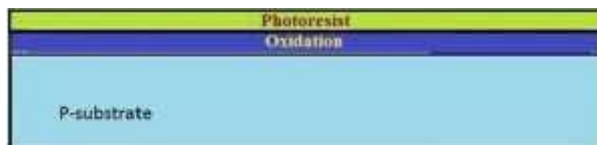

### Step4: Masking

The photoresist is exposed to UV rays through the N-well mask

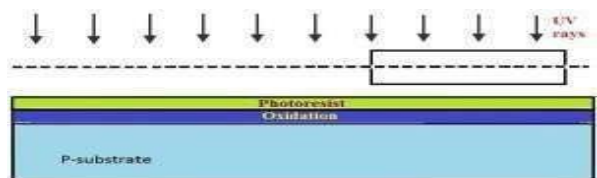

### Step5: Photoresist removal

A part of the photoresist layer is removed by treating the wafer with the basic or acidic solution.



### Step6: Removal of SiO<sub>2</sub> using acid etching

The SiO<sub>2</sub> oxidation layer is removed through the open area made by the removal of photoresist using hydrofluoric acid.

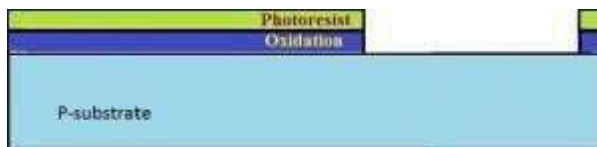

### Step7: Removal of photoresist

The entire photoresist layer is stripped off, as shown in the below figure.



### Step8: Formation of the N-well

By using ion implantation or diffusion process N-well is formed.

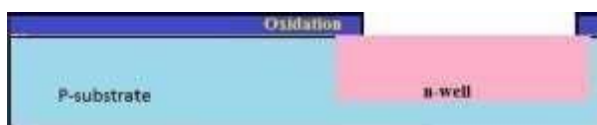

### Step9: Removal of SiO<sub>2</sub>

Using the hydrofluoric acid, the remaining SiO<sub>2</sub> is removed.



### Step10: Deposition of polysilicon

Chemical Vapor Deposition (CVD) process is used to deposit a very thin layer of gate oxide.

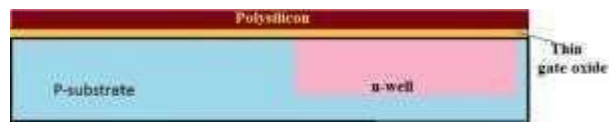

### Step11: Removing the layer barring a small area for the Gates

Except the two small regions required for forming the Gates of NMOS and PMOS, the remaining layer is stripped off.

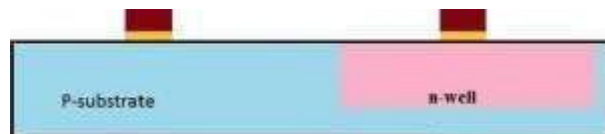

### Step12: Oxidation process

Next, an oxidation layer is formed on this layer with two small regions for the formation of the gate terminals of NMOS and PMOS.

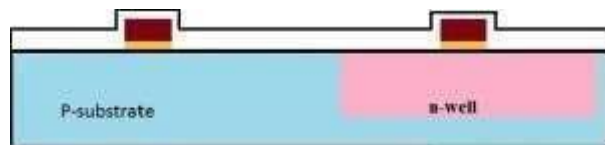

### Step13: Masking and N-diffusion

By using the masking process small gaps are made for the purpose of N -diffusion.



The n-type (n+) dopants are diffused or ion implanted, and the three n+ are formed for the formation of the terminals of NMOS.

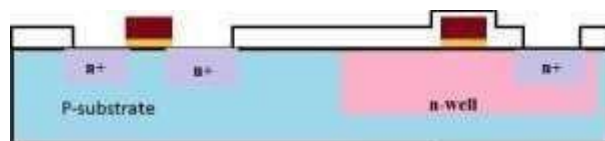

### Step14: Oxide stripping

The remaining oxidation layer is stripped off.

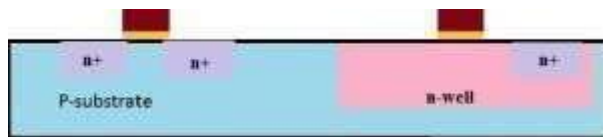

### Step15: P-diffusion

Similar to the above N-diffusion process, the P-diffusion regions are diffused to form the terminals of the PMOS.

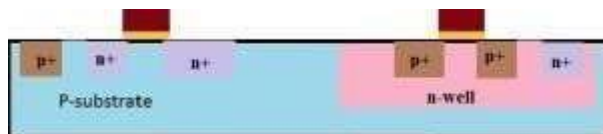

### Step16: Thick field oxide

A thick-field oxide is formed in all regions except the terminals of the PMOS and NMOS.

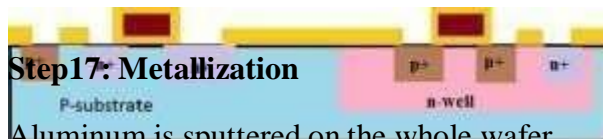

### Step17: Metallization

Aluminum is sputtered on the whole wafer.

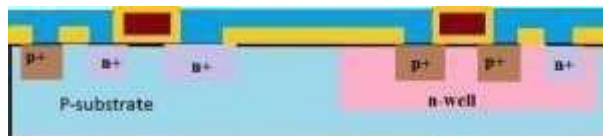

### Step18: Removal of excess metal

The excess metal is removed from the wafer layer.



### Step19: Terminals

The terminals of the PMOS and NMOS are made from respective gaps.



### Step20: Assigning the names of the terminals of the NMOS and PMOS

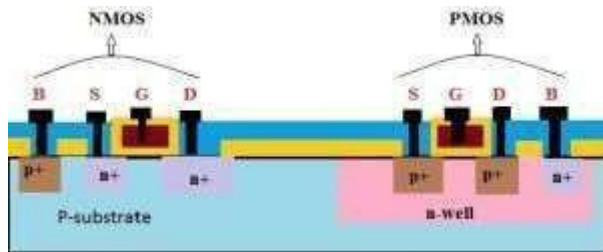

### Fabrication of CMOS using P-well process

Among all the fabrication processes of the CMOS, N-well process is mostly used for the fabrication of the CMOS. P-well process is almost similar to the N-well. But the only difference in p-well process is that it consists of a main N-substrate and, thus, P-wells itself acts as substrate for the N-devices.

### Twin tub-CMOS Fabrication Process

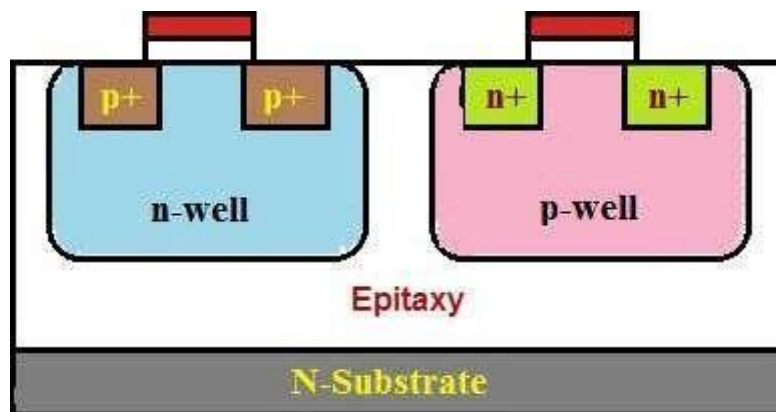

In this process, separate optimization of the **n-type and p-type transistors** will be provided. The independent optimization of  $V_t$ , body effect and gain of the P-devices, N-devices can be made possible with this process.

Different steps of the fabrication of the CMOS using the twintub process are as follows:

- Lightly doped n+ or p+ substrate is taken and, to protect the latch up, epitaxial layer is used.
- The high-purity controlled thickness of the layers of silicon are grown with exact dopant concentrations.
- The dopant and its concentration in Silicon are used to determine electrical properties.
- Formation of the tub
- Thin oxide construction

- Implantation of the source and drain
- Cuts for making contacts
- Metallization

By using the above steps we can fabricate CMOS using twin tub process method.

### **Silicon-on-Insulator (SOI) CMOS Process**

Rather than using silicon as the substrate material, technologists have sought to use an insulating substrate to improve process characteristics such as speed and latch-up susceptibility. The SOI CMOS technology allows the creation of independent, completely isolated nMOS and pMOS transistors virtually side-by-side on an insulating substrate. The main advantages of this technology are the higher integration density (because of the absence of well regions), complete avoidance of the latch-up problem, and lower parasitic capacitances compared to the conventional p & n-well or twin-tub CMOS processes. A cross-section of nMOS and pMOS devices using SOI process is shown below.

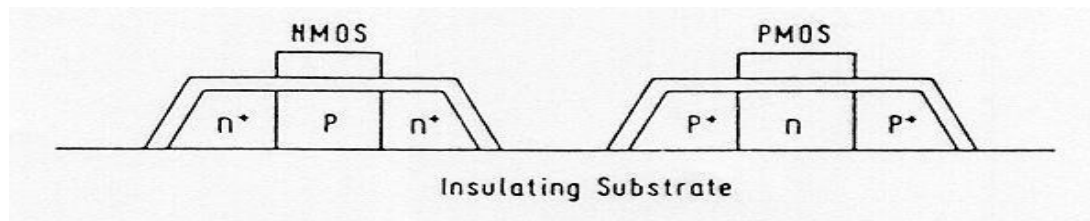

The SOI CMOS process is considerably more costly than the standard p & n-well CMOS process. Yet the improvements of device performance and the absence of latch-up problems can justify its use, especially for deep-sub-micron devices.

## Basic Electrical Properties of MOS and Bi CMOS circuits

### $I_D$ - $V_{DS}$ Characteristics of MOS Transistor :

The graph below shows the  $I_D$  Vs  $V_{DS}$  characteristics of an n- MOS transistor for several values of  $V_{GS}$ . It is clear that there are two conduction states when the device is ON. The saturated state and the non-saturated state. The saturated curve is the flat portion and defines the saturation region. For  $V_{GS} < V_{DS} + V_{th}$ , the nMOS device is conducting and  $I_D$  is independent of  $V_{DS}$ . For  $V_{GS} > V_{DS} + V_{th}$ , the transistor is in the non-saturation region and the curve is a half parabola. When the transistor is OFF ( $V_{GS} < V_{th}$ ), then  $I_D$  is zero for any  $V_{DS}$  value.

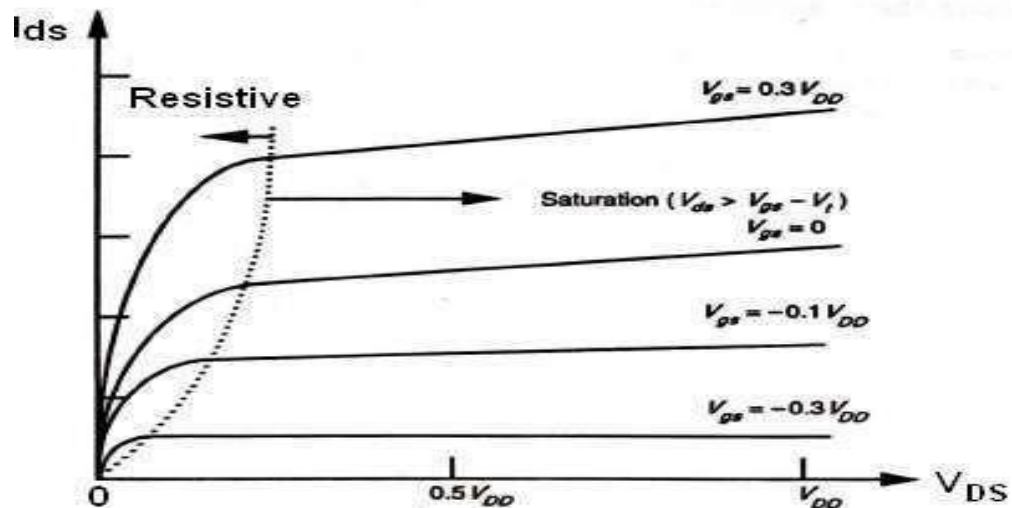

(a) Depletion mode device

The boundary of the saturation/non-saturation bias states is a point seen for each curve in the graph as the intersection of the straight line of the saturated region with the quadratic curve of the non-saturated region. This intersection point occurs at the channel pinch off voltage called  $V_{DSAT}$ . The diamond symbol marks the pinch-off voltage  $V_{DSAT}$  for each value of  $V_{GS}$ .  $V_{DSAT}$  is defined as the minimum drain-source voltage that is required to keep the transistor in saturation for a given  $V_{GS}$ . In the non-saturated state, the drain current initially increases almost linearly from the origin before bending in a parabolic response. Thus the name ohmic or linear for the non-saturated region.

The drain current in saturation is virtually independent of  $V_{DS}$  and the transistor acts as a current

source. This is because there is no carrier inversion at the drain region of the channel. Carriers are pulled into the high electric field of the drain/substrate pn junction and ejected out of the drain terminal.

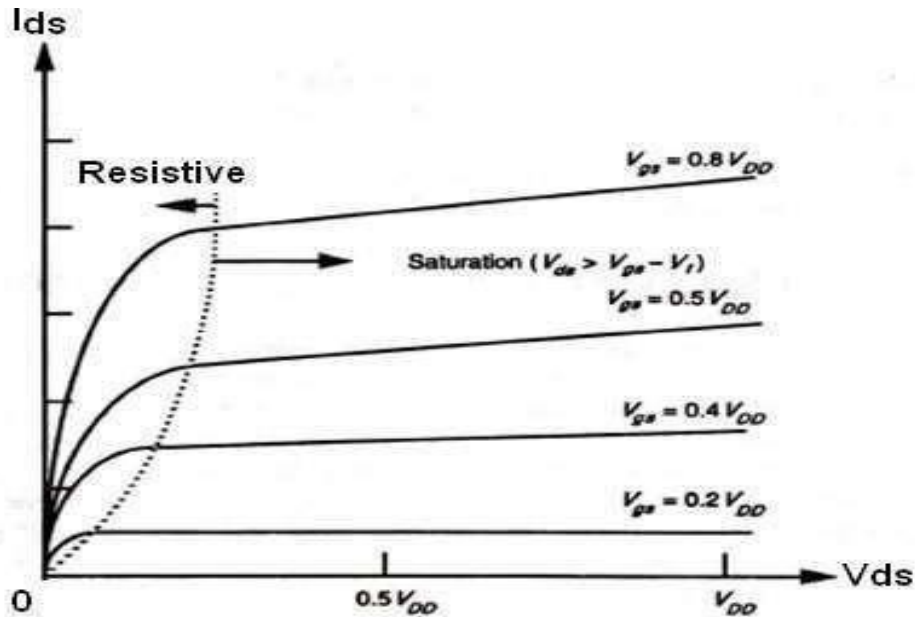

(b). Enhance mode device

### Drain-to-Source Current $I_{DS}$ Versus Voltage $V_{DS}$ Relationships :

The working of a MOS transistor is based on the principle that the use of a voltage on the gate induce a charge in the channel between source and drain, which may then be caused to move from source to drain under the influence of an electric field created by voltage  $V_{ds}$  applied between drain and source. Since the charge induced is dependent on the gate to source voltage  $V_{gs}$  then  $I_{ds}$  is dependent on both  $V_{gs}$  and  $V_{ds}$ .

Let us consider the diagram below in which electrons will flow source to drain .So,the drain current is given by

Charge induced in channel ( $Q_c$ )  $I_{ds} = -I_{sd} = \text{Electron transit time}(\tau) \text{ Length of the channel}$  Where the transit time is given by  $\tau_{sd} = \text{-----}$

Velocity ( $v$ )

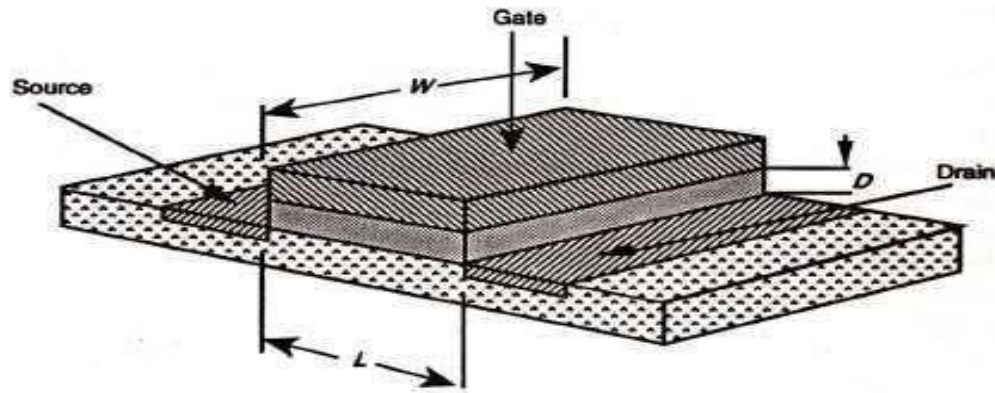

But velocity  $v = \mu E_{ds}$

Where  $\mu$  = electron or hole mobility and  $E_{ds}$  = Electric field also,  $E_{ds} = V_{ds}/L$

so,  $v = \mu \cdot V_{ds}/L$  and  $\tau_{ds} = L^2 / \mu \cdot V_{ds}$

The typical values of  $\mu$  at room temperature are given below.

$$\mu_n \approx 650 \text{ cm}^2/\text{V sec (surface)}$$

$$\mu_p \approx 240 \text{ cm}^2/\text{V sec (surface)}$$

### Non-saturated Region :

Let us consider the  $I_d$  vs  $V_d$  relationships in the non-saturated region. The charge induced in the channel due to the voltage difference between the gate and the channel,  $V_{gs}$  (assuming substrate connected to source). The voltage along the channel varies linearly with distance  $X$  from the source due to the IR drop in the channel. In the non-saturated state the average value is  $V_{ds}/2$ . Also the effective gate voltage  $V_g = V_{gs} - V_t$  where  $V_t$ , is the threshold voltage needed to invert the charge under the gate and establish the channel.

Hence the induced charge is  $Q_c = E_g \epsilon_{ins} \epsilon_0 W \cdot L$

Where

$E_g$  = average electric field gate to channel

$\epsilon_{ins}$  = relative permittivity of insulation between gate and channel  $\epsilon_0$  = permittivity

$$E_g = \frac{\left( (V_{gs} - V_t) - \frac{V_{ds}}{2} \right)}{D}$$

Here  $D$  is the thickness of the oxide layer. Thus

$$Q_c = \frac{WL\epsilon_{ins}\epsilon_0}{D} \left( (V_{gs} - V_t) - \frac{V_{ds}}{2} \right)$$

So, by combining the above two equations, we get

$$I_{ds} = \frac{\epsilon_{ins}\epsilon_0\mu}{D} \frac{W}{L} \left( (V_{gs} - V_t) - \frac{V_{ds}}{2} \right) V_{ds}$$

or the above equation can be written as

$$I_{ds} = K \frac{W}{L} \left( (V_{gs} - V_t) V_{ds} - \frac{V_{ds}^2}{2} \right)$$

In the non-saturated or resistive region where  $V_{ds} < V_{gs} - V_t$  and

$$K = \frac{\epsilon_{ins}\epsilon_0\mu}{D}$$

Generally, a constant  $\beta$  is defined as

$$\beta = K \frac{W}{L}$$

So that, the expression for drain-source current will become

$$I_{ds} = \beta \left( (V_{gs} - V_t) V_{ds} - \frac{V_{ds}^2}{2} \right)$$

The gate/channel capacitance is

$$C_g = \frac{\epsilon_{ins}\epsilon_0WL}{D} \text{ (parallel plate)}$$

Hence we can write another alternative form for the drain current as

$$I_{ds} = \frac{C_g \mu}{L^2} \left( (V_{gs} - V_t) V_{ds} - \frac{V_{ds}^2}{2} \right)$$

Some time it is also convenient to use gate –capacitance per unit area , $C_g$  So,the drain current is

$$I_{ds} = C_g \mu \frac{W}{L} \left( (V_{gs} - V_t) V_{ds} - \frac{V_{ds}^2}{2} \right)$$

This is the relation between drain current and drain-source voltage in non-saturated region.

### Saturated Region

Saturation begins when  $V_{ds} = V_{gs} - V_t$ , since at this point the IR drop in the channel equals the effective gate to channel voltage at the drain and we may assume that the current remains fairly constant as  $V_{ds}$  increases further. Thus

$$I_{ds} = K \frac{W}{L} \frac{(V_{gs} - V_t)^2}{2}$$

or we can also write that

$$I_{ds} = \frac{\beta}{2} (V_{gs} - V_t)^2$$

or it can also be written as

$$I_{ds} = \frac{C_g \mu}{2L^2} (V_{gs} - V_t)^2$$

or

$$I_{ds} = C_g \mu \frac{W}{2L} (V_{gs} - V_t)^2$$

The expressions derived above for  $I_{ds}$  hold for both enhancement and depletion mode devices. Here the threshold voltage for the nMOS depletion mode device (denoted as  $V_{td}$ ) is negative.

**MOS Transistor Threshold Voltage  $V_t$  :**

The gate structure of a MOS transistor consists, of charges stored in the dielectric layers and in the surface to surface interfaces as well as in the substrate itself. Switching an enhancement mode MOS transistor from the off to the on state consists in applying sufficient gate voltage to neutralize these charges and enable the underlying silicon to undergo an inversion due to the electric field from the gate. Switching a depletion mode nMOS transistor from the on to the off state consists in applying enough voltage to the gate to add to the stored charge and invert the 'n' implant region to 'p'.

The threshold voltage  $V_t$  may be expressed as:

$$V_t = \phi_{ms} + \frac{Q_B - Q_{SS}}{C_0} + 2\phi_{fN}$$

where  $Q_D$  = the charge per unit area in the depletion layer below the oxide  $Q_{SS}$  = charge density at Si: SiO<sub>2</sub> interface

$C_0$  = Capacitance per unit area.

$\phi_{ms}$  = work function difference between gate and Si

$\phi_{fN}$  = Fermi level potential between inverted surface and bulk Si

For polynomial gate and silicon substrate, the value of  $\phi_{ms}$  is negative but negligible and the magnitude and sign of  $V_t$  are thus determined by balancing the other terms in the equation. To evaluate the  $V_t$  the other terms are determined as below.

$$Q_B = \sqrt{2\epsilon_0\epsilon_{Si}qN(2\phi_{fN} + V_{SB})} \text{ coulomb/m}^2$$

$$\phi_{fN} = \frac{kT}{q} \ln \frac{N}{n_i} \text{ volts}$$

$$Q_{SS} = (1.5 \text{ to } 8) \times 10^{-8} \text{ coulomb/m}^2$$

**Body Effect :**

Generally while studying the MOS transistors it is treated as a three terminal device. But, the body of the transistor is also an implicit terminal which helps to understand the characteristics of the transistor. Considering the body of the MOS transistor as a terminal is known as the body effect. The potential difference between the source and the body ( $V_{sb}$ ) affects the threshold

voltage of the transistor. In many situations, this Body Effect is relatively insignificant, so we can (unless **otherwise** stated) ignore the Body Effect. But it is not always insignificant, in some cases it can have a tremendous impact on MOSFET circuit performance.

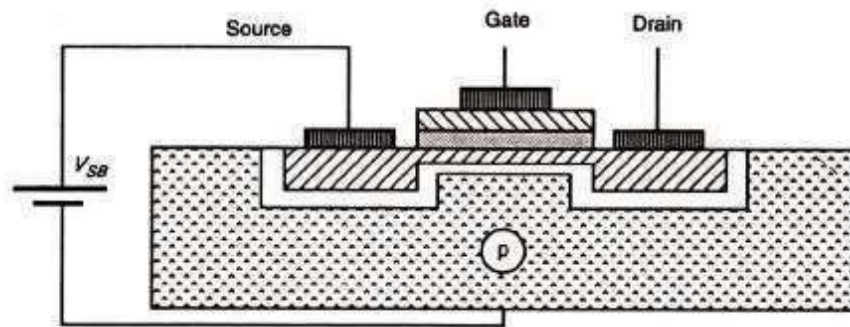

### Body effect - nMOS device

Increasing  $V_{sb}$  causes the channel to be depleted of charge carriers and thus the threshold voltage is raised. Change in  $V_t$  is given by  $\Delta V_t = \gamma \cdot (V_{sb})^{1/2}$  where  $\gamma$  is a constant which depends on substrate doping so that the more lightly doped the substrate, the smaller will be the body effect

The threshold voltage can be written as

$$V_t = V_t(0) + \left( \frac{D}{\epsilon_{ins} \epsilon_0} \right) \sqrt{2 \epsilon_0 \epsilon_{st} Q_N \cdot (V_{sb})^{1/2}}$$

Where  $V_t(0)$  is the threshold voltage for  $V_{sd} = 0$

For n-MOS depletion mode transistors, the body voltage values at different  $V_{DD}$  voltages are given below.

$V_{sb} = 0 \text{ V}$  ;  $V_{sd} = -0.7V_{DD}$  (= - 3.5 V for  $V_{DD} = +5\text{V}$  )  $V_{sb} = 5 \text{ V}$  ;  $V_{sd} = -0.6V_{DD}$  (= - 3.0 V for  $V_{DD} = +5\text{V}$  )

### nMOS INVERTER :

An inverter circuit is a very important circuit for producing a complete range of logic circuits. This is needed for restoring logic levels, for Nand and Nor gates, and for sequential and memory circuits of various forms .

A simple inverter circuit can be constructed using a transistor with source connected to ground and a load resistor of connected from the drain to the positive supply rail  $V_{DD}$ . The output is taken from the drain and the input applied between gate and ground .

But, during the fabrication resistors are not conveniently produced on the silicon substrate and even small values of resistors occupy excessively large areas .Hence some other form of load resistance is used. A more convenient way to solve this problem is to use a depletion mode transistor as the load, as shown in Fig. below.

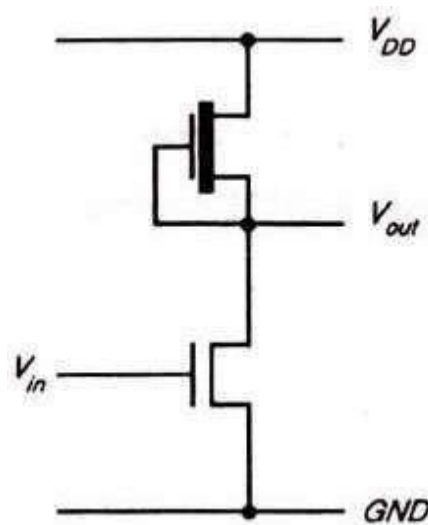

The salient features of the n-MOS inverter are

- For the depletion mode transistor, the gate is connected to the source so it is always on .
- In this configuration the depletion mode device is called the pull-up (P.U) and the enhancement mode device the pull-down (P.D) transistor.
- With no current drawn from the output, the currents  $I_{ds}$  for both transistors must be equal.

#### **nMOS Inverter transfer characteristic.**

The transfer characteristic is drawn by taking  $V_{ds}$  on x-axis and  $I_{ds}$  on Y-axis for both enhancement and depletion mode transistors. So, to obtain the inverter transfer characteristic for

$V_{gs} = 0$  depletion mode characteristic curve is superimposed on the family of curves for the enhancement mode device and from the graph it can be seen that , maximum voltage across the enhancement mode device corresponds to minimum voltage across the depletion mode transistor.

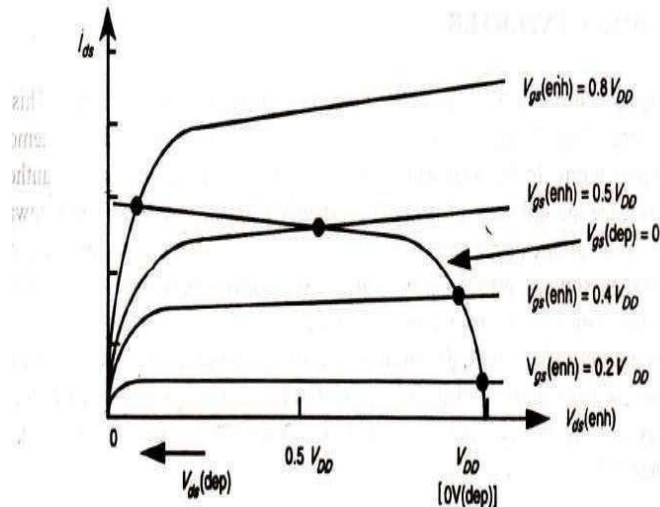

From the graph it is clear that as  $V_{in}(=V_{gs} \text{ p.d. transistor})$  exceeds the Pulldown threshold voltage current begins to flow. The output voltage  $V_{out}$  thus decreases and the subsequent increases in  $V_{in}$  will cause the Pull down transistor to come out of saturation and become resistive.

### CMOS Inverter:

The inverter is the very important part of all digital designs. Once its operation and properties are clearly understood, Complex structures like NAND gates, adders, multipliers, and microprocessors can also be easily done. The electrical behavior of these complex circuits can be almost completely derived by extrapolating the results obtained for inverters. As shown in the diagram below the CMOS transistor is designed using p-MOS and n-MOS transistors.

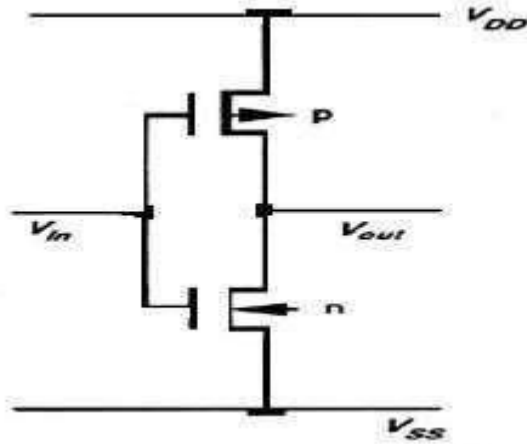

In the inverter circuit, if the input is high, the lower n-MOS device closes to discharge the capacitive load. Similarly, if the input is low, the top p-MOS device is turned on to charge the capacitive load. At no time both the devices are on, which prevents the DC current flowing from positive power supply to ground. Qualitatively this circuit acts like the switching circuit, since the p-channel transistor has exactly the opposite characteristics of the n-channel transistor. In the transition region both transistors are saturated and the circuit operates with a large voltage gain. The C-MOS transfer characteristic is shown in the below graph.

Considering the static conditions first, it may be seen that in region 1 for which  $V_{in} = \text{logic } 0$ , we have the p-transistor fully turned on while the n-transistor is fully turned off. Thus no current flows through the inverter and the output is directly connected to  $V_{DD}$  through the p-transistor.

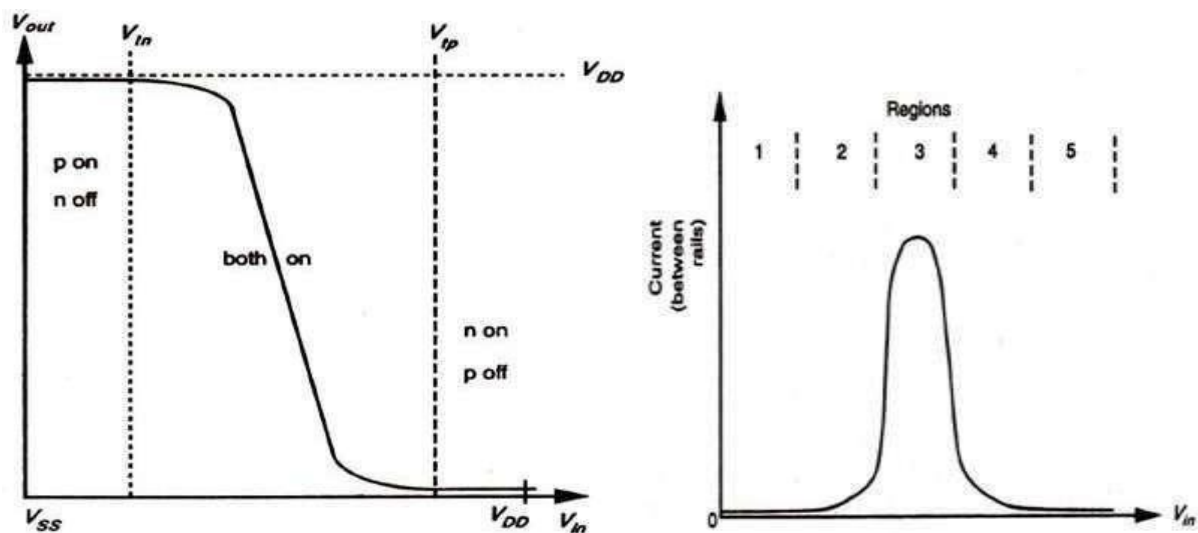

Hence the output voltage is logic 1. In region 5,  $V_{in} = \text{logic } 1$  and the n-transistor is fully on while the p-transistor is fully off. So, no current flows and logic 0 appears at the output.

In region 2 the input voltage has increased to a level which just exceeds the threshold voltage of the n-transistor. The n-transistor conducts and has a large voltage between source and drain; so it is in saturation. The p-transistor is also conducting but with only a small voltage across it, it operates in the unsaturated resistive region. A small current now flows through the inverter from VDD to VSS. If we wish to analyze the behavior in this region, we equate the p-device resistive region current with the n-device saturation current and thus obtain the voltage and current relationships.

Region 4 is similar to region 2 but with the roles of the p- and n-transistors reversed. However, the current magnitudes in regions 2 and 4 are small and most of the energy consumed in switching from one state to the other is due to the larger current which flows in region 3.

Region 3 is the region in which the inverter exhibits gain and in which both transistors are in saturation.

The currents in each device must be the same, since the transistors are in series. So, we can write that

$$I_{dsp} = -I_{dsn}$$

where

$$I_{dsp} = \frac{\beta_p}{2} (V_{in} - V_{DD} - V_{tp})^2$$

and

$$I_{dsn} = \frac{\beta_n}{2} (V_{in} - V_{tn})^2$$

Since both transistors are in saturation, they act as current sources so that the equivalent circuit in this region is two current sources in series between VDD and VSS with the output voltage coming from their common point. The region is inherently unstable in consequence and the changeover from one logic level to the other is rapid.

#### **Determination of Pull-up to Pull-Down Ratio ( $Z_{p.u}/Z_{p.d}$ ) for an nMOS Inverter driven by another nMOS Inverter :**

Let us consider the arrangement shown in Fig.(a). in which an inverter is driven from the output of another similar inverter. Consider the depletion mode transistor for which  $V_{gs} = 0$  under all conditions, and also assume that in order to cascade inverters without degradation the condition

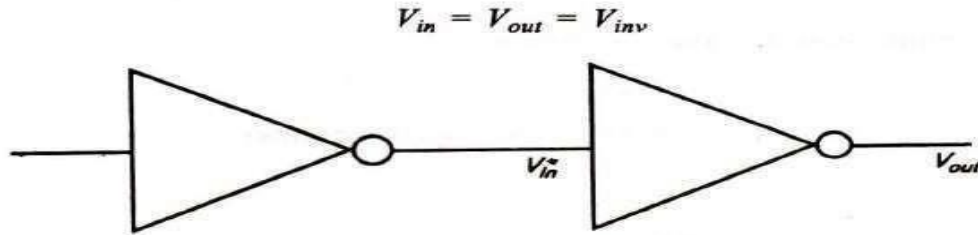

Fig.(a).Inverter driven by another inverter.

For equal margins around the inverter threshold, we set  $V_{inv} = 0.5V_{DD}$ . At this point both transistors are in saturation and we can write that

$$I_{ds} = K \frac{W}{L} \frac{(V_{gs} - V_t)^2}{2}$$

In the depletion mode  $I_{ds} = K \frac{W_{p.u.}}{L_{p.u.}} \frac{(-V_{td})^2}{2}$  since  $V_{gs} = 0$

and in the enhancement mode

$$I_{ds} = K \frac{W_{p.d.}}{L_{p.d.}} \frac{(V_{inv} - V_t)^2}{2} \text{ since } V_{gs} = V_{inv}$$

Equating (since currents are the same) we have

$$\frac{W_{p.d.}}{L_{p.d.}} (V_{inv} - V_t)^2 = \frac{W_{p.u.}}{L_{p.u.}} (-V_{td})^2$$

where  $W_{p.d}$ ,  $L_{p.d}$ ,  $W_{p.u.}$  and  $L_{p.u.}$  are the widths and lengths of the pull-down and pull-up transistors respectively.

So, we can write that

$$Z_{p.d.} = \frac{L_{p.d.}}{W_{p.d.}}; Z_{p.u.} = \frac{L_{p.u.}}{W_{p.u.}}$$

we have

$$\frac{1}{Z_{p.d.}} (V_{inv} - V_t)^2 = \frac{1}{Z_{p.u.}} (-V_{td})^2$$

whence

$$V_{inv} = V_t + \frac{V_{td}}{\sqrt{Z_{p.u.}/Z_{p.d.}}}$$

The typical, values for  $V_t$ ,  $V_{inv}$  and  $V_{td}$  are

$$V_t = 0.2V_{DD}; V_{td} = -0.6V_{DD}$$

$$V_{inv} = 0.5V_{DD} \text{ (for equal margins)}$$

Substituting these values in the above equation ,we get

$$0.5 = 0.2 + \frac{0.6}{\sqrt{Z_{p.u.}/Z_{p.d.}}}$$

Here

$$\sqrt{Z_{p.u.}/Z_{p.d.}} = 2$$

So,we get

$$\boxed{Z_{p.u.}/Z_{p.d.} = 4/1}$$

This is the ratio for pull-up to pull down ratio for an inverter directly driven by another inverter.

### **Pull -Up to Pull-Down ratio for an nMOS Inverter driven through one or more Pass Transistors**

Let us consider an arrangement in which the input to inverter 2 comes from the output of inverter 1

but passes through one or more nMOS transistors as shown in Fig. below (These transistors are called pass transistors).

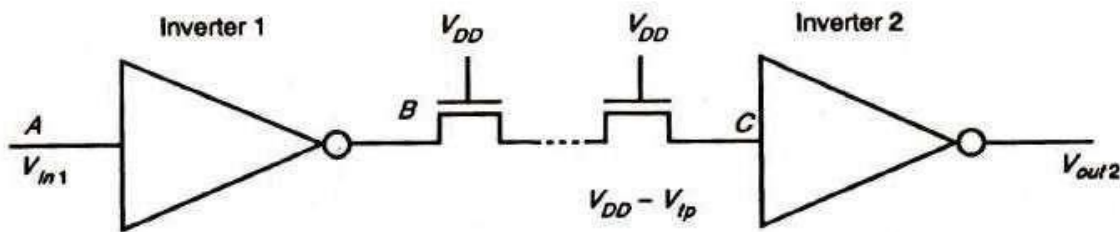

The connection of pass transistors in series will degrade the logic 1 level / into inverter 2 so that the output will not be a proper logic 0 level. The critical condition is , when point A is at 0 volts and B is thus at VDD. but the voltage into inverter 2 at point C is now reduced from VDD by the threshold voltage of the series pass transistor. With all pass transistor gates connected to VDD there is a loss of  $V_{tp}$ , however many are connected in series, since no static current flows through them and there can be no voltage drop in the channels. Therefore, the input voltage to inverter 2 is

$V_{in2} = V_{DD} - V_{tp}$  where  $V_{tp}$  = threshold voltage for a pass transistor.

Let us consider the inverter 1 shown in Fig.(a) with input = VDD. If the input is at VDD , then the pull-down transistor T2 is conducting but with a low voltage across it; therefore, it is in its resistive region represented by  $R_1$  in Fig.(a) below. Meanwhile, the pull up transistor T1 is in saturation and is represented as a current source.

For the pull down transistor

$$R_1 = \frac{V_{ds1}}{I_{ds}} = \frac{1}{K} \frac{L_{p.d.1}}{W_{p.d.1}} \left( \frac{1}{V_{DD} - V_t - \frac{V_{ds1}}{2}} \right)$$

$$I_{ds} = K \frac{W_{p.d.1}}{L_{p.d.1}} \left( (V_{DD} - V_t) V_{ds1} - \frac{V_{ds1}^2}{2} \right)$$

Since  $V_{ds}$  is small,  $V_{ds}/2$  can be neglected in the above expression.

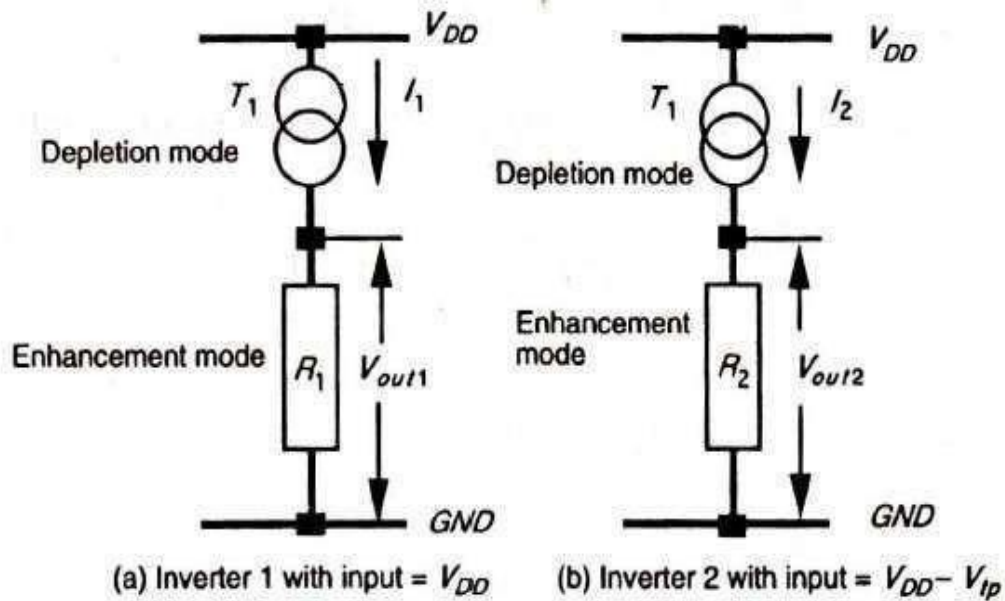

So,

$$R_1 \doteq \frac{1}{K} Z_{p.d.1} \left( \frac{1}{V_{DD} - V_t} \right)$$

Now, for depletion mode pull-up transistor in saturation with  $V_{gs} = 0$

$$I_1 = I_{ds} = K \frac{W_{p.u.1}}{L_{p.u.1}} \frac{(-V_{td})^2}{2}$$

The product  $1R_1 = V_{out1}$  So,

$$V_{out1} = I_1 R_1 = \frac{Z_{p.d.1}}{Z_{p.u.1}} \left( \frac{1}{V_{DD} - V_t} \right) \frac{(V_{td})^2}{2}$$

Let us now consider the inverter 2 Fig.b .when input =  $V_{DD} - V_{tp}$ .

$$R_2 \doteq \frac{1}{K} Z_{p.d.2} \frac{1}{((V_{DD} - V_{tp}) - V_t)}$$

$$I_2 = K \frac{1}{Z_{p.u.2}} \frac{(-V_{td})^2}{2}$$

Whence,

$$V_{out2} = I_2 R_2 = \frac{Z_{p.d.2}}{Z_{p.u.2}} \left( \frac{1}{V_{DD} - V_{tp} - V_t} \right) \frac{(-V_{td})^2}{2}$$

If inverter 2 is to have the same output voltage under these conditions then  $V_{out1} = V_{out2}$ . That is

$$I_1 R_1 = I_2 R_2$$

therefore

$$\frac{Z_{p.u.2}}{Z_{p.d.2}} = \frac{Z_{p.u.1}}{Z_{p.d.1}} \frac{(V_{DD} - V_t)}{(V_{DD} - V_{tp} - V_t)}$$

Considering the typical values

$$V_t = 0.2V_{DD}$$

$$V_{tp} = 0.3V_{DD}^*$$

$$\frac{Z_{p.u.2}}{Z_{p.d.2}} = \frac{Z_{p.u.1}}{Z_{p.d.1}} \frac{0.8}{0.2}$$

Therefore

$$\frac{Z_{p.u.2}}{Z_{p.d.2}} \doteq 2 \frac{Z_{p.u.1}}{Z_{p.d.1}} = \frac{8}{1}$$

From the above theory it is clear that, for an n-MOS transistor

- (i). An inverter driven directly from the output of another should have a  $Z_{p.u}/Z_{p.d}$  ratio of  $\geq 4/1$ .
- (ii). An inverter driven through one or more pass transistors should have a  $Z_{p.u}/Z_{p.d}$  ratio of  $\geq 8/1$

### ALTERNATIVE FORMS OF PULL -UP

Generally the inverter circuit will have a depletion mode pull-up transistor as its load. But there are also other configurations. Let us consider four such arrangements.

(i). **Load resistance  $R_L$**  : This arrangement consists of a load resistor as a pull-up as shown in the diagram below. But it is not widely used because of the large space requirements of resistors produced in a silicon substrate.

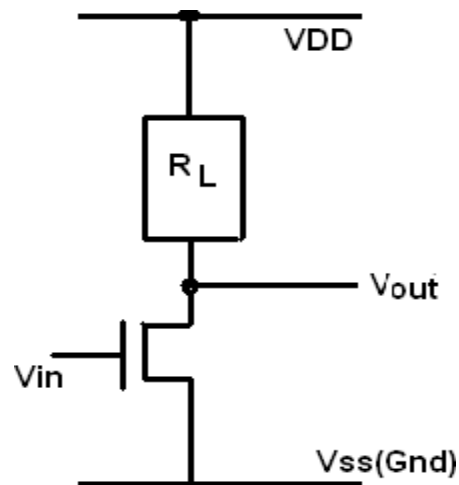

**nMOS depletion mode transistor pull-up** : This arrangement consists of a depletion mode transistor as pull-up. The arrangement and the transfer characteristic are shown below. In this type of arrangement we observe

- (a) Dissipation is high, since rail to rail current flows when  $V_{in} = \text{logical } 1$ .
- (b) Switching of output from 1 to 0 begins when  $V_{in}$  exceeds  $V_t$ , of pull-down device.

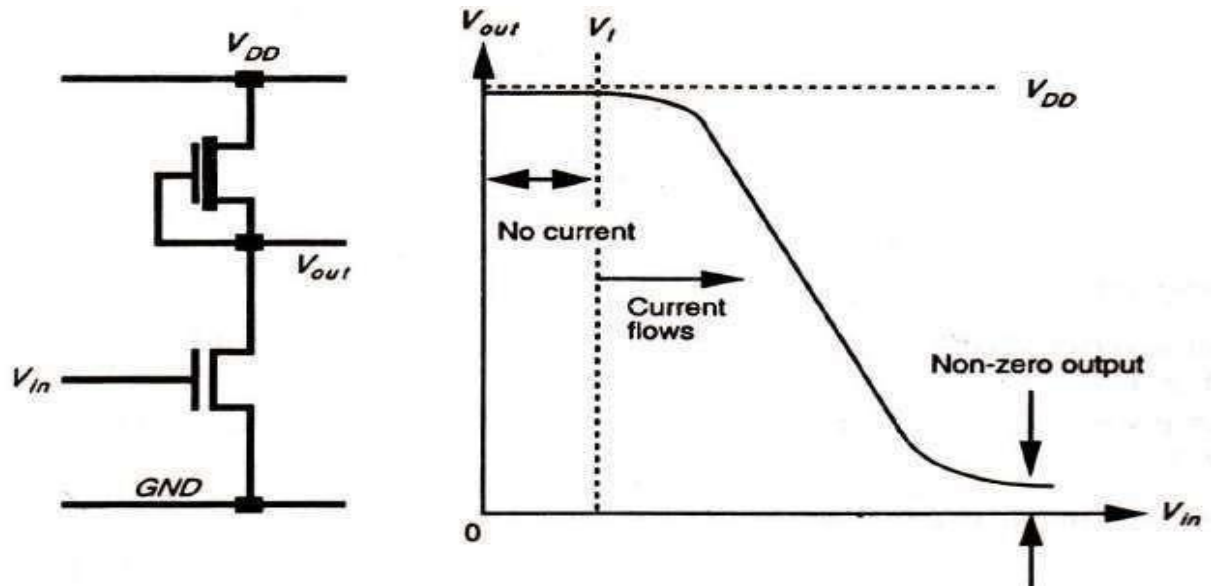

### nMOS depletion mode transistor pull-up and transfer characteristic

(c) When switching the output from 1 to 0, the pull-up device is non-saturated initially and this presents lower resistance through which to charge capacitive loads.

(ii) **nMOS enhancement mode pull-up** : This arrangement consists of a n-MOS enhancement mode transistor as pull-up. The arrangement and the transfer characteristic are shown below.

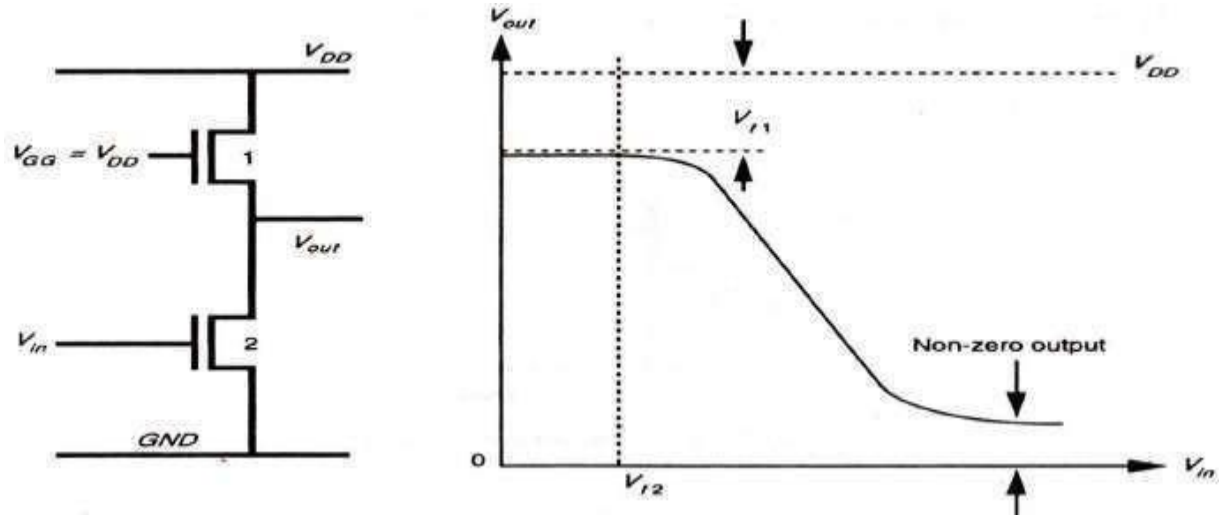

### nMOS enhancement mode pull-up and transfer characteristic

The important features of this arrangement are

- (a) Dissipation is high since current flows when  $V_{in} = \text{logical 1}$  ( $V_{GG}$  is returned to  $V_{DD}$ ).
- (b)  $V_{out}$  can never reach  $V_{DD}$  (logical 1) if  $V_{GG} = V_{DD}$  as is normally the case.
- (c)  $V_{GG}$  may be derived from a switching source, for example, one phase of a clock, so that

dissipation can be greatly reduced.

(d) If  $V_{GG}$  is higher than  $V_{DD}$  then an extra supply rail is required.

(iii) **Complementary transistor pull-up (CMOS)** : This arrangement consists of a C-MOS arrangement as pull-up. The arrangement and the transfer characteristic are shown below

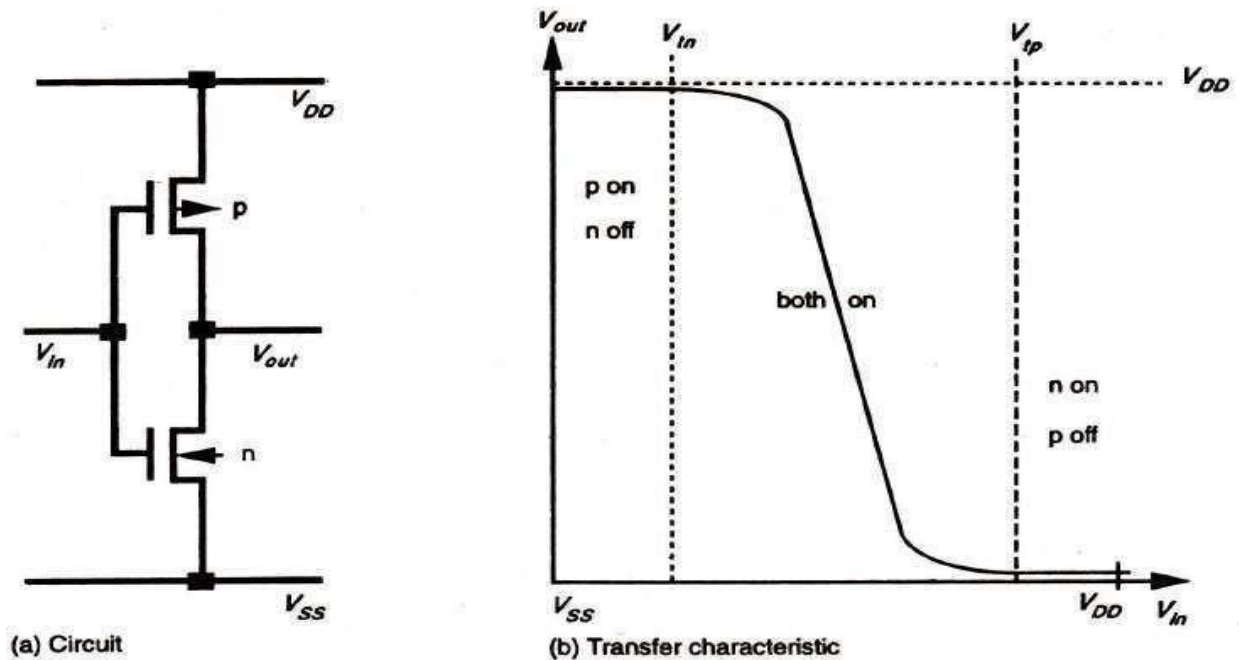

**The salient features of this arrangement are**

- No current flows either for logical 0 or for logical 1 inputs.
- Full logical 1 and 0 levels are presented at the output.
- For devices of similar dimensions the p-channel is slower than the n-channel device.

#### **BiCMOS INVERTER:**

A BiCMOS inverter, consists of a PMOS and NMOS transistor (  $M_2$  and  $M_1$ ), two NPN bipolar junction transistors, (  $Q_2$  and  $Q_1$ ), and two impedances which act as loads (  $Z_2$  and  $Z_1$ ) as shown in the circuit below.

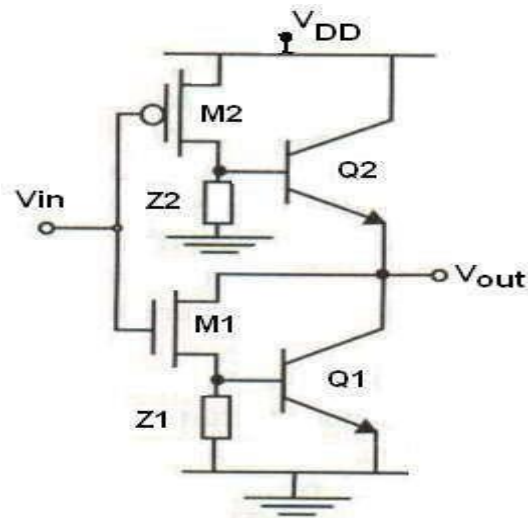

When input,  $V_{in}$ , is high ( $V_{DD}$ ), the NMOS transistor ( $M1$ ), turns on, causing  $Q1$  to conduct, while  $M2$  and  $Q2$  are off, as shown in figure (b). Hence, a low (GND) voltage is translated to the output  $V_{out}$ . On the other hand, when the input is low, the  $M2$  and  $Q2$  turns on, while  $M1$  and  $Q1$  turns off, resulting to a high output level at the output as shown in Fig.(b).

In steady-state operation,  $Q1$  and  $Q2$  never turns on or off simultaneously, resulting to a lower power consumption. This leads to a push-pull bipolar output stage. Transistors  $M1$  and  $M2$ , on the other hand, works as a phase-splitter, which results to a higher input impedance.

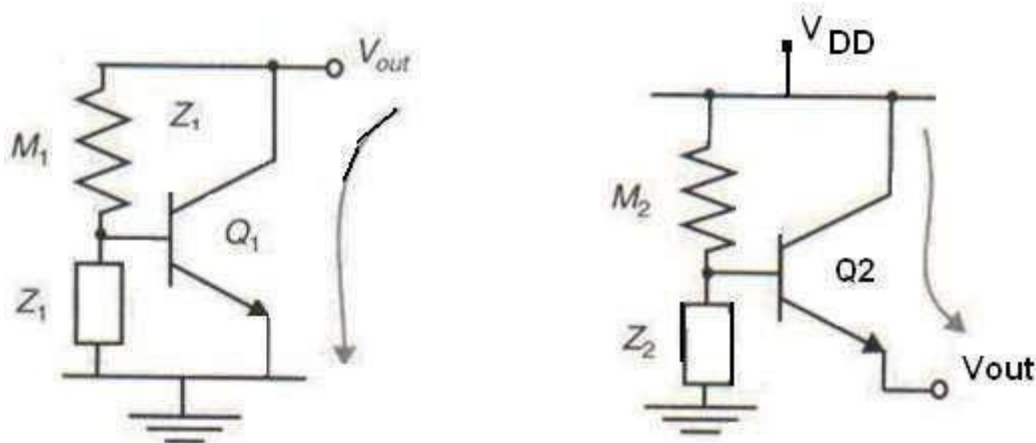

The impedances  $Z2$  and  $Z1$  are used to bias the base-emitter junction of the bipolar transistor and to ensure that base charge is removed when the transistors turn off. For example when the input voltage makes a high-to-low transition,  $M1$  turns off first. To turn off  $Q1$ , the base charge must be removed, which can be achieved by  $Z1$ . With this effect, transition time reduces. However,

there exists a short time when both Q1 and Q2 are on, making a direct path from the supply (VDD) to the ground. This results to a current spike that is large and has a detrimental effect on both the noise and power consumption, which makes the turning off of the bipolar transistor fast .

### **Comparison of BiCMOS and C-MOS technologies**

The BiCMOS gates perform in the same manner as the CMOS inverter in terms of power consumption, because both gates display almost no static power consumption.

When comparing BiCMOS and CMOS in driving small capacitive loads, their performance are comparable, however, making BiCMOS consume more power than CMOS. On the other hand, driving larger capacitive loads makes BiCMOS in the advantage of consuming less power than CMOS, because the construction of CMOS inverter chains are needed to drive large capacitance loads, which is not needed in BiCMOS.

The BiCMOS inverter exhibits a substantial speed advantage over CMOS inverters, especially when driving large capacitive loads. This is due to the bipolar transistor's capability of effectively multiplying its current.

For very low capacitive loads, the CMOS gate is faster than its BiCMOS counterpart due to small values of  $C_{int}$ . This makes BiCMOS ineffective when it comes to the implementation of internal gates for logic structures such as ALUs, where associated load capacitances are small.

BiCMOS devices have speed degradation in the low supply voltage region and also BiCMOS is having greater manufacturing complexity than CMOS.

**Assignment Questions:**

1. Define threshold voltage? Drive the  $V_t$  equation for MOS transistor.
2. Explain with neat diagrams the various NMOS fabrication technology.
3. Draw and explain BiCMOS inverter circuit.
4. Discuss the Basic Electrical Properties of MOS and BiCMOS Circuits.
5. Derive the expression for estimation of Pull-Up to Pull-Down ratio of an n-MOS inverter driven by another n-MOS inverter.
6. Derive the relationship between  $I_{ds}$  and  $V_{ds}$
7. Derive the expression for transfer characteristics of CMOS Inverter.
8. Write about BiCMOS fabrication in a n-well process with a diagram.
9. Distinguish between Bipolar and CMOS devices technologies in brief.
10. Mention about the BICMOS Inverters and alternative BICMOS Inverters.
11. Determine the pull-up to pull down ratio for NMOS inverter driven by another NMOS Inverter
12. Draw the fabrication steps of CMOS transistor and explain its operation in detail.
13. Draw the fabrication steps of NMOS transistor and explain its operation in detail.

# UNIT II

## VLSI Circuit Design Processes

- **VLSI Design Flow**
- **MOS Layers**
- **Stick Diagrams**
- **Design Rules and Layout**
- **Lambda ( $\lambda$ ) based design rules for wires, contacts and Transistors**
- **Layout Diagrams for NMOS and CMOS Inverters and Gates**
- **Scaling of MOS circuits**

### VLSI DESIGN FLOW

A design flow is a sequence of operations that transform the IC designers' intention (usually represented in RTL format) into layout GDSII data.

A well-tuned design flow can help designers go through the chip-creation process relatively smoothly and with a decent chance of error-free implementation. And, a skilful IC implementation engineer can use the design flow creatively to shorten the design cycle, resulting in a higher likelihood that the product will catch the market window.

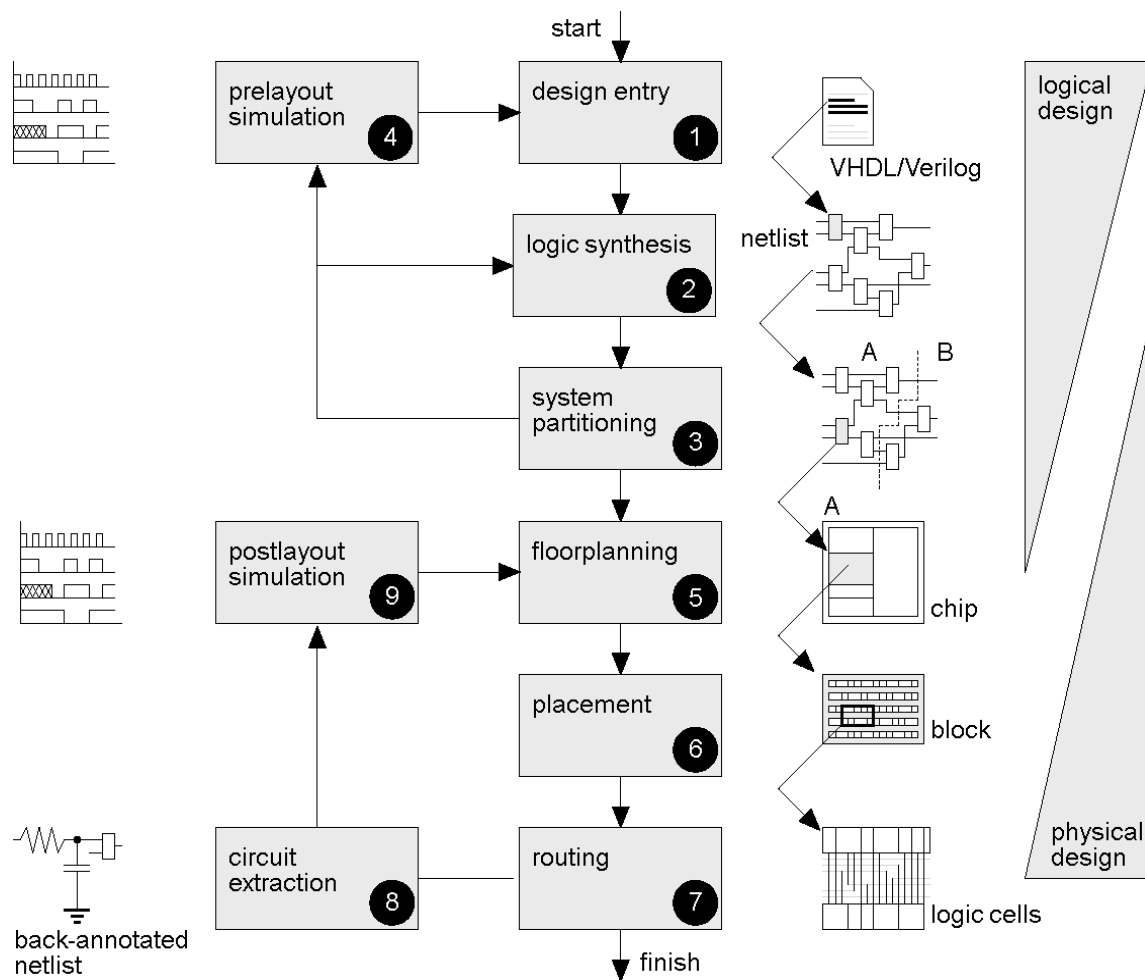

**Front-end design (Logical design):**

1. **Design entry** – Enter the design in to an ASIC design system using a hardware description language (HDL) or schematic entry
2. **Logic synthesis** – Generation of net list (logic cells and their connections) from HDL code. Logic synthesis consists of following steps: (i) Technology independent Logic optimization (ii) Translation: Converting Behavioral description to structural domain (iii) Technology mapping or Library binding
3. **System partitioning** - Divide a large system into ASIC-sized pieces
4. **Pre-layout simulation** - Check to see if the design functions correctly. Gate level functionality and timing details can be verified.

**Back-end design (Physical design):**

5. **Floor planning** - Arrange the blocks of the netlist on the chip
6. **Placement** - Decide the locations of cells in a block
7. **Routing** - Make the connections between cells and blocks
8. **Circuit Extraction** - Determine the resistance and capacitance of the interconnect
9. **Post-layout simulation** - Check to see the design still works with the added loads of the interconnect

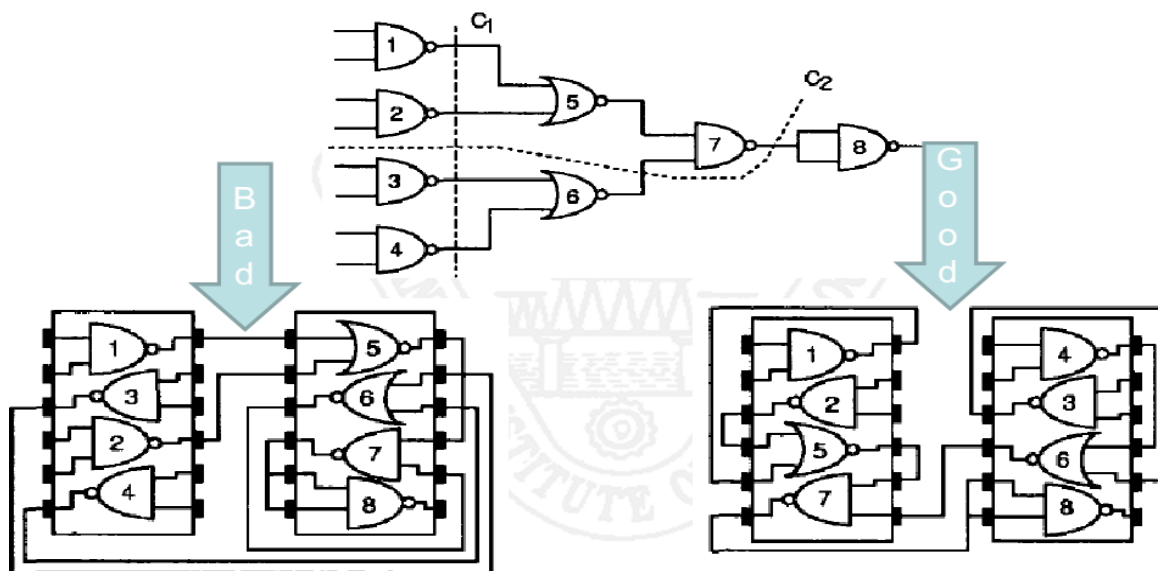
**Partitioning**

## MOS LAYERS

MOS design is aimed at turning a specification into masks for processing silicon to meet the specification. We have seen that MOS circuits are formed on four basic layers

- N-diffusion
- P-diffusion
- Poly Si
- Metal

which are isolated from one another by thick or thin (thinox) silicon silicon dioxide insulating layers. The thin oxide (thinox) mask region includes n-diffusion, p-diffusion, and transistor channels. Polysilicon and thinox regions interact so that a transistor is formed where they cross one another.

## STICK DIAGRAMS

A stick diagram is a diagrammatic representation of a chip layout that helps to abstract a model for design of full layout from traditional transistor schematic. Stick diagrams are used to convey the layer information with the help of a color code.

*“A stick diagram is a cartoon of a layout.”*

The designer draws a freehand sketch of a layout, using colored lines to represent the various process layers such as diffusion, metal and polysilicon. Where polysilicon crosses diffusion, transistors are created and where metal wires join diffusion or polysilicon, contacts are formed.

For example, in the case of nMOS design,

- Green color is used for n-diffusion
- Red for polysilicon
- Blue for metal
- Yellow for implant, and black for contact areas.







Monochrome encoding is also used in stick diagrams to represent the layer information.

**Stick Diagrams –NMOS Encoding**

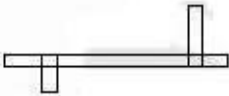
COLOR	STICK ENCODING	LAYERS	MASK LAYOUT ENCODING	CIF LAYER
GREEN		n-diffusion (n+ active) Thinox*		ND
RED		Polysilicon		NP
BLUE		Metal 1		NM
BLACK		Contact cut		NC
GRAY	NOT APPLICABLE	Overglass		NG
nMOS ONLY YELLOW		Implant		NI
nMOS ONLY BROWN		Buried contact		NB
FEATURE	FEATURE (STICK)	FEATURE (SYMBOL)	FEATURE (MASK)	
n-type enhancement mode transistor				
Transistor length to width ratio L: W should be shown.				
n-type depletion mode transistor nMOS only				
Source, drain and gate labelling will not normally be shown.				

**NMOS ENCODING**

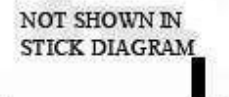
CMOS ENCODING

STICK ENCODING	LAYERS
<p>Monochrome</p> 	<p>n-diffusion (n+ active) Thinox</p>
	<p>Polysilicon</p>
	<p>Metal 1</p>
<p>●</p> <p>NOT APPLICABLE</p>	<p>Contact cut</p> <p>Overglass</p>
	<p>p-diffusion (p+ active)</p>
<p>NOT SHOWN IN STICK DIAGRAM</p> 	<p>p+ mask</p> <p>Metal 2</p>
<p>●</p> <p>DEMARCATION LINE</p> <p>p-well edge is shown as a demarcation line in stick diagrams</p> 	<p>VIA</p> <p>p-well</p> <p><math>V_{DD}</math> or <math>V_{SS}</math> CONTACT</p>

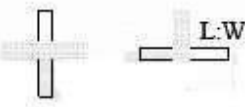
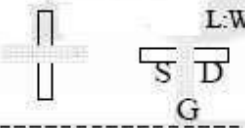
FEATURE	FEATURE (STICK) (MONOCHROME)
<p>n-type enhancement mode transistor (as in figure 1(a))</p>	 <p>Transistor length to width ratio L:W may be shown.</p>
<p>p-type enhancement mode transistor</p>	 <p>DEMARCATION LINE</p>

Stick Diagrams – Some Rules**Rule 1:**

When two or more ‘sticks’ of the same type cross or touch each other that represents electrical contact.

**Rule 2:**

When two or more “sticks” of different type cross or touch each other there is no electrical contact. (If electrical contact is needed we have to show the connection explicitly)



**Rule 3:**

When a poly crosses diffusion it represents a transistor.



Note: If a contact is shown then it is not a transistor.

**Rule 4:**

In CMOS a demarcation line is drawn to avoid touching of p-diff with n-diff. All PMOS must lie on one side of the line and all NMOS will have to be on the other side.



**nMOS Design Style :**

To understand the design rules for nMOS design style , let us consider a single metal, single polysilicon nMOS technology.

The layout of nMOS is based on the following important features.

- ✓ n-diffusion [n-diff.] and other thin oxide regions [thinox] (green) ;
- ✓ polysilicon 1 [poly.]-since there is only one polysilicon layer here (red);
- ✓ metal 1 [metal]-since we use only one metal layer here (blue);
- ✓ implant (yellow);
- ✓ contacts (black or brown [buried]).

A transistor is formed wherever poly. crosses n-diff. (red over green) and all diffusion wires (interconnections) are n-type (green).When starting a layout, the first step normally taken is to draw the metal (blue)  $V_{DD}$  and GND rails in parallel allowing enough space between them for the other circuit elements which will be required. Next, thinox (green) paths may be drawn between the rails for inverters and inverter based logic as shown in Fig. below. Inverters and inverter-based logic comprise a pull-up structure, usually a depletion mode transistor, connected from the output point to  $V_{DD}$  and a pull down structure of enhancement mode transistors suitably interconnected between the output point and GND. This is illustrated in the Fig.(b). remembering that poly. (red) crosses thinox (green)wherever transistors are required. One should consider the implants (yellow) for depletion mode transistors and also consider the length to width (L:W) ratio for each transistor. These ratios are important particularly in nMOS and nMOS- like circuits.

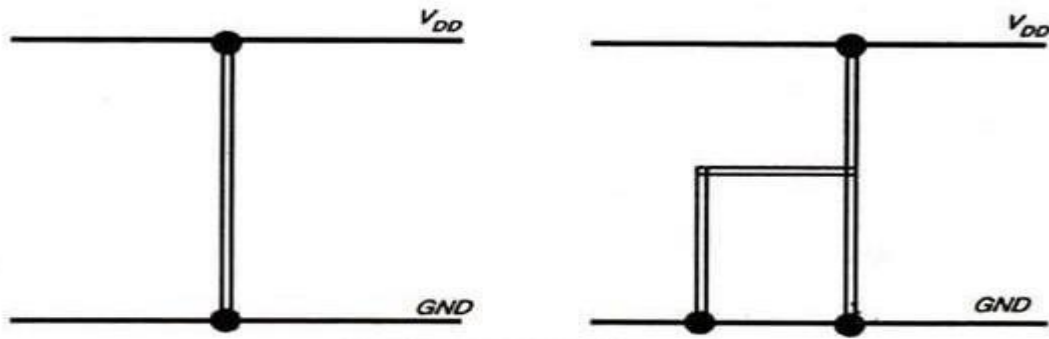

(a) Rails and thinox paths

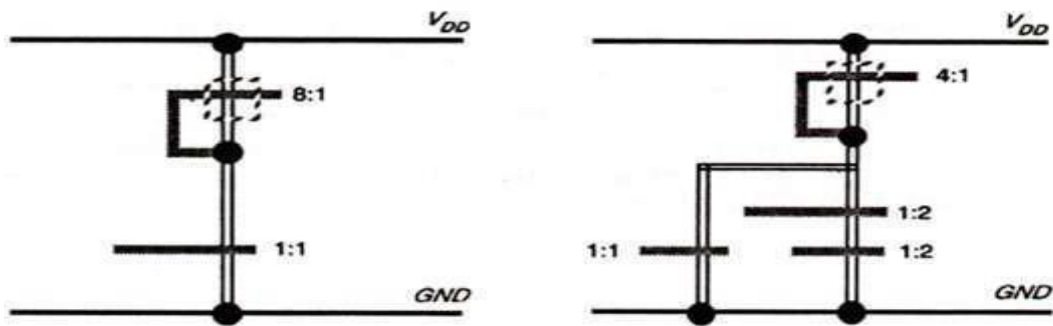

(b) Pull-up and pull-down structures (polysilicon), implants, and ratios

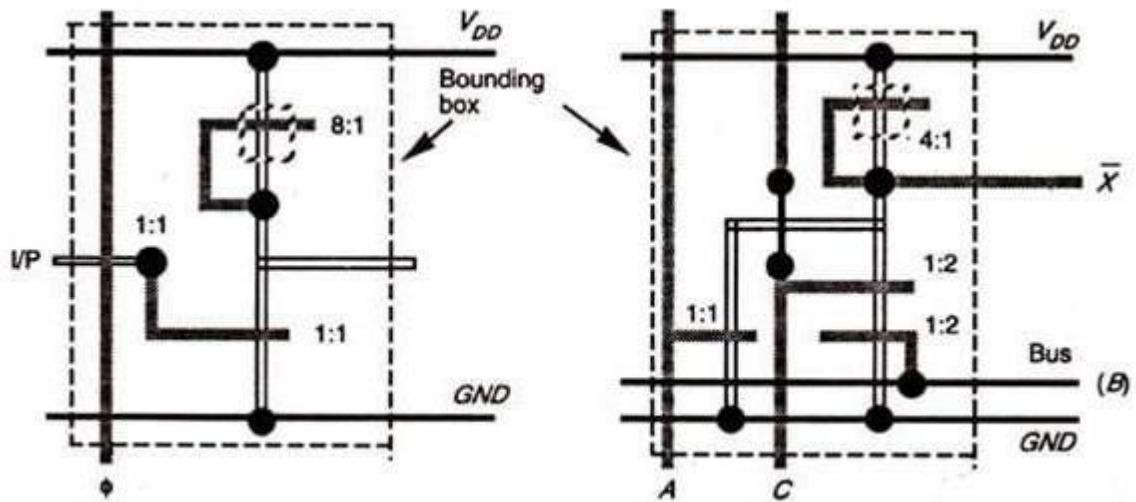

(c) Buses, control signals, interconnections, and 'leaf-cell' boundaries

### CMOS Design Style:

The CMOS design rules are almost similar and extensions of n-MOS design rules except the Implant (yellow) and the buried contact (brown). In CMOS design Yellow is used to identify p transistors and wires, as depletion mode devices are not utilized. The two types of transistors 'n' and 'p', are separated by the demarcation line (representing the p-well boundary) above which all p-type devices are placed (transistors and wires (yellow)). The n-devices (green) are consequently placed below the demarcation line and are thus located in the p-well as shown in the diagram below.

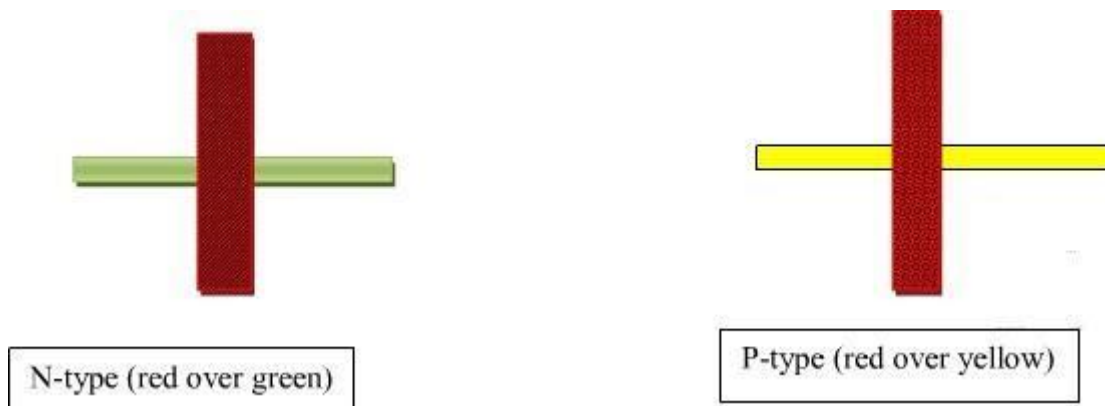

Diffusion paths must not cross the demarcation line and n-diffusion and p-diffusion wires must not join. The 'n' and 'p' features are normally joined by metal where a connection is needed. Their geometry will appear when the stick diagram is translated to a mask layout. However, one must not forget to place crosses on VDD and Vss rails to represent the substrate and p-well connection respectively. The design style is explained by taking the example the design of a single bit shift register. The design begins with the drawing of the VDD and Vss rails in parallel and in metal and the creation of an (imaginary) demarcation line in-between, as shown in Fig. below. The n-transistors are then placed below this line and thus close to Vss, while p-transistors are placed above the line and below VDD. In both cases, the transistors are conveniently placed with their diffusion paths parallel to the rails (horizontal in the diagram) as shown in Fig.(b). A similar approach can be taken with transistors in symbolic form.

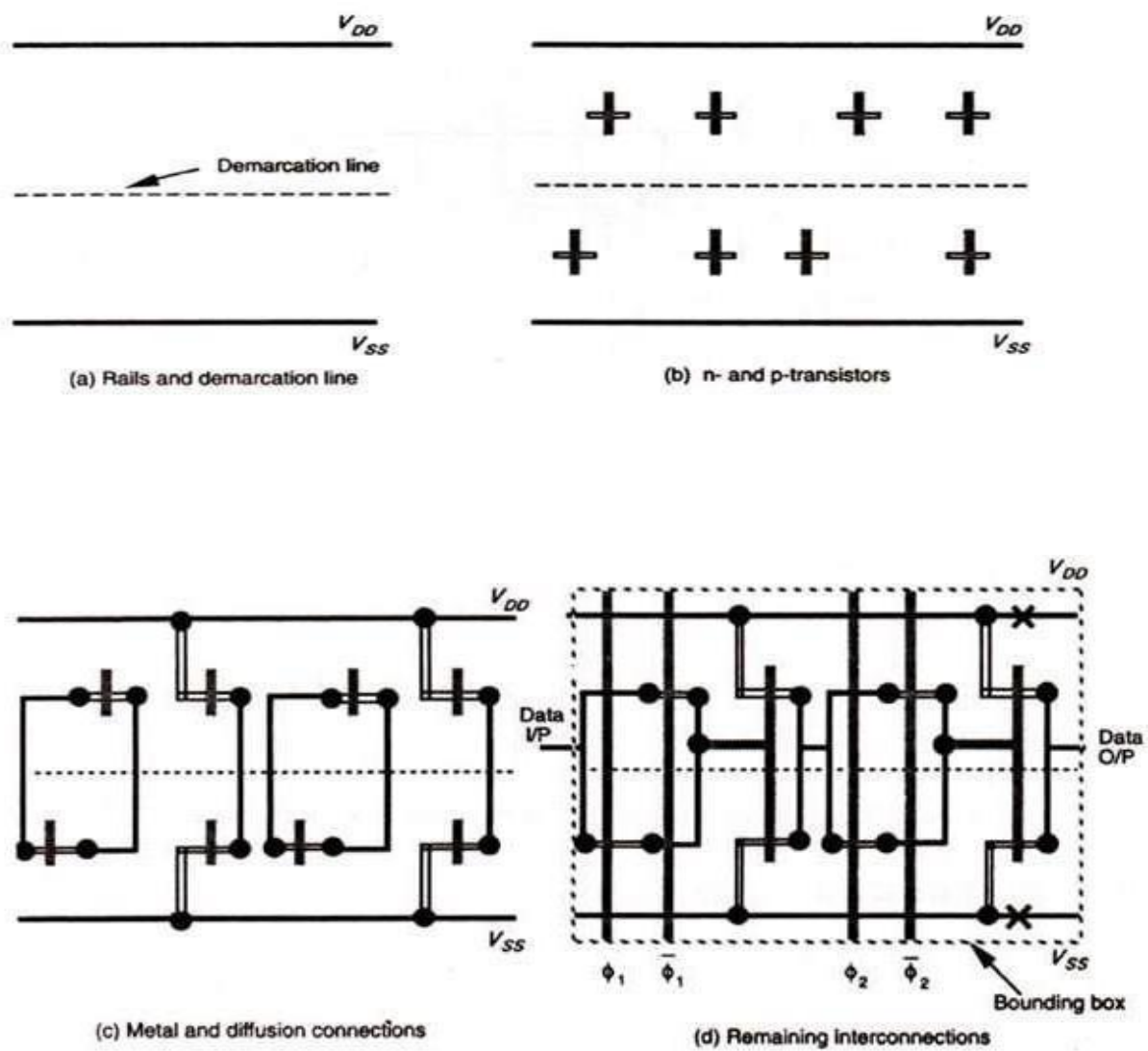

**Fig. CMOS stick layout design style (a,b,c,d)**

The n- along with the p-transistors are interconnected to the rails using the metal and connect as Shown in Fig.(d). It must be remembered that only metal and poly-silicon can cross the demarcation line but with that restriction, wires can run-in diffusion also. Finally, the remaining interconnections are made as appropriate and the control signals and data inputs are added as shown in the Fig.(d).

Stick Diagrams:

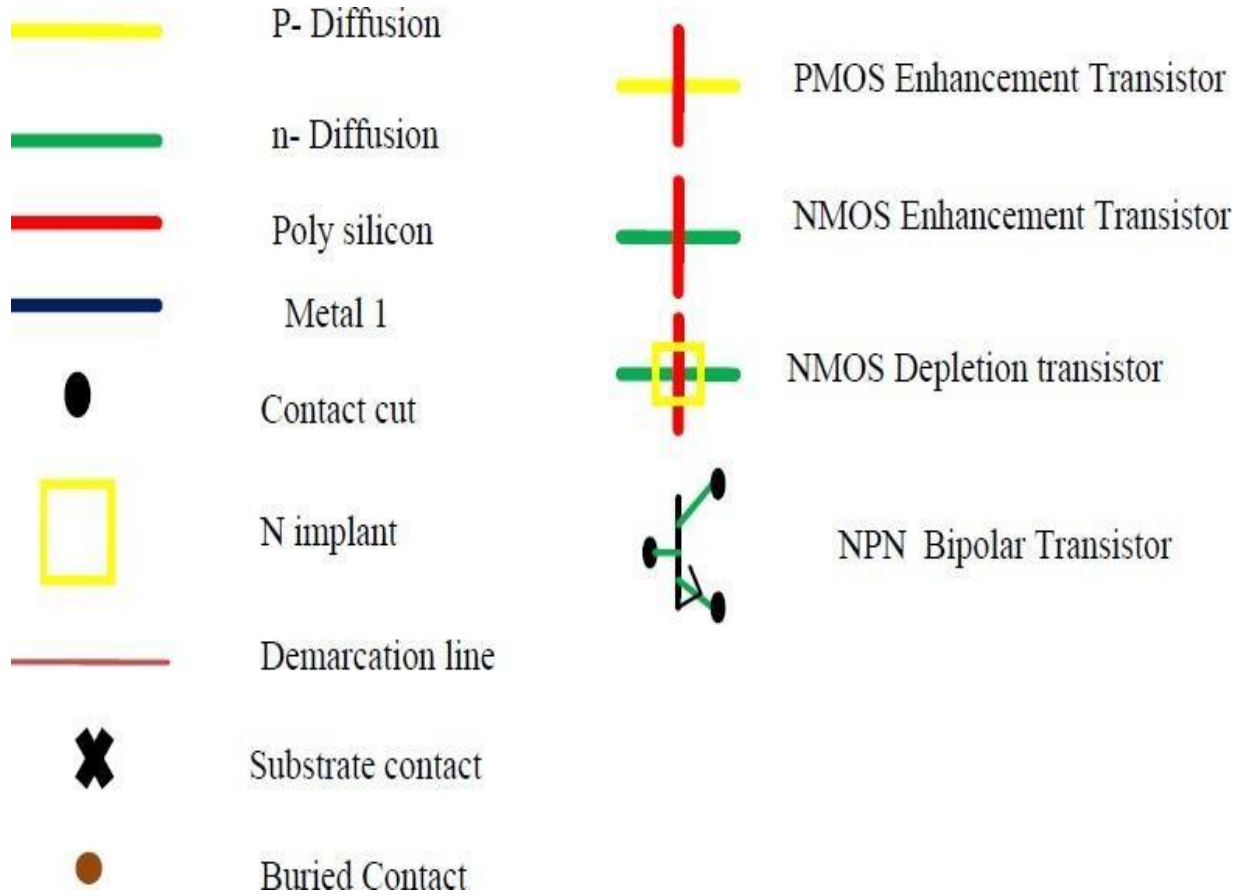

**Examples of Stick Diagrams**

**CMOS Inverter**

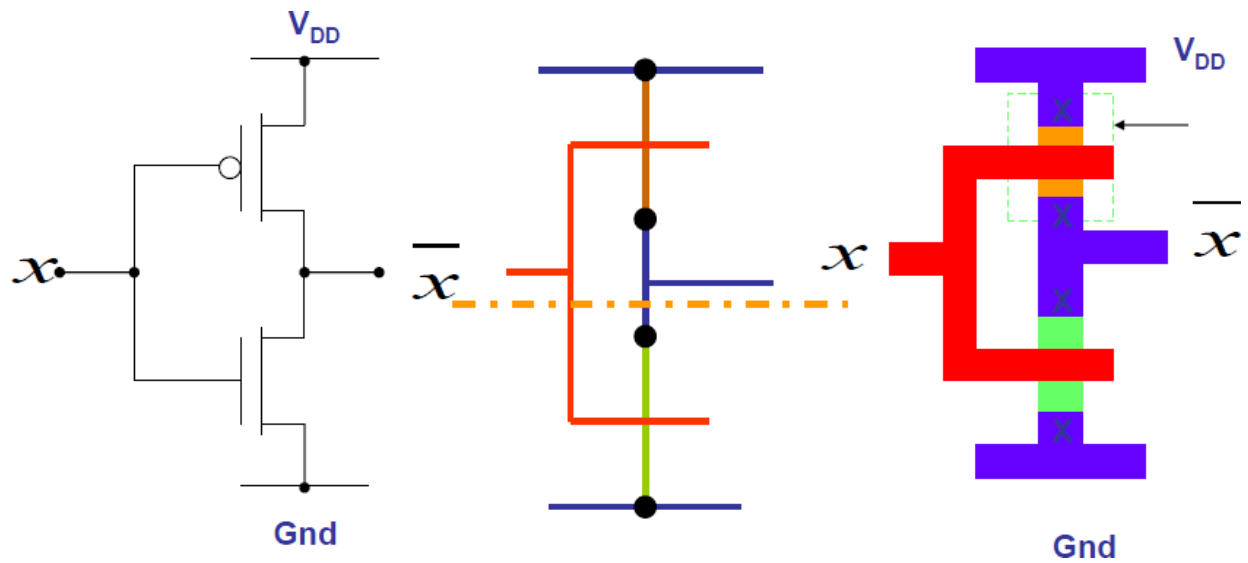
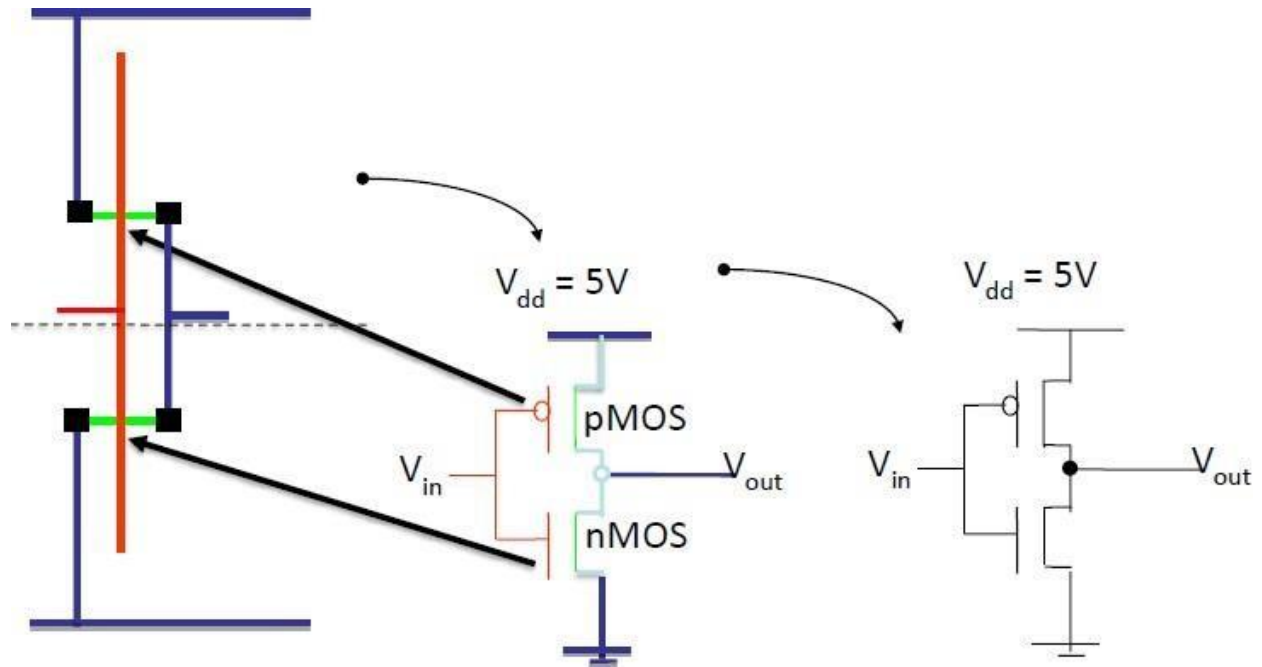

Contd....

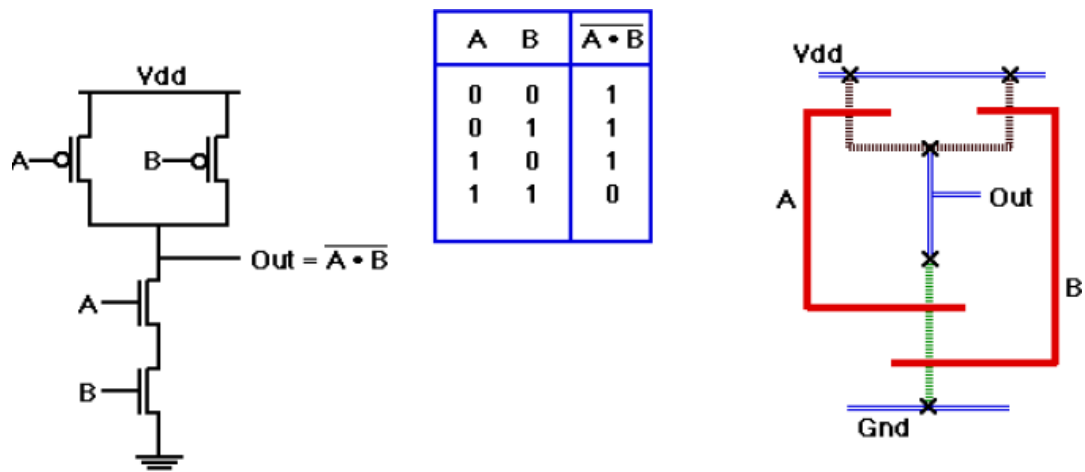

1. Pull-down: Connect to ground If A=1 AND B=1
2. Pull-up: Connect to Vdd If A=0 OR B=0

Fig. CMOS NAND gate

Example:  $f = \overline{(A \cdot B) + C}$

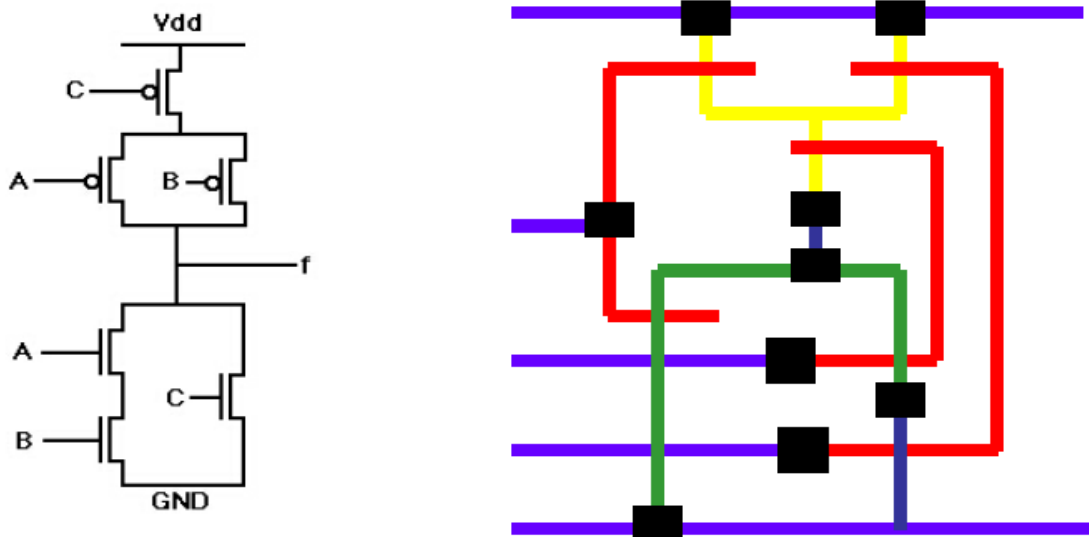

## Design Rules and Layout

In VLSI design, as processes become more and more complex, need for the designer to understand the intricacies of the fabrication process and interpret the relations between the different photo masks is really troublesome. Therefore, a set of layout rules, also called **design rules**, has been defined. They act as an interface or communication link between the circuit designer and the process engineer during the manufacturing phase. The objective associated with layout rules is to obtain a circuit with optimum yield (functional circuits versus non-functional circuits) in as small as area possible without compromising reliability of the circuit. In addition, Design rules can be conservative or aggressive, depending on whether yield or performance is desired. Generally, they are a compromise between the two. Manufacturing processes have their inherent limitations in accuracy. So the need of design rules arises due to manufacturing problems like –

- Photo resist shrinkage, tearing.
- Variations in material deposition, temperature and oxide thickness.
- Impurities.
- Variations across a wafer.

These lead to various problems like :

- **Transistor problems:**

Variations in threshold voltage: This may occur due to variations in oxide thickness, ion-implantation and poly layer. Changes in source/drain diffusion overlap. Variations in substrate.

- **Wiring problems:**

Diffusion: There is variation in doping which results in variations in resistance, capacitance. Poly, metal: Variations in height, width resulting in variations in resistance, capacitance. Shorts and opens.

- **Oxide problems:**

Variations in height.

Lack of planarity.

- **Via problems:**

Via may not be cut all the way through.

Undersize via has too much resistance.

Via may be too large and create short.

To reduce these problems, the design rules specify to the designer certain geometric constraints on the layout artwork so that the patterns on the processed wafers will preserve the topology and geometry of the designs. This consists of minimum-width and minimum-spacing constraints and requirements between objects on the same or different layers. Apart from following a definite set of rules, design rules also come by experience.

### Why we use design rules?

- Interface between designer and process engineer
- Historically, the process technology referred to the length of the silicon channel between the source and drain terminals in field effect transistors.
- The sizes of other features are generally derived as a ratio of the channel length, where some may be larger than the channel size and some smaller.

For example, in a 90 nm process, the length of the channel may be 90 nm, but the width of the gate terminal may be only 50 nm.

<b>Semiconductor manufacturing processes</b>	
■	<u>10 μm</u> — 1971
■	<u>3 μm</u> — 1975
■	<u>1.5 μm</u> — 1982
■	<u>1 μm</u> — 1985
■	<u>800 nm</u> (0.80 μm) — 1989
■	<u>600 nm</u> (0.60 μm) — 1994
■	<u>350 nm</u> (0.35 μm) — 1995
■	<u>250 nm</u> (0.25 μm) — 1998
■	<b>180 nm</b> (0.18 μm) — 1999
■	<u>130 nm</u> (0.13 μm) — 2000
■	<u>90 nm</u> — 2002
■	<u>65 nm</u> — 2006
■	<u>45 nm</u> — 2008
■	<u>32 nm</u> — 2010
■	<u>22 nm</u> — approx. 2011
■	<u>16 nm</u> — approx. 2018
■	<u>11 nm</u> — approx. 2022

Design rules define ranges for features

Examples:

- min. wire widths to avoid breaks
- min. spacing to avoid shorts
- minimum overlaps to ensure complete overlaps
- Measured in microns
- Required for resolution/tolerances of masks

Fabrication processes defined by minimum channel width

- Also minimum width of poly traces
- Defines “how fast” a fabrication process is

### Types of Design Rules

The design rules primary address two issues:

1. The geometrical reproduction of features that can be reproduced by the maskmaking and lithographical process, and
2. The interaction between different layers.

There are primarily two approaches in describing the design rules.

1. Linear scaling is possible only over a limited range of dimensions.
2. Scalable design rules are conservative .This results in over dimensioned and less dense design.
3. This rule is not used in real life.

#### 1. Scalable Design Rules (e.g. SCMOS, $\lambda$ -based design rules):

In this approach, all rules are defined in terms of a single parameter  $\lambda$ . The rules are so chosen that a design can be easily ported over a cross section of industrial process ,making the layout portable .Scaling can be easily done by simply changing the value of.

The key disadvantages of this approach are:

#### 2. Absolute Design Rules (e.g. $\mu$ -based design rules ) :

In this approach, the design rules are expressed in absolute dimensions (e.g.  $0.75\mu\text{m}$ ) and therefore can exploit the features of a given process to a maximum degree. Here, scaling and porting is more demanding, and has to be performed either manually or using CAD tools .Also, these rules tend to be more complex especially for deep submicron.

The fundamental unity in the definition of a set of design rules is the minimum line width .It stands for the minimum mask dimension that can be safely transferred to the semiconductor material .Even for the same minimum dimension, design rules tend to differ from company to company, and from process to process. Now, CAD tools allow designs to migrate between compatible processes.

### **LAMBDA-BASED DESIGN RULES:-**

- *Lambda-based* (scalable CMOS) design rules define scalable rules based on  $\lambda$  (which is half of the minimum channel length)
  - classes of MOSIS SCMOS rules: SUBMICRON, DEEPSUBMICRON
- Stick diagram is a draft of real layout, it serves as an abstract view between the schematic and layout.
- Circuit designer in general want tighter, smaller layouts for improved performance and decreased silicon area.
- On the other hand, the process engineer wants design rules that result in a controllable and reproducible process.
- Generally we find there has to be a compromise for a competitive circuit to be produced at a reasonable cost.
- All widths, spacing, and distances are written in the form
- $\lambda = 0.5 \times$  minimum drawn transistor length
- Design rules based on single parameter,  $\lambda$
- Simple for the designer
- Wide acceptance
- Provide feature size independent way of setting outmask
- If design rules are obeyed, masks will produce working circuits
- Minimum feature size is defined as  $2 \lambda$
- Used to preserve topological features on a chip
- Prevents shorting, opens, contacts from slipping out of area to be contacted

# LAMBDA BASED RULES

## MINIMUM WIDTH AND SPACING RULES

LAYER	TYPE OF RULE	VALUE
POLY	Minimum Width	$2\lambda$
	Minimum Spacing	$2\lambda$
N/P DIFFUSION	Minimum Width	$3\lambda$
	Minimum Spacing	$3\lambda$
N-WELL	Minimum Width	$3\lambda$
	Minimum Spacing	$3\lambda$
P-WELL	Minimum Width	$3\lambda$
	Minimum Spacing	$3\lambda$
METAL1	Minimum Width	$3\lambda$
	Minimum Spacing	$3\lambda$

### DESIGN RULES FOR WIRES (nMOS and CMOS)

Design rules and layout methodology based on the concept of  $\lambda$  provide a process and feature size independent way of setting out mask dimensions to scale. All paths in layers are dimensioned in  $\lambda$  units and subsequently  $\lambda$  can be allocated an appropriate value compatible with the feature size of the fabrication process.

Minimum width specified)

minimum separation (where

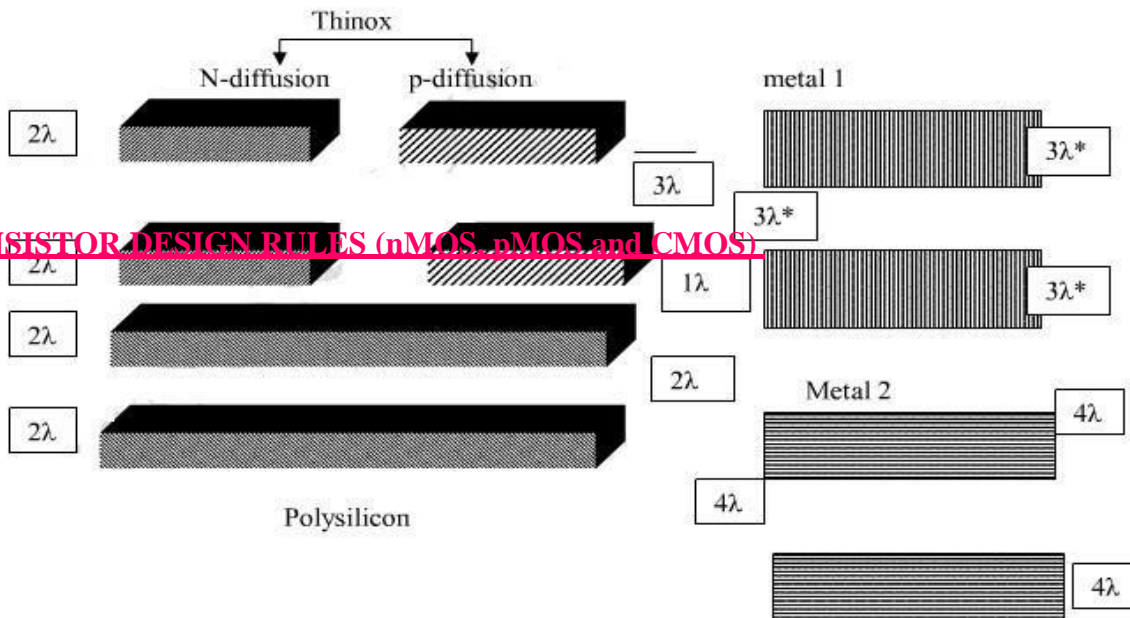

### TRANSISTOR DESIGN RULES (nMOS, pMOS and CMOS)

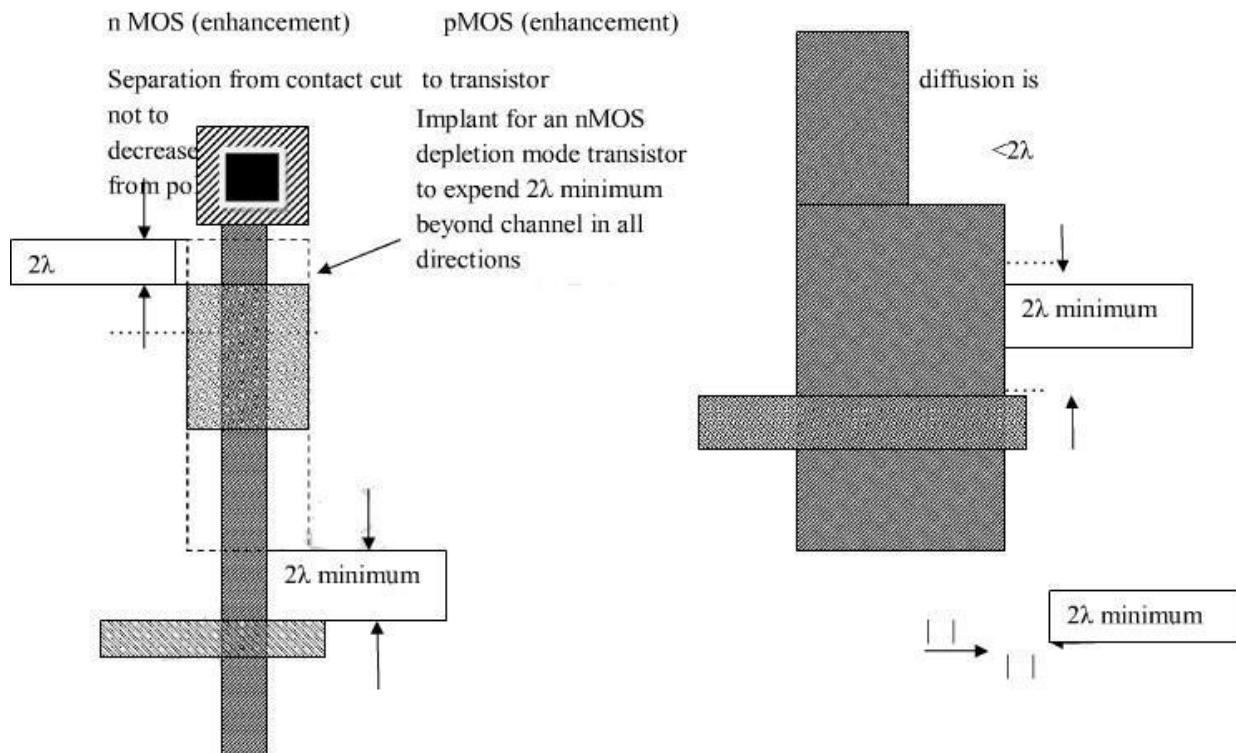
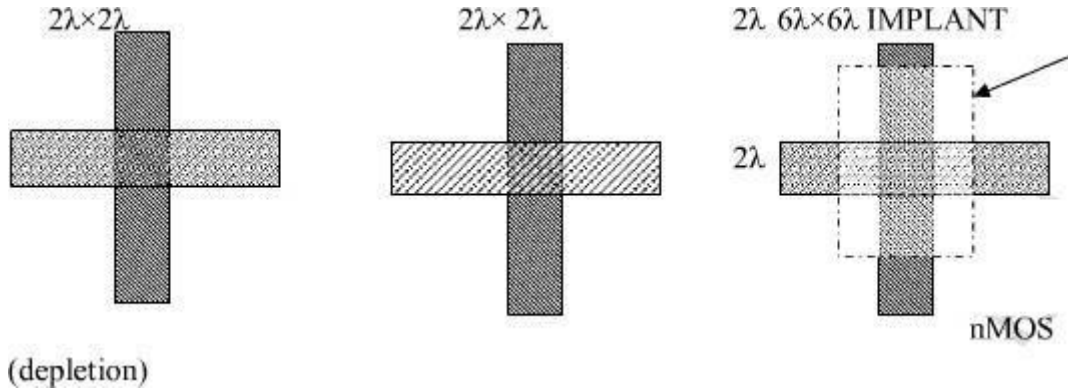

polysilicon to extend a minimum of 2λ beyond diffusion boundaries (width constant)

Separation from implant to another transistor

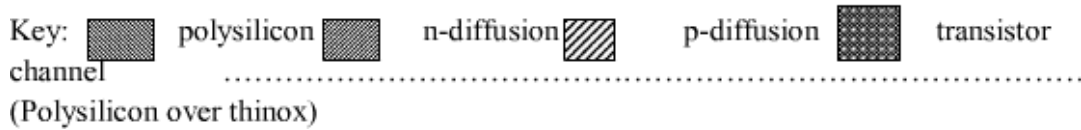

metal 1 to polysilicon or to diffusion

$3\lambda$  minimum



cuts

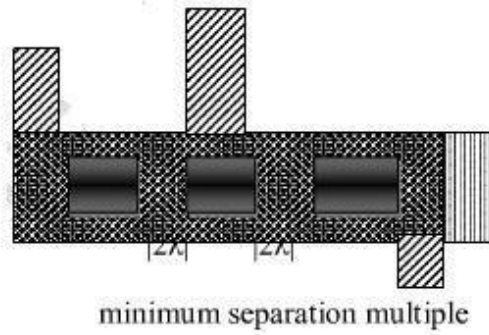
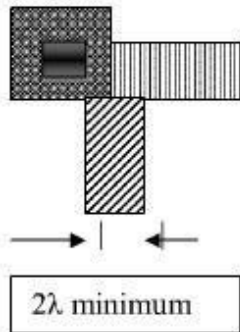

$2\lambda \times 2\lambda$  cut centered on  $4\lambda \times 4\lambda$  superimposed area of layers to be joined in all cases

$2\lambda$  minimum separation (if other spacing's allowed)

Metal 2

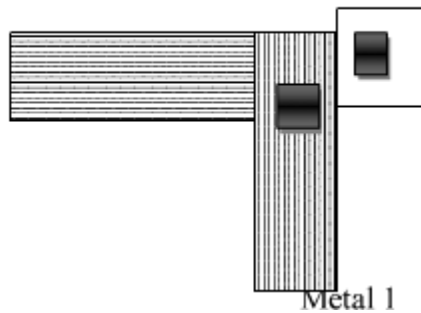

$4\lambda \times 4\lambda$  area of overlap with  
 $2\lambda \times 2\lambda$  via at center

Via and cut used to connect metal 2 to diffusion

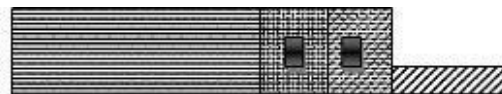

Via cut

Contacts (nMOS and CMOS)

## **CONTACT CUTS**

When making contacts between poly-silicon and diffusion in nMOS circuits it should be remembered that there are three possible approaches--poly. to metal then metal to diff., or a buried contact poly. to diff. , or a butting contact (poly. to diff. using metal). Among the three the latter two, the buried contact is the most widely used, because of advantage in space and a reliable contact. At one time butting contacts were widely used , but now a days they are superseded by buried contacts.

In CMOS designs, poly. to diff. contacts are always made via metal. A simple process is followed for making connections between metal and either of the other two layers (as in Fig.a), The  $2\lambda. \times 2\lambda.$  contact cut indicates an area in which the oxide is to be removed down to the underlying polysilicon or diffusion surface. When deposition of the metal layer takes place the metal is deposited through the contact cut areas onto the underlying area so that contact is made between the layers.

The process is more complex for connecting diffusion to poly-silicon using the butting contact approach (Fig.b), In effect, a  $2\lambda. \times 2\lambda.$  contact cut is made down to each of the layers to be joined. The layers are butted together in such a way that these two contact cuts become contiguous. Since the poly-silicon and diffusion outlines overlap and thin oxide under poly silicon acts as a mask in the diffusion process, the poly-silicon and diffusion layers are also butted together. The contact between the two butting layers is then made by a metal overlay as shown in the Fig.

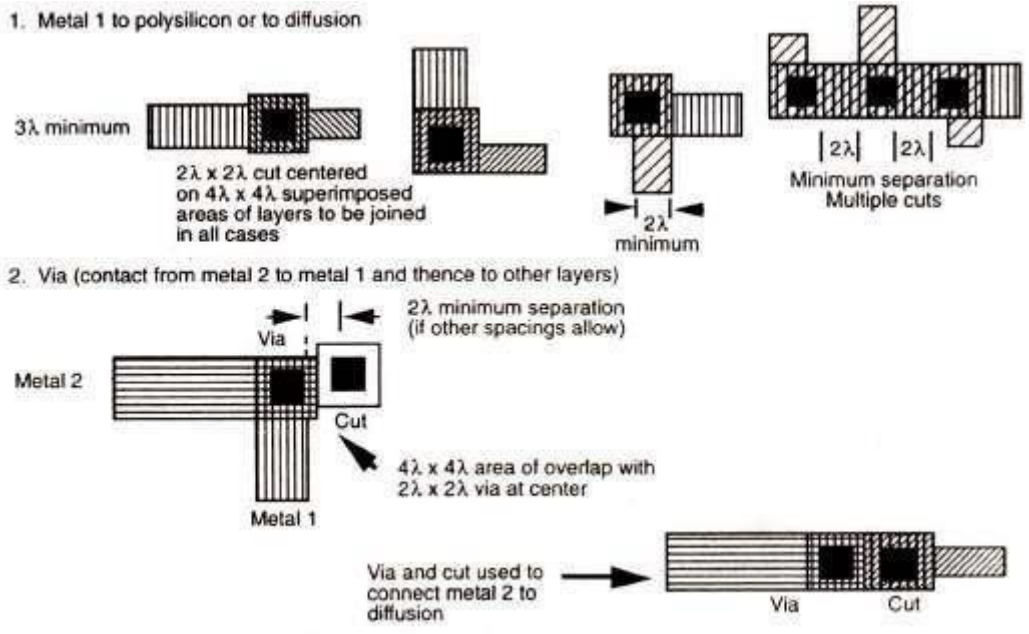

Fig.(a) . n-MOS & C-MOS Contacts

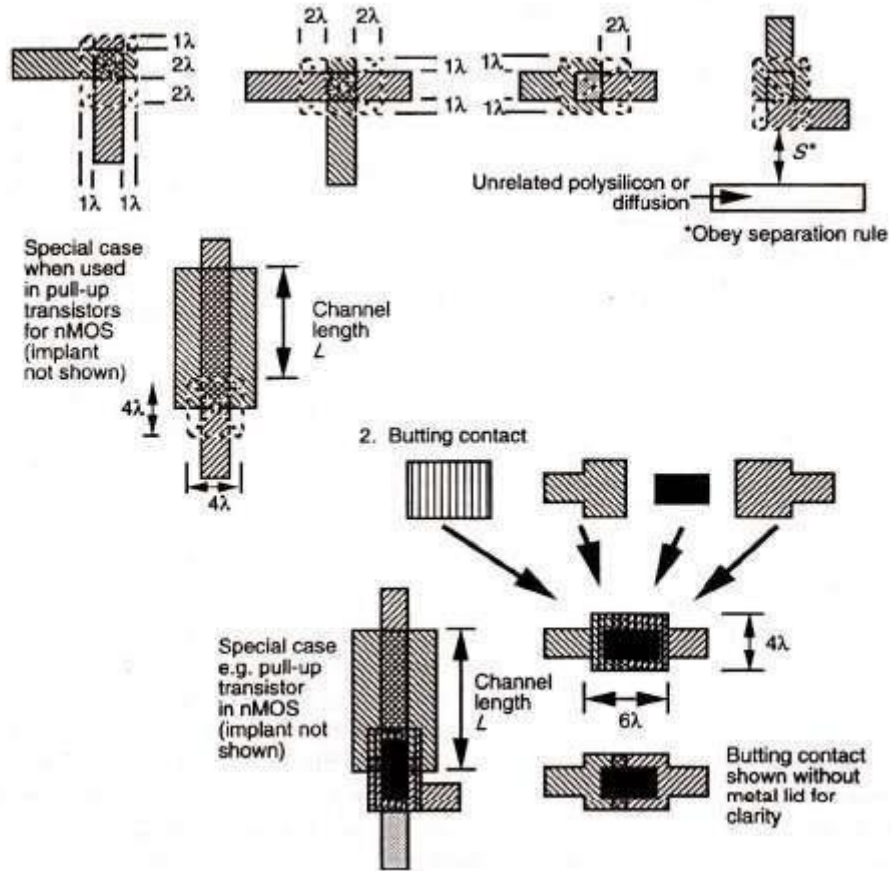

Fig.(b). Contacts poly-silicon to diffusion

In buried contact basically, layers are joined over a  $2\lambda \times 2\lambda$  area with the buried contact cut extending by  $1\lambda$ , in all directions around the contact area except that the contact cut extension is increased to  $2\lambda$  in diffusion paths leaving the contact area. This helps to avoid the formation of unwanted transistors. So this buried contact approach is simpler when compared to others. The poly-silicon is deposited directly on the underlying crystalline wafer. When diffusion takes place, impurities will diffuse into the poly-silicon as well as into the diffusion region within the contact area. Thus a satisfactory connection between poly-silicon and diffusion is ensured. Buried contacts can be smaller in area than their butting contact counterparts and, since they use no metal layer, they are subject to fewer design rule restrictions in a layout.

### Other design rules

- Double Metal MOS process Rules
- CMOS fabrication is much more complex than nMOS fabrication
- 2um Double metal, Double poly. CMOS/BiCMOS Rules
- 1.2um Double Metal single poly. CMOS rules

### CMOS Lambda-based Design Rules:

The CMOS fabrication process is more complex than nMOS fabrication. In a CMOS process, there are nearly 100 actual set of industrial design rules. The additional rules are concerned with those features unique to p-well CMOS, such as the p-well and p+ mask and the special 'substrate contacts'. The p-well rules are shown in the diagram below

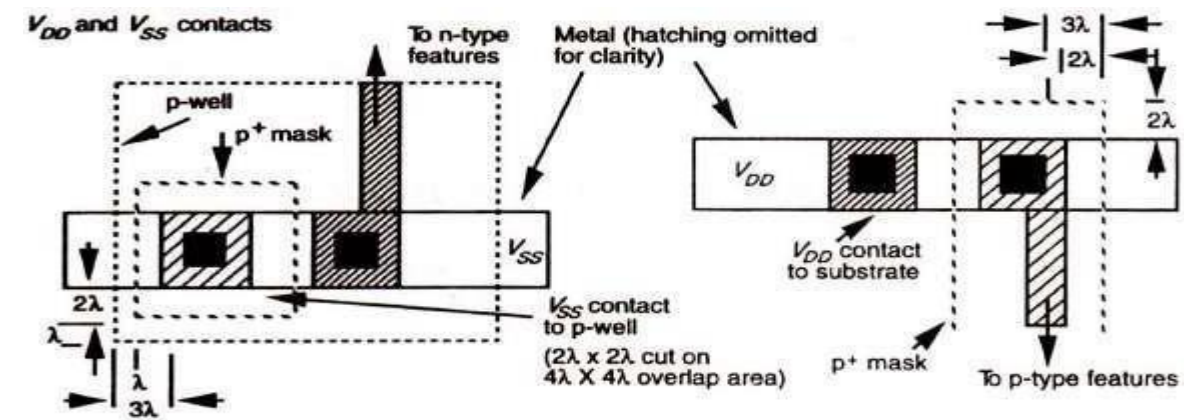

In the diagram above each of the arrangements can be merged into single split contacts.

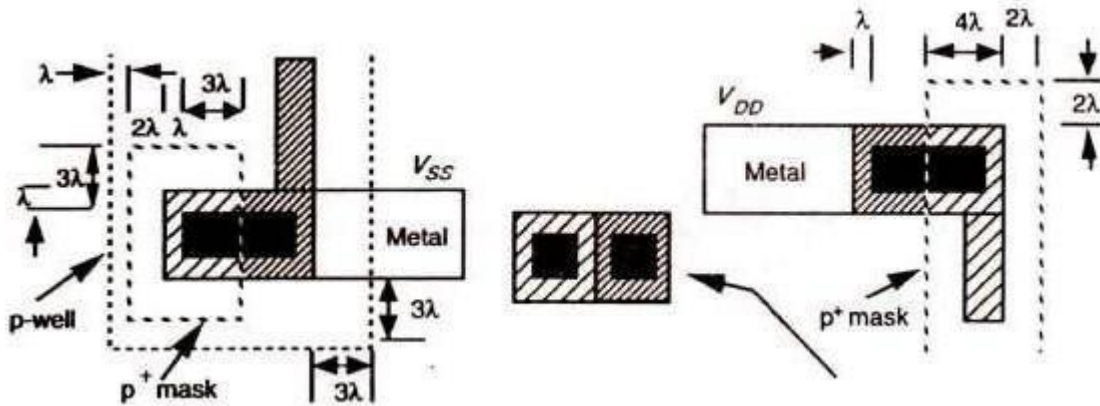

From the above diagram it is also clear that split contacts may also be made with separate cuts.

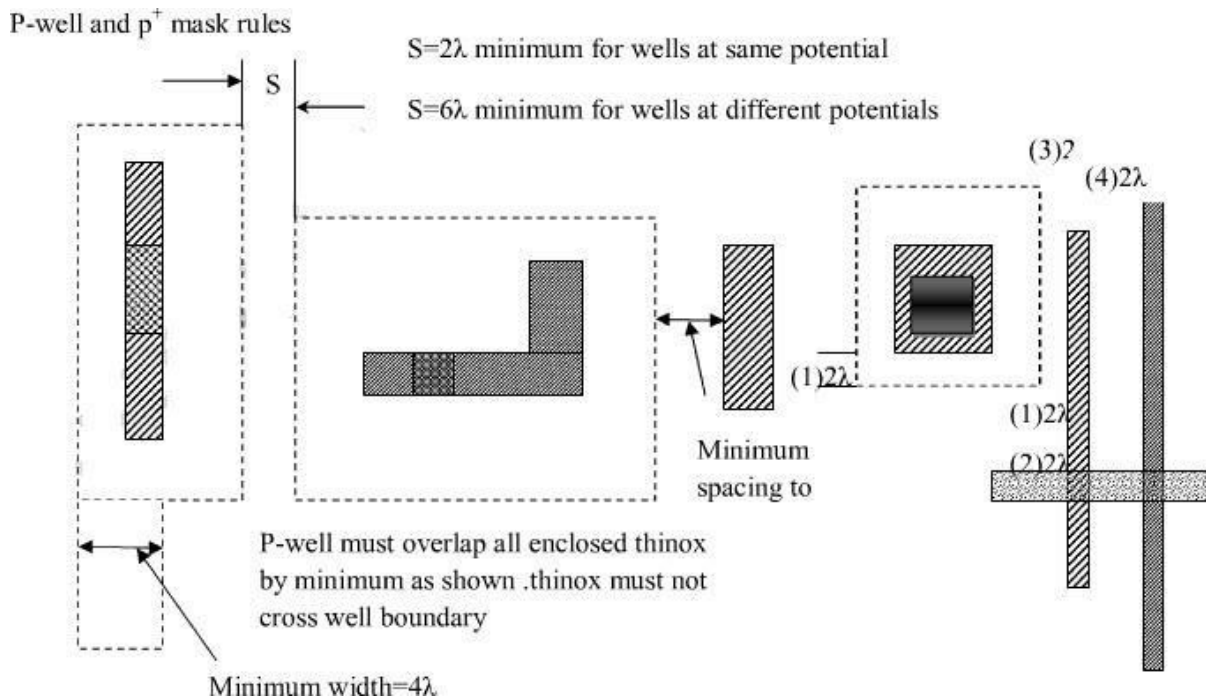

The CMOS rules are designed based on the extensions of the Mead and Conway concepts and also by excluding the butting and buried contacts the new rules for CMOS design are formed. These rules for CMOS design are implemented in the above diagrams.

**1μM CMOS Design rules**

The encoding is compatible with that already described where as following extension are made: n-well brown →

Poly 1 → red; poly 2 → orange; diff (n-active) → green; p Diff (p-active) → yellow.

For BiCMOS the following are added: buried n<sup>+</sup> sub collector- pale green; p-base--pink.

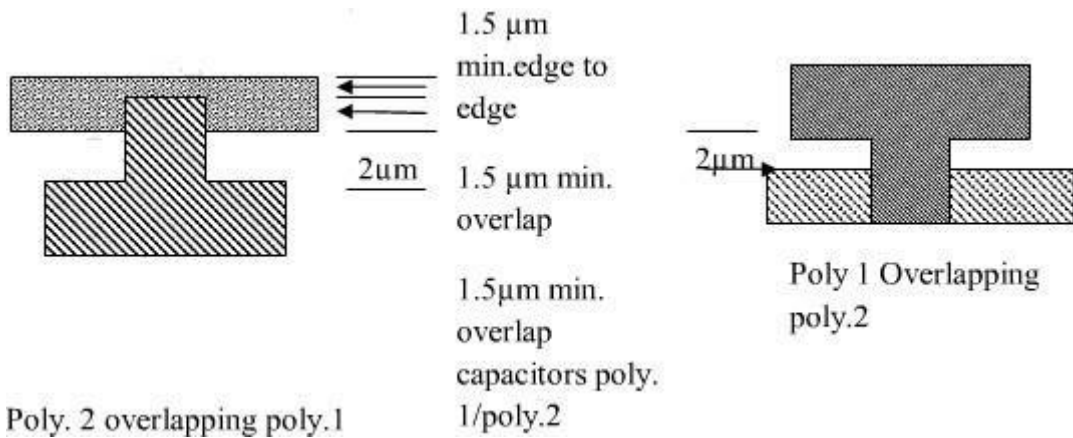
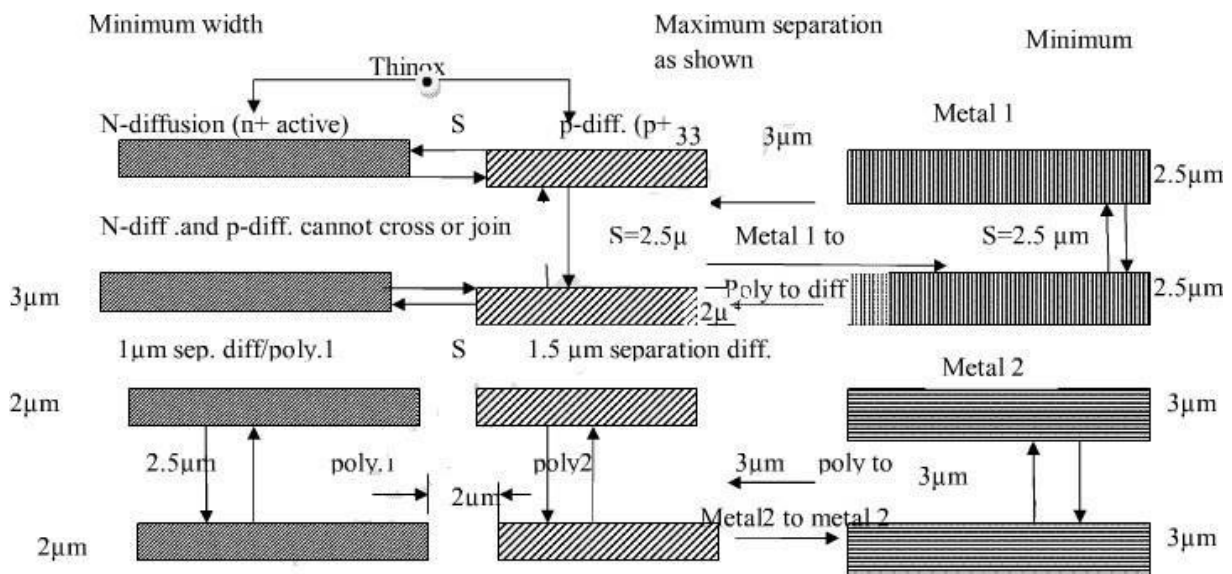

AVOID COINCIDENT EDGES WHERE METAL 1 AND METAL 2 RUNS FOLLOW THE SAME PATH FOR >25μm LENGTH (UNDER LAP METAL 1)

Design rules for wires (interconnects) (orbit 2µm CMOS)

**2µm DOUBLE METAL, SINGLE POLY CMOS RULES**

The orbit™ 1.2µm rules provide improved feature size. A separate set of micro based design rules accompany them

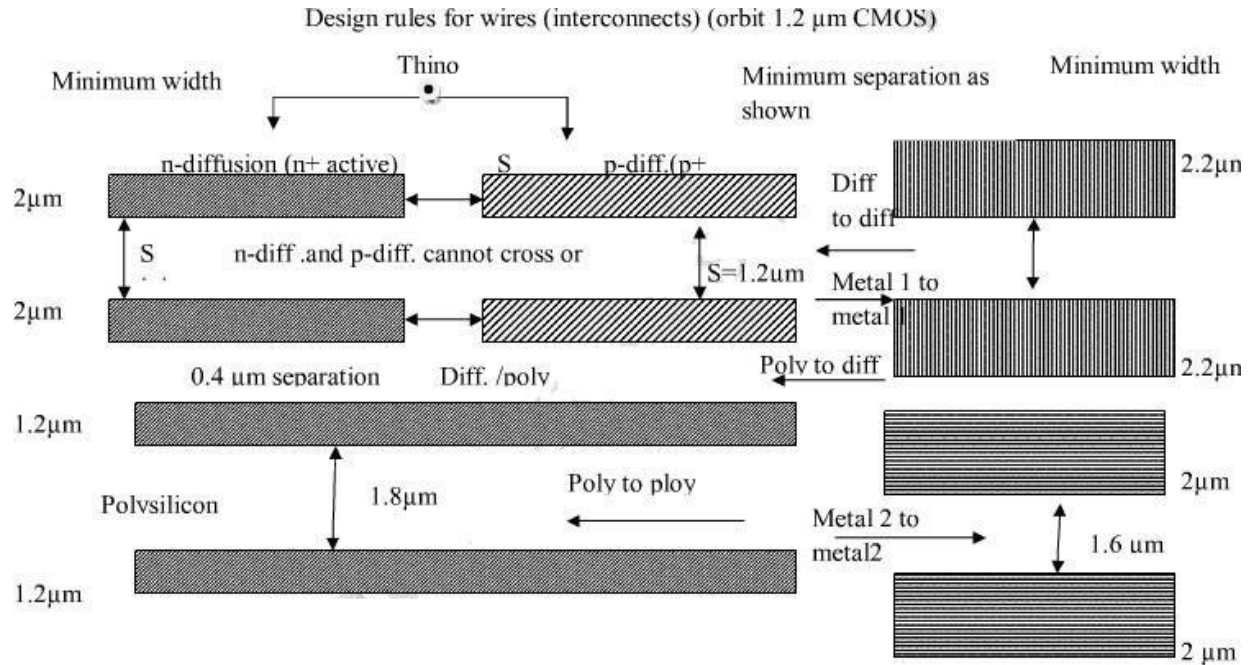

Avoid coincident edges where metal 1 and metal2 runs follow the same path for >25µm length (under lap metal 1 edges by 0.8 µm).

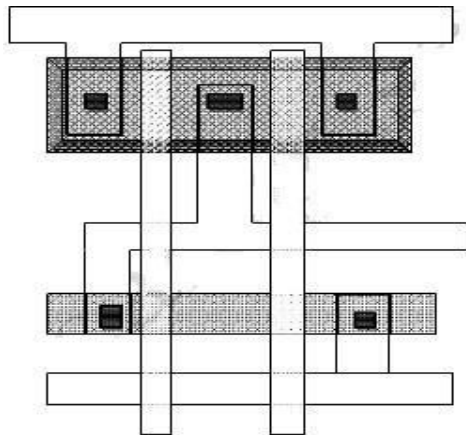

N-WELL AND ACTIVE AREA MASKS  
AND ...  
.....PMOS  
TRANSISTORS

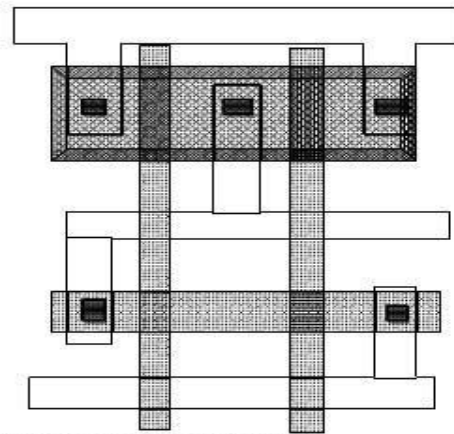

POLY MASK -> DEFINE NMOS  
.....PMOS

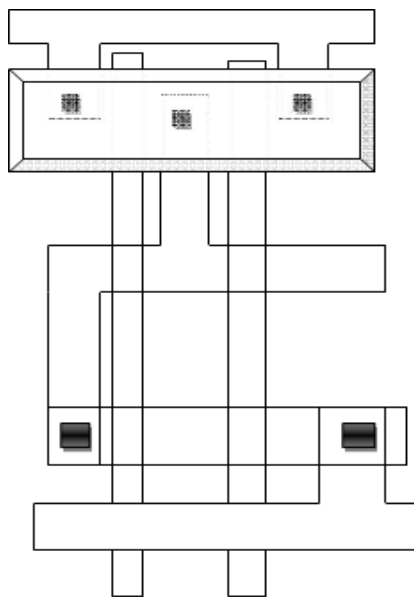

Metal mask for  $V_{DD}$ , GND and output connections

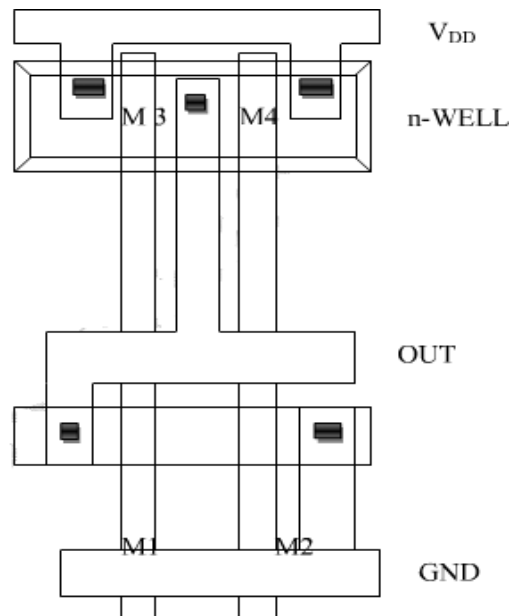

$V_A$   $V_B$   
METAL-DIFFUSION  
CONSTANT MASK

## Layout Diagrams for NMOS and CMOS Inverters and Gates

### Layer Types

- p-substrate
- n-well
- n<sup>+</sup>
- p<sup>+</sup>
- Gate oxide
- Gate (polysilicon)
- Field Oxide
  - Insulated glass
  - Provide electrical isolation

### Basic Gate Design

Both the power supply and ground are routed using the Metal layer

n<sup>+</sup> and p<sup>+</sup> regions are denoted using the same fill pattern. The only difference is the n-well

Contacts are needed from Metal to n<sup>+</sup> or p<sup>+</sup>

## The CMOS NOT Gate

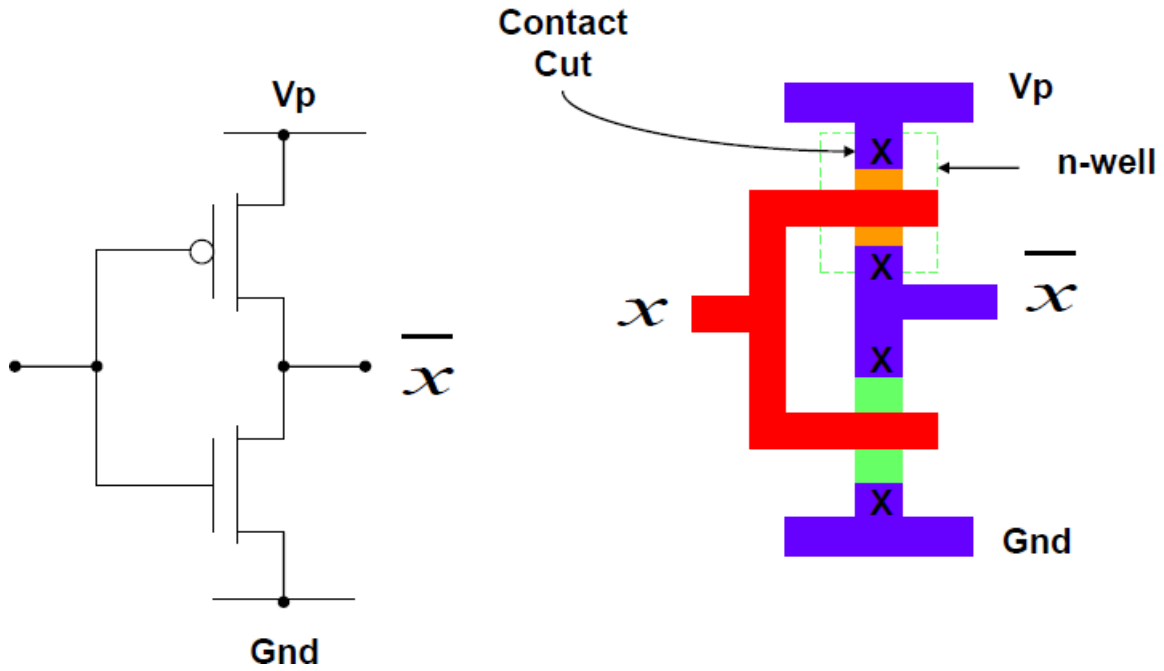

## The CMOS NAND Gate

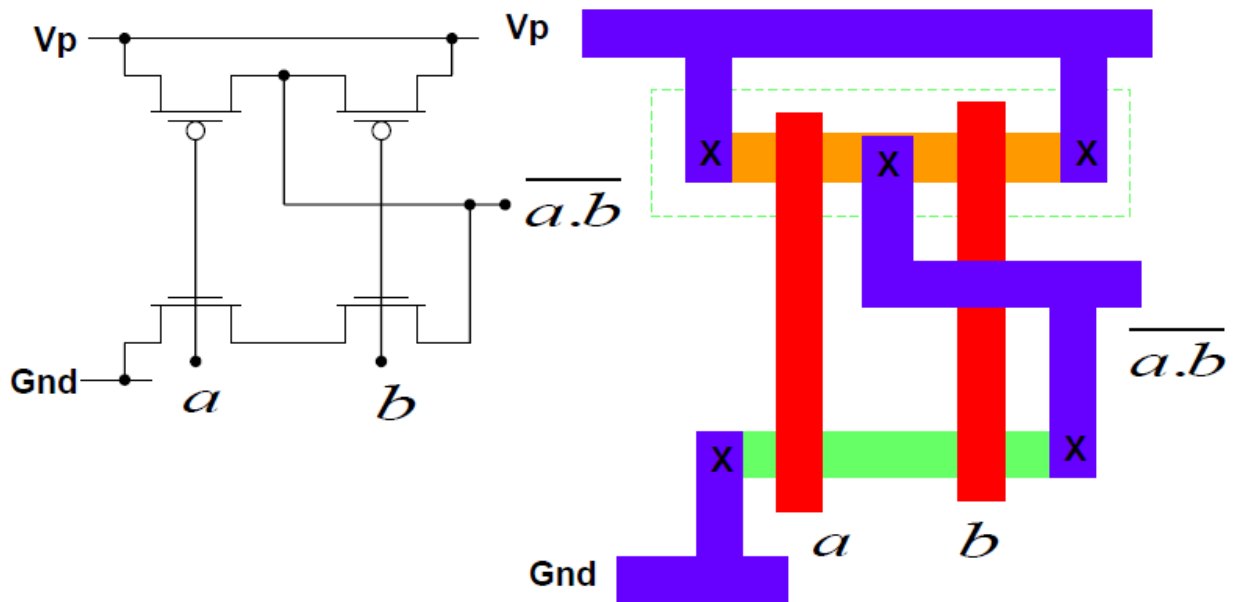

Layout & Stick Diagram of CMOS Inverter

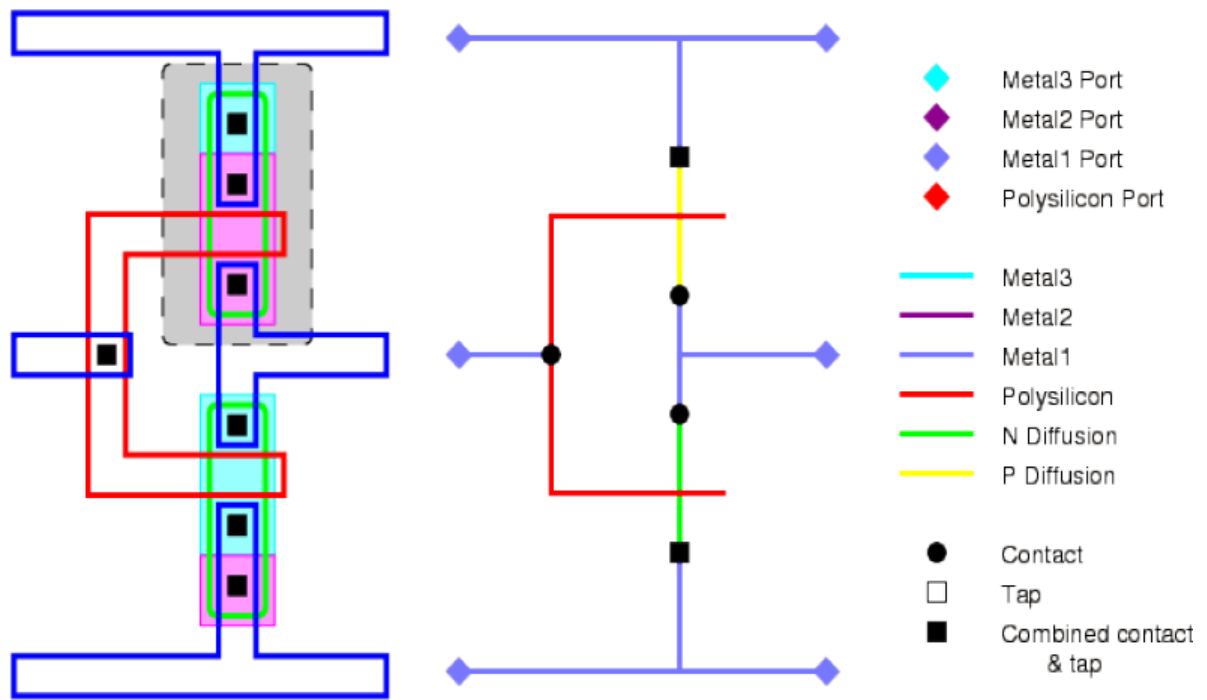

2 input NAND gate

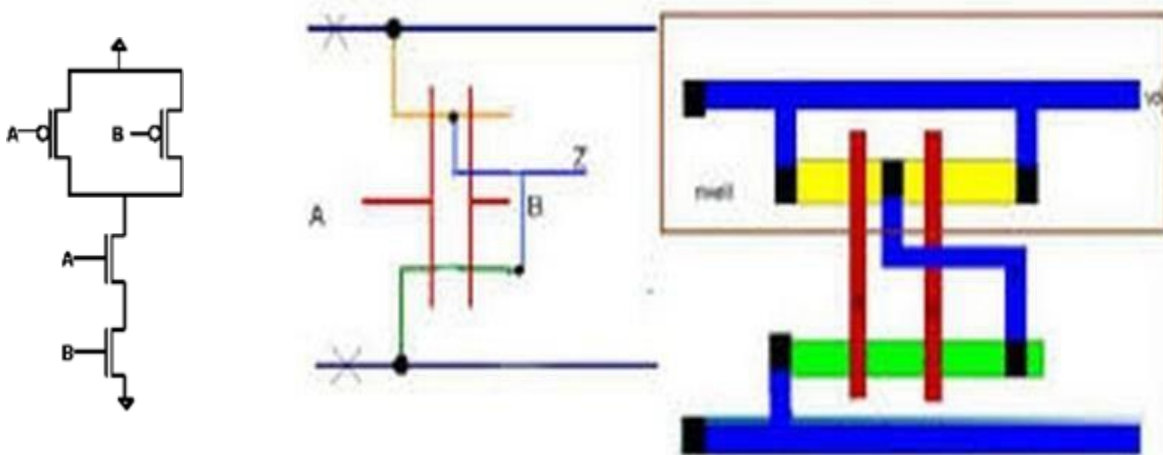

## 2 input NOR gate

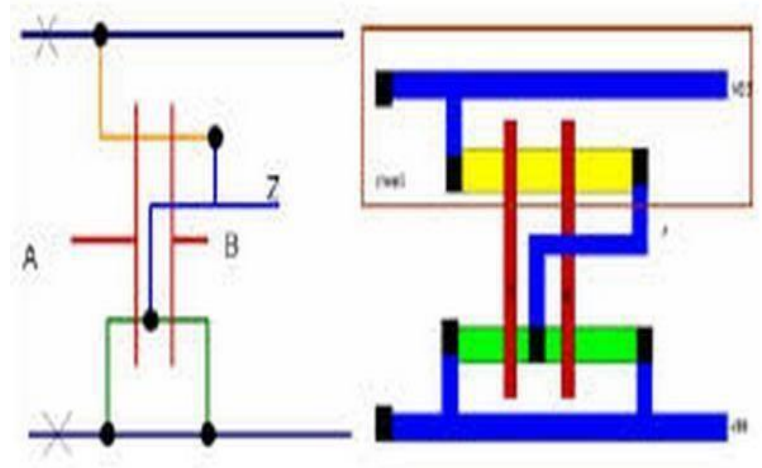
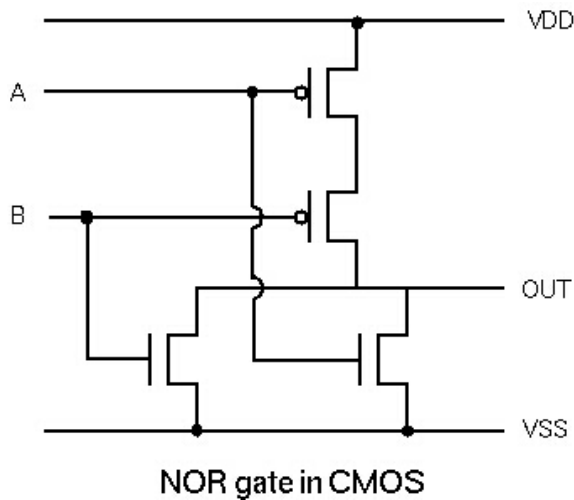

## Scaling of MOS circuits

Scaling means to reduce the feature size and to achieve higher packing density of circuitry on a chip. Many figures of merit such as minimum feature size, number of gates on one chip, power dissipation, maximum operational frequency, die size, production cost can be improved by shrinking the dimensions of transistors, interconnections and the separation between features, and by adjusting the doping levels and supply voltages.

## **SCALING MODELS AND SCALING FACTORS:**

The most commonly used models are the constant electric field scaling models and the constant voltage scaling model. One more model called as combined voltage and dimension scaling model is presented recently. The following figure indicates the device dimensions and substrate doping level which are associated with the scaling of a transistor.

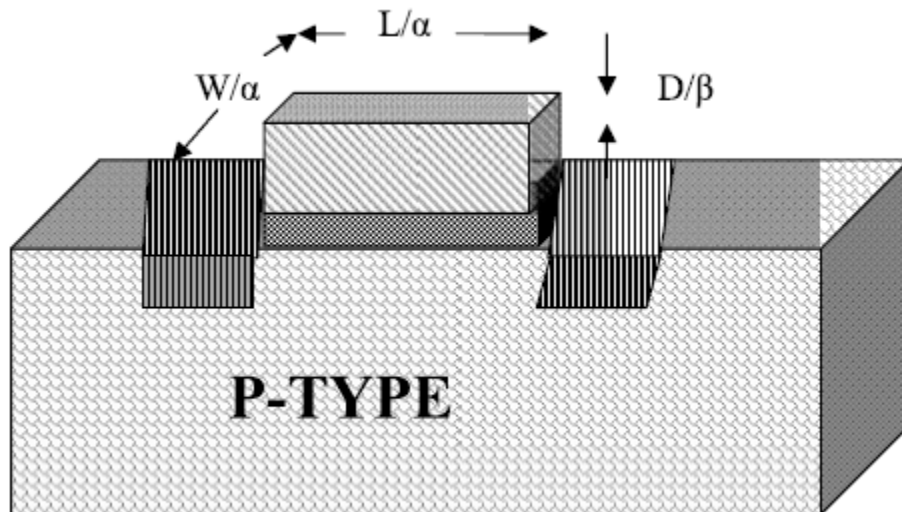

Two scaling factors  $1/\alpha, 1/\beta$  are used.  $1/\beta$  is chosen as the scaling factor for supply voltage  $V_{DD}$  and gate oxide thickness  $D$ , and  $1/\alpha$  is used for all other linear dimensions, both vertical and horizontal to chip surface.

### SCALING FACTORS FOR DEVICE PARAMETERS:

#### GATE AREA $A_g$ :

$$A_g = L \cdot W$$

Where  $L$  and  $W$  are the channel length and width respectively, both are scaled by  $1/\alpha$ . So  $A_g$  is scaled by  $1/\alpha^2$

#### GATE CAPACITANCE PER UNIT AREA $C_o$ OR $C_{ox}$ :

$$C_o = \epsilon_{ox} / D$$

Where  $\epsilon_{ox}$  is the permittivity of the gate oxide (thinox) ( $=\epsilon_{ins} \cdot \epsilon_o$ ) and  $D$  is the gate oxide thickness which is scaled by  $1/\beta$

Thus  $C_o$  is scaled by  $1/1/\beta = \beta$

#### GATE CAPACITANCE $C_g$ :

$$C_g = C_o \cdot L \cdot W$$

Thus  $C_g$  is scaled by  $\beta \cdot 1/\alpha^2 = \beta/\alpha^2$

**PARASITIC CAPACITANCE  $C_X$ :**

$C_X$  is proportional to  $A_X/d$ .

Where  $d$  is the depletion width around source or drain which is scaled by  $1/\alpha$  and  $A_X$  is the area of depletion region around source or drain which is scaled by  $1/\alpha^2$ .  $1/1/\alpha = 1/\alpha$

**CARRIER DENSITY IN CHANNEL  $Q_{on}$** 

$$Q_{on} = C_o \cdot V_{gs}$$

Where  $Q_{on}$  is the average charge per unit area in the channel in the 'on' state.  $C_o$  is scaled by  $\beta$  and  $V_{gs}$  is scaled by  $1/\beta$ .

Thus  $Q_{on}$  is scaled by 1.

**CHANNEL RESISTANCE  $R_{on}$** 

$$R_{on} = L/W \cdot Q_{on} \cdot \mu$$

Where  $\mu$  is the carrier mobility in the channel and is assumed constant. Thus  $R_{on}$  is scaled by  $1/\alpha$ .  $1/1/\alpha = 1$ .

**GATE DELAY  $T_d$** 

$T_d$  is proportional to  $R_{on} \cdot C_g$ .

Thus  $T_d$  is scaled by  $\beta^2/\alpha^4$

**MAXIMUM OPERATING FREQUENCY  $F_o$ :**

$$F_o = W/L \cdot \mu C_o V_{DD} / C_g$$

Or  $f_o$  is inversely proportional to delay  $T_d$ . Thus  $f_o$  is scaled by  $1/\beta/\alpha^2 = \alpha^2/\beta$

**SATURATION CURRENT  $I_{dss}$ :**

$$I_{dss} = C_o \mu / 2 \cdot W/L \cdot (V_{gs} - V_t)^2$$

Nothing that both  $V_{gs}$  and  $V_t$  are scaled by  $1/\beta$ , we have  $I_{dss}$  is scaled by  $\beta(1/\beta)^2 = 1/\beta$ .

**CURRENT DENSITY J:**

$$J = I_{des}/A$$

Where A is the cross sectional area of the channel in the 'on' state which is scaled by  $1/\alpha^2$

So, J is scaled by  $1/\beta/1/\alpha^2 = \alpha^2/\beta$ .

**SWITCHING ENERGY PER GATE  $E_g$ :**

$$E_g = C_g/2 \cdot (V_{DD})^2$$

So  $E_g$  is scaled by  $\beta/\alpha^2 \cdot 1/\beta^2 = 1/\alpha^2\beta$

**POWER DISSIPATION PER GATE  $P_g$ :**

$P_g$  comprise two components such that

$$P_g = P_{gs} + P_d$$

Where the static component

$$P_{gs} = (V_{DD})^2/R_{on}$$

And the dynamic component

$$P_{gd} = E_g f_o$$

It will be seen that both  $P_{gs}$  and  $P_{gd}$  are scaled by  $1/\beta^2$

**POWER DISSIPATION PER UNIT AREA:**

$$P_a = P_g / A_g$$

So  $P_a$  is scaled by  $1/\beta^2 / 1/\alpha^2 = \alpha^2/\beta^2$

**POWER-SPEED PRODUCT  $P_T$ :**

$$P_T = P_g \cdot T_d$$

So  $P_T$  is scaled by  $1/\beta^2 \cdot \beta/\alpha^2 = 1/\alpha^2 \beta$

**Limitations of Scaling:**

Scaling may cause a problem which prevents further miniaturization.

**Substrate doping: -**

The built-in (junction) potential  $V_B$ , is small compared with  $V_{DD}$ .

(a) Substrate doping scaling factors:

As the channel length of a MOS transistor is reduced, the depletion region widths must also be scaled down to prevent the source and drain depletion regions

$N_B$  is thus maintained at a satisfactory level in the channel region and thus problem is reduced. But depletion width  $d$  and built in potential  $V_B$  will impose limitations on scaling.

$$\text{We have } E_{\max} = 2V/d$$

Where  $E_{\max}$  is the maximum electric field induced in one-sided step junction

When  $N_B$  is increased by  $\alpha$  and if  $V_\alpha=0$ , then  $V_\beta$  is increased by  $\ln \alpha$  and  $d$  is decreased by  $\sqrt{\ln \alpha/\alpha}$ .

There  $E$  is increased by inverse of this factor and reaches  $E_{crit}$

### Limits of miniaturization

The minimum size of transistor is determined by both process technology and the physics of the device itself. Transistor size is defined in terms of channel length  $L$ .  $L$  can be decreased as long as there is no punch through i.e. The depletion region around source should not come closer to that around the drain. So  $L$  must be at least  $2d$  from meeting. Depletion region width  $d$  for the junctions is given by

$$D = \sqrt{2E_{si}E_o V/qN_B}$$

Where

$E_{si}$ = relative permittivity of silicon (~12)

$E_o$ = permittivity of free space (=8.85x10<sup>-14</sup>)

$V$ =effective voltage across the junction

$$V = V_a + V_B$$

$q$ =electron charge

$N_B$ =doping level of substrate.

$V_a$ = (maximum value = $V_{DD}$ )=applied voltage

$V_B$ =built-in (junction) potential

$$\text{And } V_B = KT/q \cdot \ln(N_B N_D / n_i^2)$$

Where  $N_D$  is the source or drain doping and  $n_i$  is the intrinsic carrier concentration in silicon.

### Depletion width

When  $N_B$  is increased, the depletion width decreases and  $V_t$  increases which is not desirable.

We have  $V_{\text{drift}} = \mu E$

$V_{\text{drift}}$  is the carrier drift velocity and  $L=2d$

$$\text{Transit time } \tau = L/V_{\text{drift}} = 2d/\mu E$$

### Limits due to interconnect and contact resistance

Since the width, thickness and spacing are scaled by  $1/\alpha$ , cross-section area must be scaled by  $1/\alpha^2$ . Thus  $R$  is increased by  $\alpha$  and  $I$  is scaled by  $1/\alpha$ . so  $IR$  drop remains constant. Thus driving capability and noise margins are degraded.

The propagation delay  $T_p$  along a single aluminum interconnect can be calculated from the following equation

$$T_p = R_{int}C_{int} + 2.3(R_{on}C_{int} + R_{on}C_L + R_{int}C_L)$$

$$T_p \approx (2.3R_{on} + R_{int}) \cdot C_{int}$$

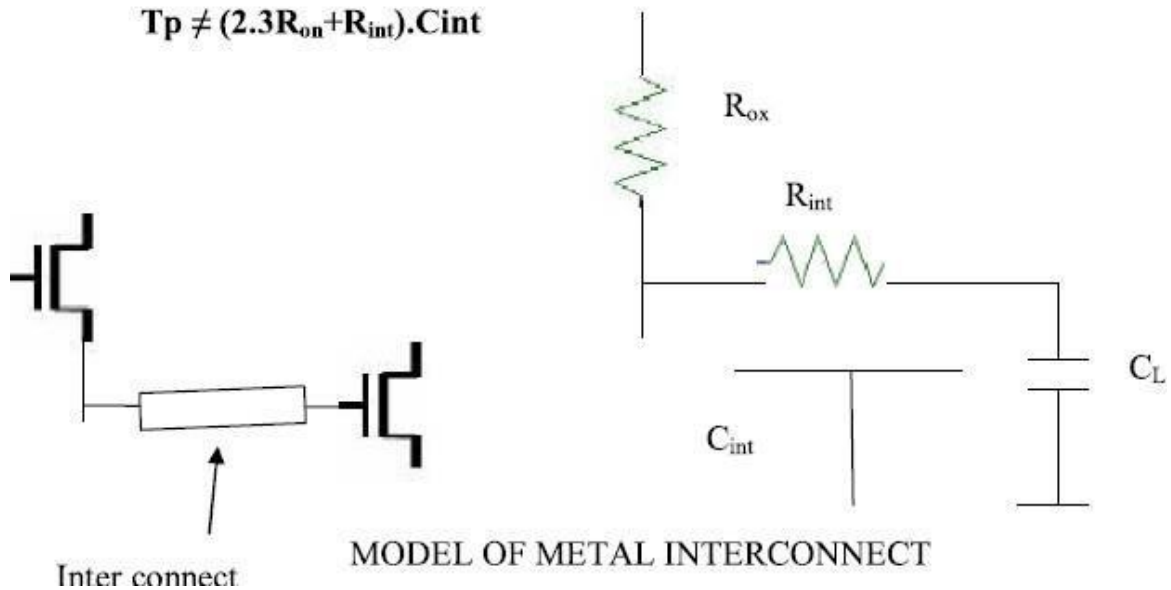

Now

$$R_{int} = \rho L / HW$$

$$C_{int} = \epsilon_{ox} [1.15W/t_{ox} + 2.28(H/t_{ox})^{0.222}] L$$

Where  $R_{on}$  is the ON resistance of the transistor.

$R_{int}$  is the resistance of the interconnect

$C_{int}$  is the capacitance of interconnect

$t_{ox}$  is the thickness of dielectric oxide.

$\rho$  is the resistivity of interconnect L, W, H are the length, width and height of the interconnect.

**Assignment questions:**

1. Draw the circuit diagram; stick diagram and layout for CMOS inverter.
2. Explain about the various layout design rules.
3. Draw the static CMOS logic circuit for the following expression
  1. i)  $Y = (ABCD)'$  ii)  $Y = [D(A+BC)]'$
4. Explain in detail about the scaling concept in VLSI circuit Design.
5. Draw the Layout Diagrams for NAND Gate using nMOS..
6. Explain  $\lambda$ -based Design Rules in VLSI circuit Design.
7. Draw the Layout Diagrams for CMOS Inverter.
8. Discuss about the stick diagrams and their corresponding mask layout examples
9. Draw the stick diagram of p-well CMOS inverter and explain the process.
10. Explain about the 2  $\mu\text{m}$  CMOS Design rules and discuss with a layout example.
11. Draw and explain the layout for CMOS 2-input NAND gate.
12. Draw the flow chart of VLSI Design flow and explain the operation of each step in detail.
13. Draw the stick diagram for three input AND gate.
14. What is the purpose of design rule? What is the purpose of stick diagram? What are the different approaches for describing the design rule? Give three approaches for making contacts between poly silicon and discussion in NMOS circuit.

## UNIT III

# GATE LEVEL DESIGN AND BASIC CIRCUIT CONCEPTS

### **Gate level Design:**

- Logic gates and other complex gates
- Switch logic
- Alternate gate circuits

### **Basic Circuit Concepts:**

- Sheet Resistance  $R_s$  and its concepts to MOS
- Area Capacitances calculations
- Inverter Delays
- Fan-in and fan-out.

## CMOS Logic gates and other complex gates

Name	Logic symbol	Logic equation
INVERTER		$Out = \sim in;$
AND		$Out = a \& b;$
NAND		$Out = \sim(a \cdot b);$
OR		$Out = (a   b);$
NOR		$Out = \sim(a   b);$
XOR		$Out = a \wedge b;$
XNOR		$Out = \sim(a \wedge b);$

## CMOS logic gate concept:

The structure of a CMOS logic gate is based on complementary networks of n-channel and p-channel MOS circuits. Recall that the pMOS switch is good at passing logic signal '1', while nMOS switches are good at passing logic signal '0'. The operation of the gate has two main configurations:

- the nMOS switch network is closed, the output  $s=0$  (figure 6-6 left)
- the pMOS switch network is closed, the output  $s=1$  (figure 6-6 right)

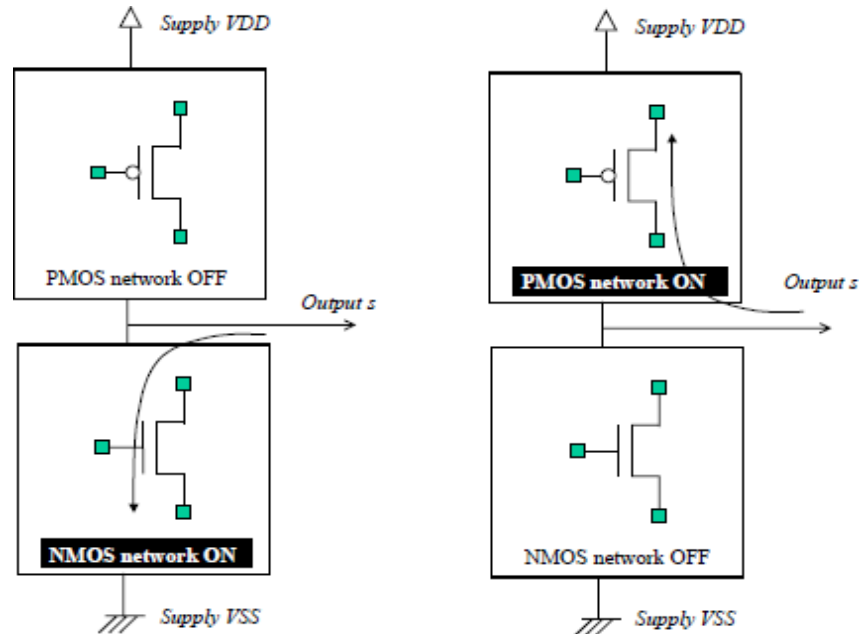

Fig. 6-6. General structure of a CMOS basic gate

Using complementary pairs of nMOS and pMOS devices, either the lower nMOS network is active, which ties the output to ground, either the upper pMOS network is active, which ties the output to VDD. In conventional CMOS basic gates, there should exist no combination when both nMOS and pMOS networks would be ON. If this case had

happened, a resistive path would be created between VDD and VSS supply rails. The situation where neither nMOS and pMOS networks would be OFF should also be avoided, because the output would be undetermined.

## **CMOS Static logic**

Static, fully complementary CMOS gate designs using inverter, NAND and NOR gates can build more complex functions. These CMOS gates have good noise margins and low static power dissipation at the cost of more transistors when compared with other CMOS logic designs. CMOS static complementary gates have two transistor nets (nMOS and pMOS) whose topologies are related. The pMOS transistor net is connected between the power supply and the logic gate output, whereas the nMOS transistor topology is connected between the output and ground (Fig. 5.1). We saw this organisation with the NAND and NOR gates, but we point out this topology to lead to a general technique to convert Boolean algebra statements to CMOS electronic circuits.

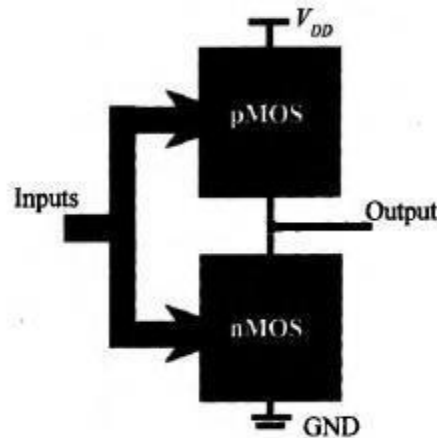

**Fig. 5.1** Standard configuration of a CMOS complementary gate.

## **Design Procedure:**

1. Derive the nMOS transistor topology with the following rules:
  - Product terms in the Boolean function are implemented with series-connected nMOS transistors.
  - Sum terms are mapped to nMOS transistors connected in parallel.
2. The pMOS transistor network has a dual or complementary topology with respect to the nMOS net. This means that serial transistors in the nMOS net convert to parallel transistors in the pMOS net, and parallel connections within the nMOS block are translated to serial connections in the pMOS block.
3. Add an inverter to the output to complete the function if needed. Some functions are inherently negated, such as NAND and NOR gates, and do not need an inverter at the output state. An inverter added to a NAND or NOR function produces the AND and OR function. The examples below require an inverter to fulfil the function.

**Examples:****Example Gate: NOR**

A	B	Out
0	0	1
0	1	0
1	0	0
1	1	0

Truth Table of a 2 input NOR gate

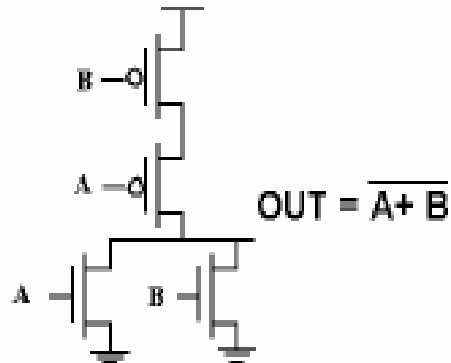
**Example Gate: NAND**

A	B	Out
0	0	1
0	1	1
1	0	1
1	1	0

Truth Table of a 2 input NAND gate

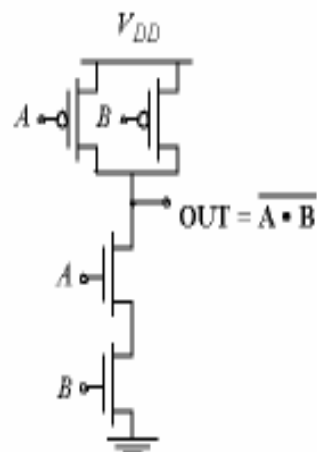

PDN:  $G = A \cdot B \Rightarrow$  Conduction to GND

PUN:  $F = \overline{A + B} = \overline{AB} \Rightarrow$  Conduction to  $V_{DD}$

$$\overline{G(In_1, In_2, In_3, \dots)} = F(\overline{In_1}, \overline{In_2}, \overline{In_3}, \dots)$$

1.

Design a complementary static CMOS XOR gate at the transistor level. The XOR gate Boolean expression  $F$  has four literals and is  $F = \bar{x}y + x\bar{y}$ .

$F$  is the sum of two product terms. The design steps are:

1. Derive the nMOS transistor topology with four transistors, one per literal in the Boolean expression. The transistors driven by  $\bar{x}$  and  $y$  are connected in series, as well as the devices driven by  $x$  and  $\bar{y}$ . These transistor groups are connected in parallel, since they are additive in the Boolean function. The signals and their complements are generated using inverters (not shown). The nMOS transistor net is shown in Fig. 5.2.

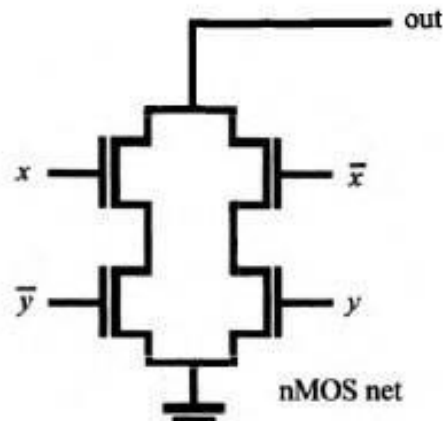

Fig. 5.2

2. Implement the pMOS net as a dual topology to the nMOS net. The pMOS transistors driven by  $\bar{x}$  and  $y$  are connected in parallel, as are the devices driven by  $x$  and  $\bar{y}$  (Fig. 5.3). These transistor groups are connected in series, since they are parallel connected in the nMOS net. The *out* node now implements  $\bar{F}$ .

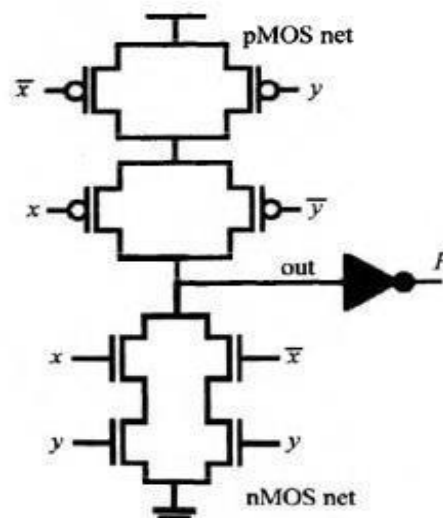

Fig. 5.3

3. Finally, add an inverter to obtain the function  $F$ , so that  $F = \overline{\text{out}}$ .
2. Design the nMOS transistor net for a Boolean function  $F = x + \{\bar{y} \cdot [z + (t \cdot \bar{w})]\}$ . We design this gate with a top-down approach. The nMOS transistor network is connected between the output and ground terminals, i.e., the lower box in Fig. 5.4(b). The higher-level function  $F$  is a sum of two terms:
- $F = x + \{\text{operation A}\}$  where operation A stands for the logic within the brackets of  $F$ . The transistor version of this sum is shown in Fig. 5.4(a).

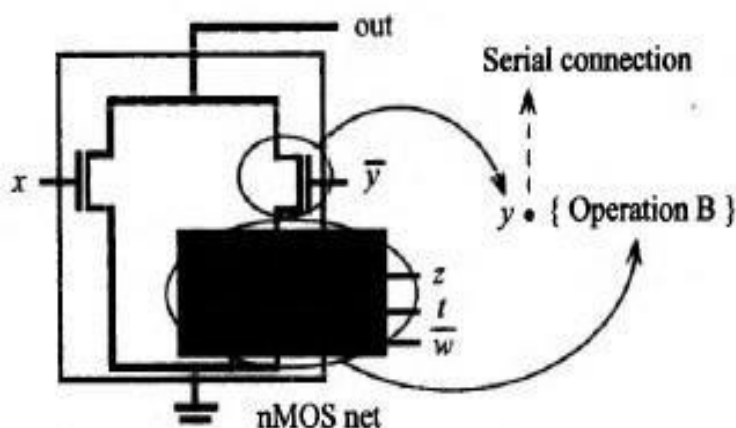

Fig. 5.4(a)

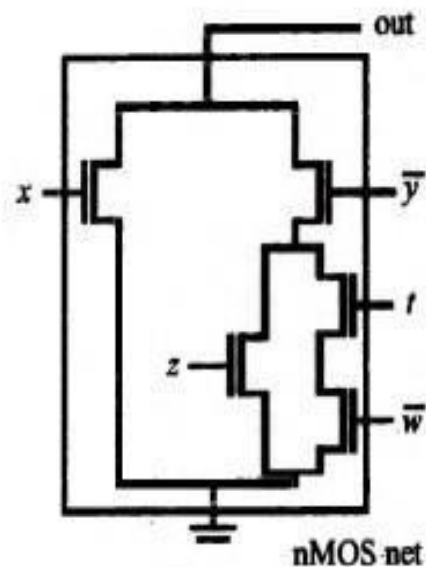

Fig. 5.4(b)

Hence, the design topology is a transistor controlled by input  $\bar{y}$  in series with a third box that will implement *operation B*, as shown in Fig. 5.4. We then design the topology of box B. This is a transistor controlled by input  $z$ , in parallel with two transistors connected in series; one controlled by input  $t$ , and the other by input  $\bar{w}$ . The complete nMOS network is shown in Fig. 5.4(b). Once the nMOS block is designed, we build the pMOS block with a dual topological structure and then connect an inverter to its output, as shown in Fig. 5.6.

**Complex Gates:****Complex Gate**

- ◆ We can form complex combinational circuit function in a complementary tree. The procedure to construct a complementary tree is as follow:-

- Express the boolean expression in an inverted form
- For the n-transistor tree, working from the inner-most bracket to the outer-most term, connect the **OR** term transistors in parallel, and the **AND** term transistors in series
- For the p-transistor tree, working from the inner-most bracket to the outer-most term, connect the **OR** term transistors in series, and the **AND** term transistors in parallel

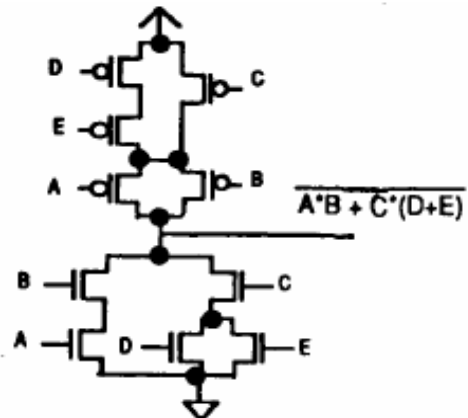
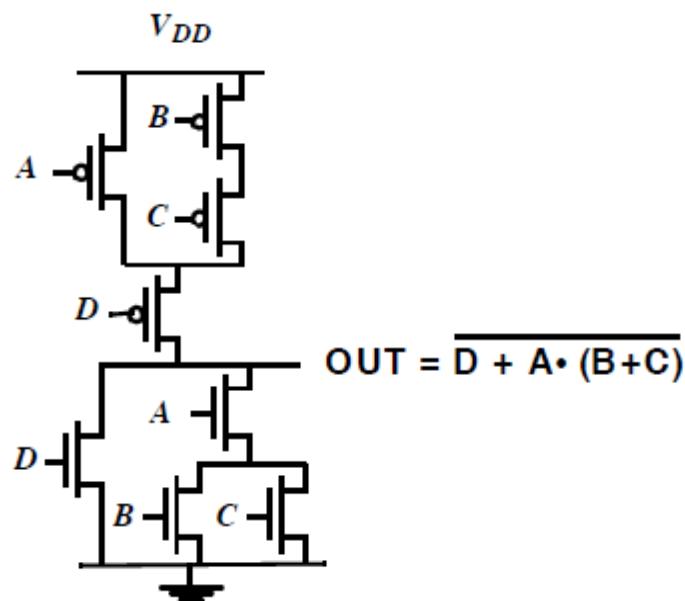
**Example Gate: COMPLEX CMOS GATE****Transmission gate logic:**

A **transmission gate** is an electronic element. It is a good non-mechanical relay, built with CMOS technology. Sometimes known as an analog gate, analog switch or electronic relay depending on its use. It is made by the parallel combination of an nMOS and a pMOS transistor with the input at the gate of one transistor being complementary to the input at the gate of the other.

A *transmission gate* is essentially a switch that connects two points. In order to pass 0's and 1's equally well, a pair of transistors (one N-Channel and one P-Channel) is used as shown below:

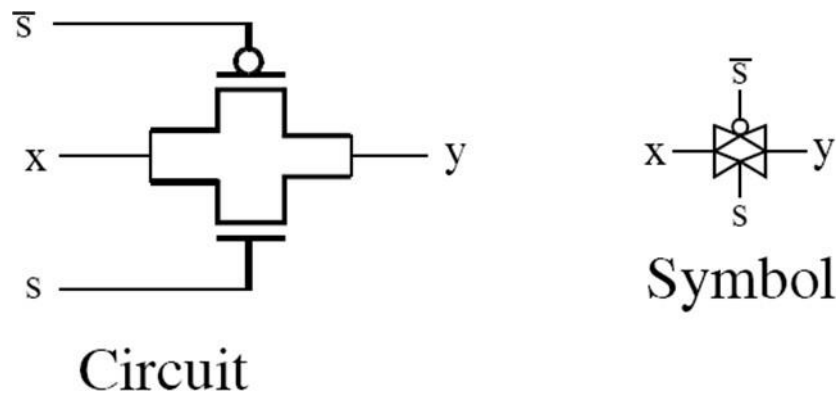

When  $s = 1$  the two transistors conduct and connect  $x$  and  $y$

The top transistor passes  $x$  when it is 1 and the bottom transistor passes  $x$  when it is 0

When  $s = 0$  the two transistors are cut off disconnecting  $x$  and  $y$

N-Channel MOS Transistors pass a 0 better than a 1

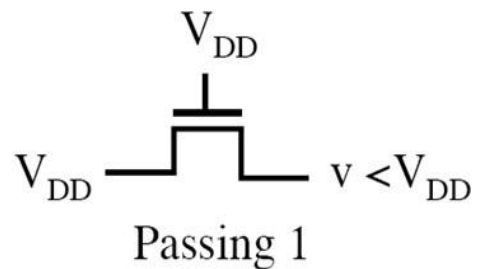
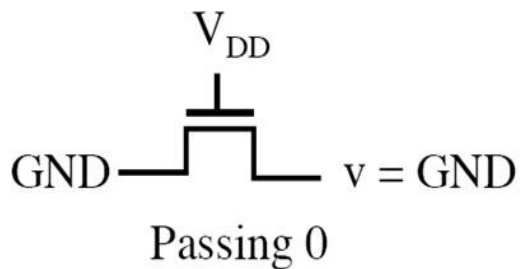

P-Channel MOS Transistors pass a 1 better than a 0

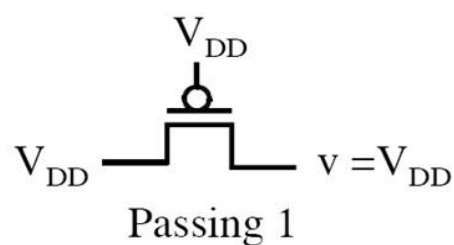
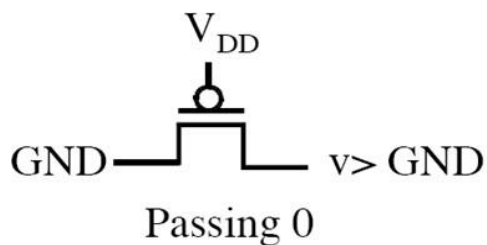

This is the reason that N-Channel transistors are used in the pull-down network and P-Channel in the pull-up network of a CMOS gate. Otherwise the noise margin would be significantly reduced.

### **Tristate gates:**

Many logic gates require a tri-state output—high, low, and high-impedance states. The high-impedance state is also called the high-Z state, and is useful when connecting many gate outputs to a single line, such as a data bus or address line. A potential conflict would exist if more than one gate output tried to simultaneously control the bus line. A controllable high-impedance-state circuit solves this problem.

There are two ways to provide high impedance to CMOS gates. One way provides tristate output to a CMOS gate by connecting a transmission gate at its output (Fig. 5.7). The control signal  $C$  sets the transmission gate conducting state that passes the non-tristated inverter output  $\overline{\text{out}}$  to the tri-stated gate output  $\text{out}$ . When the transmission gate is off ( $C = 0$ ), then its gate output is in the high-impedance or floating state. When  $C = 1$ , the transmission gate is on and the output is driven by the inverter.

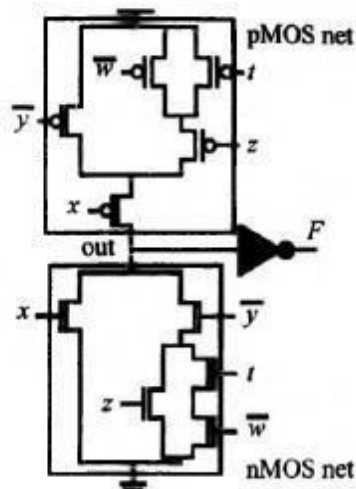

Fig. 5.6

A transmission gate connected to the output provides tri-state capability, but also consumes unnecessary power. The design of Fig. 5.7 contributes to dynamic power each time that the input and output ( $\overline{\text{out}}$ ) are switched, even when the gate is disabled in the tri-state mode. Parasitic capacitors are charged and discharged. Since the logic activity at the input does not contribute to the logic result while the output is in tri-state, the power consumption related to this switching is wasted.

## Pass Transistor Logic

Pass Transistor Logic (PTL) describes several logic families used in the design of integrated circuits. It reduces the count of transistors used to make different logic gates, by eliminating redundant transistors.

Advantages are the low number of transistors and the reduction in associated interconnects. The drawbacks are the limited driving capability of these gates and the decreasing signal strength when cascading gates. These gates do not restore levels since their outputs are driven from the inputs, and not from  $V_{DD}$  or ground.

A typical CMOS design is the gate-level multiplexer (MUX) shown in Fig. 5.9 for a 2-to-1 MUX

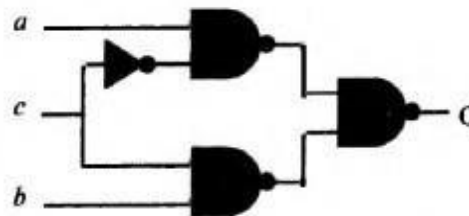
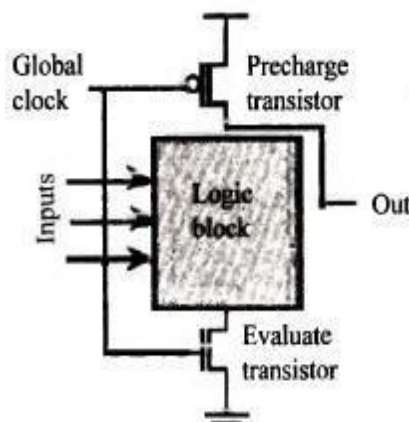

Fig. 5.9 (a) Standard 2-to-1 MUX design. (

## Dynamic CMOS logic:



Basic Structure of a dynamic CMOS gate

This logic looks into enhancing the speed of the pull up device by precharging the output node to  $V_{dd}$ . Hence we need to split the working of the device into precharge and evaluate stage for which we need a clock. Hence it is called as dynamic logic. The output node is precharged to  $V_{dd}$  by the pmos and is discharged conditionally through the nmos. Alternatively you can also have a p block and precharge the n transistor to  $V_{ss}$ . When the clock is low the precharge phase occurs. The path to  $V_{ss}$  is closed by the nmos i.e. the ground switch. The pull up time is

improved because of the active pmos which is already precharged. But the pull down time increases because of the ground switch.

There are a few problems associated with the design, like

- Inputs have to change during the precharge stage and must be stable during the evaluate. If this condition cannot occur then charge redistribution corrupts the output node.
- A simple single dynamic logic cannot be cascaded. During the evaluate phase the first gate will conditionally discharge but by the time the second gate evaluates, there is going to be a finite delay. By then the first gate may precharge.

### **Merits and Demerits:**

1. They use fewer transistors and, therefore, less area.
2. Fewer transistors result in smaller input capacitance, presenting a smaller load to previous gates, and therefore faster switching speed.
3. Gates are designed and transistors sized for fast switching characteristics. High performance circuits use these families.

The logic transition voltages are smaller than in static circuits, requiring less time to switch between logic levels.

The disadvantages of dynamic CMOS circuits are

1. Each gate needs a clock signal that must be routed through the whole circuit. This requires precise timing control.
2. Clock circuitry runs continuously, drawing significant power.
3. The circuit loses its state if the clock stops.
4. Dynamic circuits are more sensitive to noise.
5. Clock and data must be carefully synchronized to avoid erroneous states.

### **Domino CMOS Logic**

This logic is the most common form of dynamic gates, achieving a 20%-50% performance increase over static logic. When the nMOS logic block discharges the out node during evaluation (Fig. 5.12), the inverter output out goes high, turning off the feedback pMOS. When out is evaluated high (high impedance in the dynamic gate), then the inverter output goes low, turning on the feedback pMOS device and providing a low impedance path to  $V_{DD}$ , This prevents the out node from floating, making it less sensitive to node voltage drift, noise and current leakage.

Domino CMOS allows logic gate cascading since all inputs are set to zero during precharge, avoiding erroneous evaluation from different delays. This logic allows static operation from the feedback latching pMOS, but logic evaluation still needs two sub cycles: precharge and evaluation.

Domino logic uses only non-inverting gates, making it an incomplete log family. To achieve inverted logic, a separate inverting path running in parallel with the non inverted one must be designed.

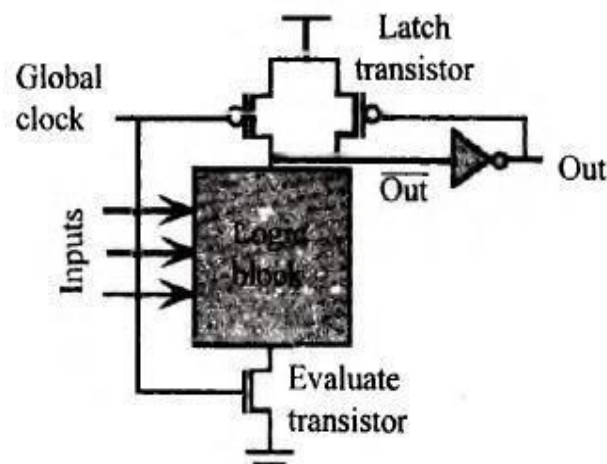

**Fig. 5.12** Domino CMOS logic gate with feedback transistor.

Multiple output domino logic (MODL) is an extension of domino logic, taking internal nodes of the logic block as signal outputs, thus saving area, power, and performance. Compound domino logic is another design that limits the length of the evaluation logic to prevent charge sharing, and adds other complex gates as buffer elements (NAND, NOR, etc. instead of inverters) to obtain more area compaction. Self-resetting domino logic (SRCMOS) has each gate detect its own operating clock, thus reducing clock overhead and providing high performance.

**NORA CMOS Logic.** This design alternative to domino CMOS logic eliminates the output buffer without causing race problems between clock and data that arise when cascading dynamic gates. NORA CMOS (No-Race CMOS) avoids these race problems by cascading alternate nMOS and pMOS blocks for logic evaluation. The cost is routing two complemented clock signals. The cascaded NORA gate structure is shown in Fig. 5.13. When the global clock ( $GC$ ) is low ( $\overline{GC}$  high), the nMOS logic block output nodes are precharged high, while outputs of gates with pMOS logic blocks are precharged low. When the clock changes, gates are in the evaluate state.

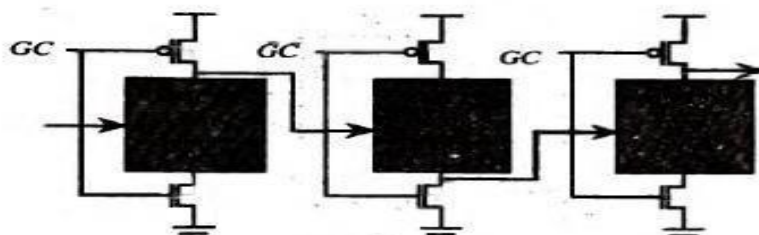

**Fig. 5.13** NORA CMOS cascaded gates.

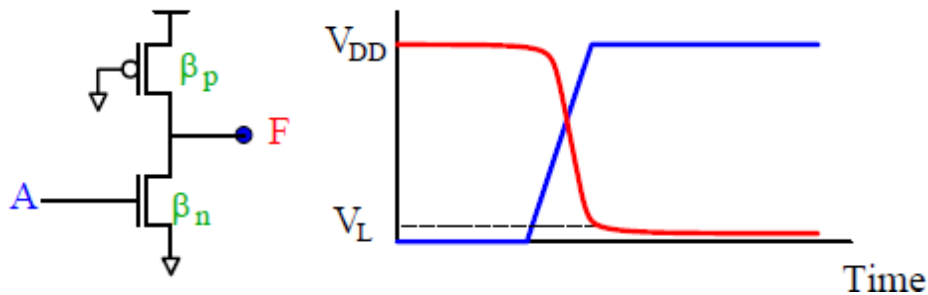
**Pseudo – NMOS Logic:****pseudo-NMOS inverter**

The inverter that uses a p-device pull-up or loads that has its gate permanently ground. An n-device pull-down or driver is driven with the input signal. This roughly equivalent to use of a depletion load is NMOS technology and is thus called '**Pseudo-NMOS**'. The circuit is used in a variety of CMOS **logic** circuits.

The low output voltage can be calculated as

$$\beta_n (V_{DD} - V_{tn}) V_L = \frac{\beta_p}{2} (V_{DD} - |V_{tp}|)^2$$

$$\text{for } V_{tn} = -V_{tp} = V_t$$

$$V_L = \frac{\beta_p}{2\beta_n} (V_{DD} - V_T)$$

Thus  $V_L$  depends strongly on the ratio  $\beta_p / \beta_n$   
The logic is also called **ratioed logic**

An N-input pseudo-NMOS gate

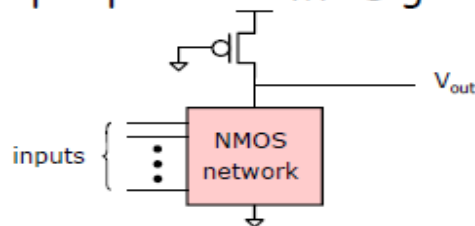

**Features of pseudo-NMOS logic**

- **Advantages**
  - Low area cost → only N+1 transistors are needed for an N-input gate
  - Low input gate-load capacitance →  $C_{gn}$
- **Disadvantage**
  - Non-zero static power dissipation

## **Basic Circuit Concepts:**

### **Sheet Resistance $R_s$ and its concepts to MOS**

The sheet resistance is a measure of resistance of thin films that have a uniform thickness. It is commonly used to characterize materials made by semiconductor doping, metal deposition, resistive paste printing, and glass coating.

Example of these processes are: doped semiconductor regions (eg: silicon or polysilicon) and resistors.

**Sheet resistance is applicable to two-dimensional systems where the thin film is considered to be a two-dimensional entity. It is analogous to resistivity as used in three-dimensional systems. When the term sheet resistance is used, the current must be flowing along the plane of the sheet, not perpendicular to it.**

#### **Model:**

Consider a uniform slab of conducting material of resistivity  $\rho$ , of width  $W$ , thickness  $t$ , and length between faces  $L$  as shown below:

$$R_{AB} = \frac{\rho L}{tW} \quad \text{ohm}$$

Where  $A$  = cross section area.

$$\text{Thus } R_{AB} = \frac{\rho L}{tW} \quad \text{ohm.}$$

When  $L = W$ , i.e. a square resistive material, then

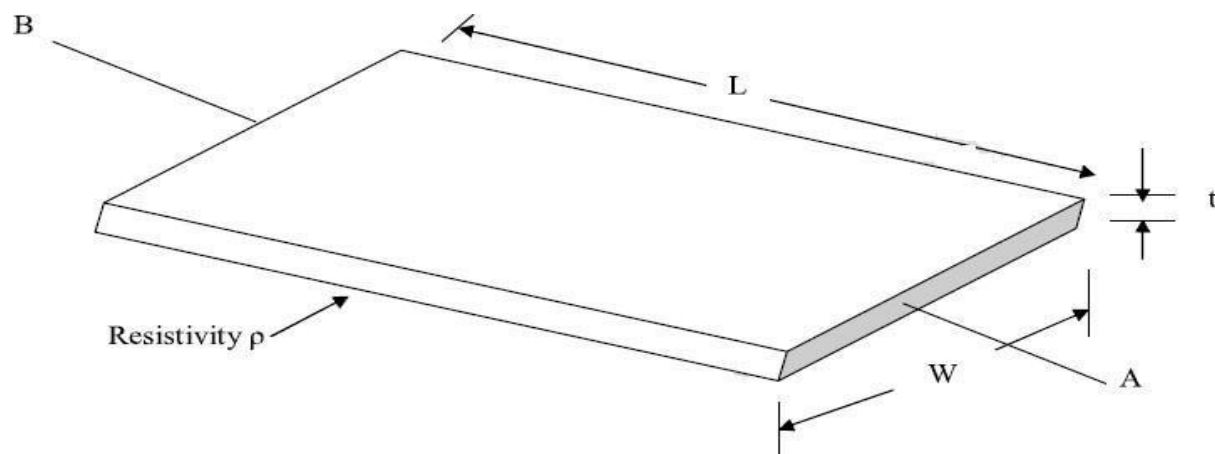

$$R_{AB} = \frac{\rho}{t} = R_s$$

Where  $R_s$  = ohm per square or sheet resistance.

$$\text{Thus } R_s = \frac{\rho}{t} \text{ ohm per square.}$$

It is completely independent of the area of the square.

### Typical sheet resistance $R_s$ of MOS layers

Layer	$R_s$ ohm per square		
	5 $\mu$ m	Orbit	1.2 $\mu$ m
Metal	0.03	0.04	0.04
Diffusion	10 $\rightarrow$ 50	20 $\rightarrow$ 45	20 $\rightarrow$ 45
Silicide	2 $\rightarrow$ 4	-	-
Polysilicon	15 $\rightarrow$ 100	15 $\rightarrow$ 30	15 $\rightarrow$ 30
n-transistor channel	$10^4$	$2 \times 10^4$	$2 \times 10^4$
p-transistor channel	$2.5 \times 10^4$	$4.5 \times 10^4$	$4.5 \times 10^4$

### SHEET RESISTANCE CONCEPT APPLIED TO MOS TRANSISTORS AND INVERTERS

The simple n-type pass transistor has a channel length  $L = 2\lambda$  and a channel width  $W = 2\lambda$ . The channel is square

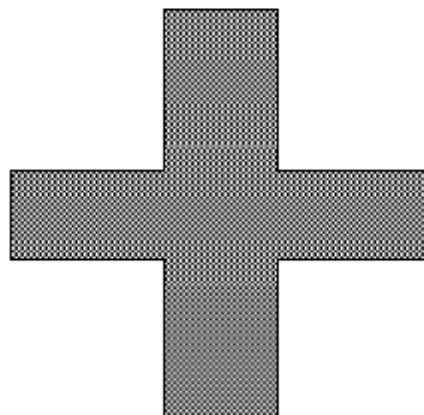

$$R = \text{square} \times R_s \frac{\text{Ohm}}{\text{square}} = R_s = 10^4 \text{ ohm.}$$

The length to width ratio, denoted by  $Z$  is 1:1 in this case. Consider one more structure as in diagram below.

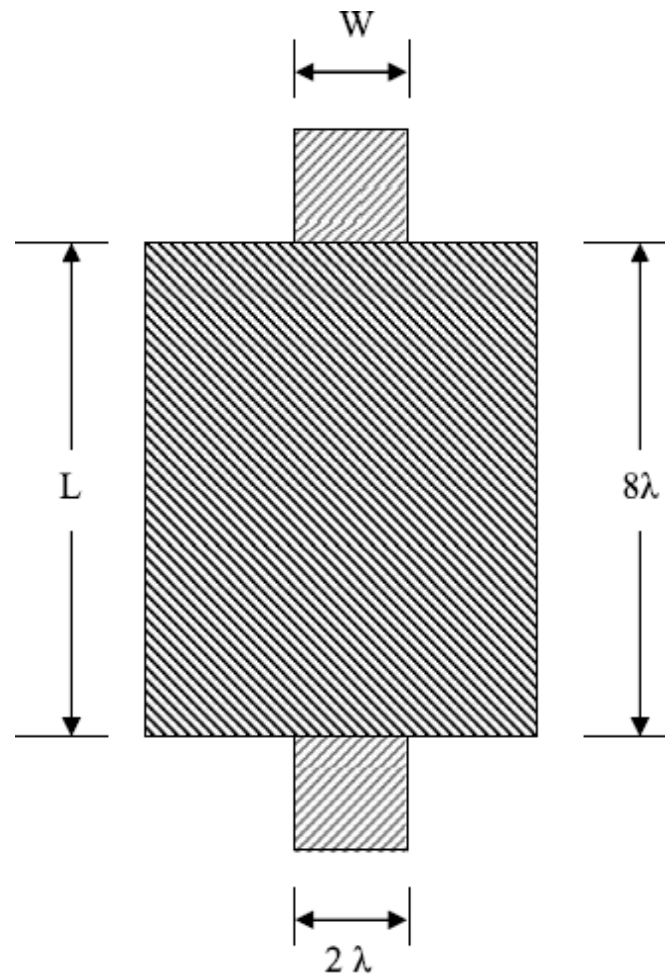

$$L = 8\lambda \text{ and } W = 2\lambda$$

$$Z = \frac{L}{W} = 4$$

$$\text{Channel resistance } R = Z R_s = 4 \times 10^4 \text{ Ohm.}$$

This channel can be taken as four  $2\lambda \times 2\lambda$  squares in series.

### Calculation of ON Resistance of a Simple Inverter

Consider the simple nMOS inverter in Fig.

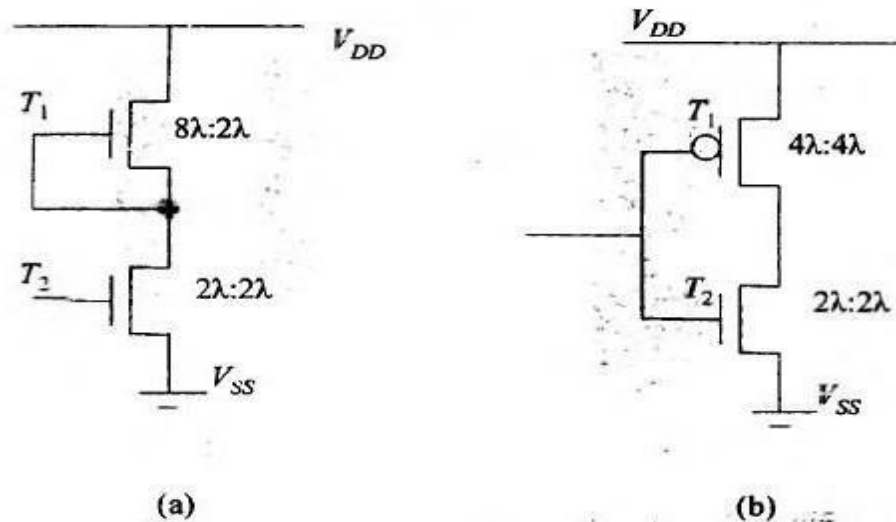

Fig. (a) NMOS Inverter (b) CMOS Inverter resistance calculations

- For the pull-up transistor (depletion mode MOSFET) the  $L:W$  value is 4:1, hence the value of  $Z$  is 4.  $R_{on} = 4$  and value of on resistance is  $4R_s$ , i.e.,  $4 \times 10^4 = 40 \text{ k}\Omega$ .
- Similarly, for the pull down transistor (enhancement mode MOSFET) the  $L:W$  value is 1:1 hence the value of  $Z$  is 1.  $R_{on} = 1$  and value of resistance is  $1R_s$ , i.e.,  $1 \times 10^4 = 10 \text{ k}\Omega$ .
- $Z_{p,u}$  to  $Z_{p,d} = 4:1$  hence the ON resistance between  $V_{DD}$  and  $V_{SS}$  is the total series resistance, i.e.,  $40 \text{ k}\Omega + 10 \text{ k}\Omega = 50 \text{ k}\Omega$ .

Consider the simple CMOS inverter in Fig.

- For the pull-up transistor (p-enhancement mode MOSFET) the  $L:W$  value is 1:1, hence, the value of  $Z$  is 4.  $R_{on} = 4$  and value of on resistance is  $4 R_s$ , i.e.,  $1 \times 25 \times 10^4 = 25 \text{ k}\Omega$  (from the table value of  $R_s$  for p-channel transistor is  $2.5 \times 10^4 \text{ ohm/square}$ ).
- Similarly, for the pull down transistor (n-enhancement mode MOSFET) the  $L:W$  value is 1:1 hence the value of  $Z$  is 1.  $R_{on} = 1$  and value of resistance is  $1 R_s$ , i.e.,  $1 \times 10^4 = 10 \text{ k}\Omega$ .
- In this case, there is no static resistance between  $V_{DD}$  and  $V_{SS}$  since at any point of time only one transistor is ON, but not both.
- When  $V_{in} = 1$ , the ON Resistance is  $10 \text{ k}\Omega$ , when  $V_{in} = 0$  the ON Resistance is  $25 \text{ k}\Omega$ .

### Area Capacitances calculations

From the concept of the transistors, we studied, it is apparent that as gate is separated from the channel by gate oxide an insulating layer, it has capacitance. Similarly, different interconnects run on the chip and each layer is separated by silicon dioxide.

Area capacitance can be calculated as  $C = \frac{\epsilon_o \epsilon_{ins} A}{D}$  farads

Where

D = Thickness of silicon dioxide

A = Area of plates

$\epsilon_{ins}$  = Relative permittivity of SiO<sub>2</sub> = 4.0

$\epsilon_o$  = 8.85 X 10<sup>-14</sup> F/cm (permittivity of free space)

The layer area capacitance is in pF/ $\mu$ m<sup>2</sup> (where  $\mu$ m = micron = 10<sup>-6</sup> meter)  
**Typical values of area capacitance are given below in Fig. :**

Capacitance	Value in pF $\times 10^{-4}/\mu\text{m}^2$ (Relative values in brackets).					
	5 $\mu$ m		2 $\mu$ m		1.2 $\mu$ m	
Gate to channel	4	(1.0)	8	(1.0)	16	(1.0)
Diffusion (active)	1	(0.25)	1.75	(0.22)	3.75	(0.23)
Polysilicon* to substrate	0.4	(0.1)	0.6	(0.075)	0.6	(0.038)
Metal 1 to substrate	0.3	(0.075)	0.33	(0.04)	0.33	(0.02)
Metal 2 to substrate	0.2	(0.05)	0.17	(0.02)	0.17	(0.01)
Metal 2 to metal 1	0.4	(0.1)	0.5	(0.06)	0.5	(0.03)
Metal 2 to polysilicon	0.3	(0.075)	0.3	(0.038)	0.3	(0.018)

### Standard unit of capacitance:

A standard unit is employed that can be used in calculations. The unit is denoted as C<sub>g</sub> and is defined as the gate-to-channel capacitance of a MOS transistor having W = L = feature size, that is a 'standard' or 'feature size' square.

C<sub>g</sub> may be evaluated for any MOS process.

For example, for 5 $\mu$ m MOS circuits

Area/standard square = 5 $\mu$ m X 5 $\mu$ m = 25 $\mu$ m<sup>2</sup>

$$\begin{aligned} \text{Capacitance value} &= 4 \times 10^{-4} \text{ pF}/\mu\text{m}^2 \\ \text{Thus standard value of } C_g &= 25 \mu\text{m}^2 \times 4 \times 10^{-4} \text{ pF}/\mu\text{m}^2 \\ &= 0.01 \text{ pF} \end{aligned}$$

For 2  $\mu\text{m}$  MOS circuits  $C_g = 0.0032 \text{ pF}$  and for 1.2  $\mu\text{m}$  MOS circuits  $C_g = 0.0023 \text{ pF}$

### Calculation of Delay unit $\tau$

The delay unit  $\Gamma$  is the product of  $1 R_s$  and  $1 C_g$

$$\Gamma = (1 R_s (\text{n-channel}) \times 1 C_g) \text{ seconds}$$

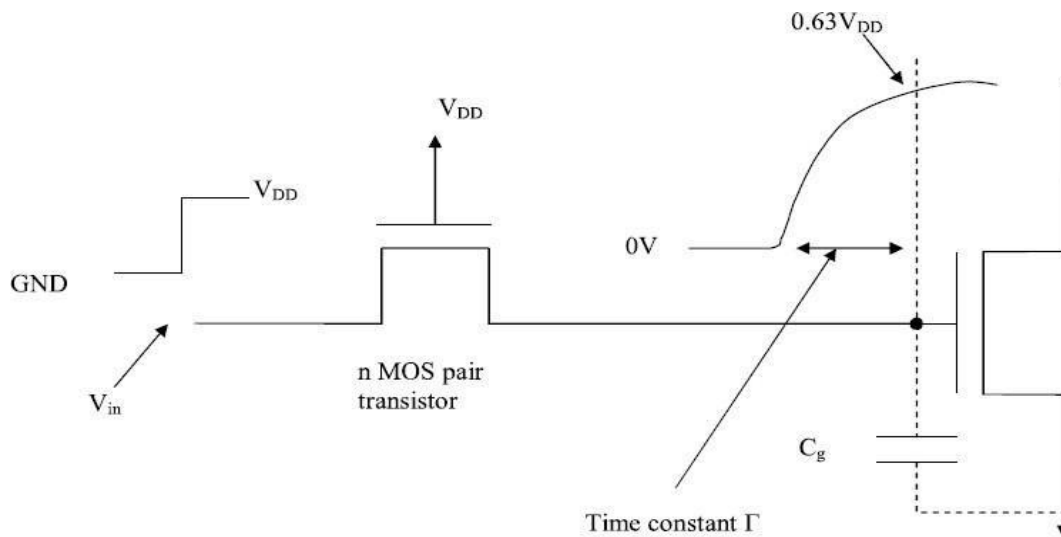

For 5 $\mu\text{m}$  technology

$$\begin{aligned} \Gamma &= 10^4 \text{ ohm} \times 0.01 \text{ pF} \\ &= 0.1 \text{ n sec} \end{aligned}$$

For 2 $\mu\text{m}$  technology

$$\begin{aligned} \Gamma &= 2 \times 10^4 \text{ ohm} \times 0.0032 \text{ pF} \\ &= 0.064 \text{ n sec} \end{aligned}$$

For 1.2 $\mu\text{m}$  (orbit) technology

$$\begin{aligned} \Gamma &= 2 \times 10^4 \text{ ohm} \times 0.0023 \text{ pF} \\ &= 0.046 \text{ n sec} \end{aligned}$$

Practically  $\Gamma = 0.2$  to  $0.3 \text{ n sec}$  for a 5 $\mu\text{m}$  technology because of circuit wiring and parasitic capacitances taken into account.

$$\begin{aligned} \tau \approx \tau_{sd} &= \frac{L^2}{\mu_n V_{ds}} = \frac{25 \mu\text{m}^2 V \text{ sec}}{650 \text{ cm}^2 \cdot 3V} \times \frac{10^9 \text{ n sec cm}^2}{10^8 \mu\text{m}^2} \\ &= 0.13 \text{ n sec} \end{aligned}$$

$V_{ds}$  varies as  $C_g$  charges from 0 volts to 63% of  $V_{DD}$  in period  $\Gamma$ . Transit time and time constant  $\Gamma$  can be used interchangeably.

**Inverter Delays:*****nMOS Inverter Pair Delay***

Consider 4 : 1 ratio nMOS inverter. To get 4 : 1  $Z_{pu}$  to  $Z_{pd}$  ratio,  $R_{pu}$  will be 4  $R_{pd}$

$$R_{pu} = 4 R_s = 40k\Omega$$

$$\text{Meanwhile } R_{pd} = 1R_s = 10k\Omega$$

Consider a pair of cascaded inverters, the delay over the pair is constant. This is observed in diagram below:

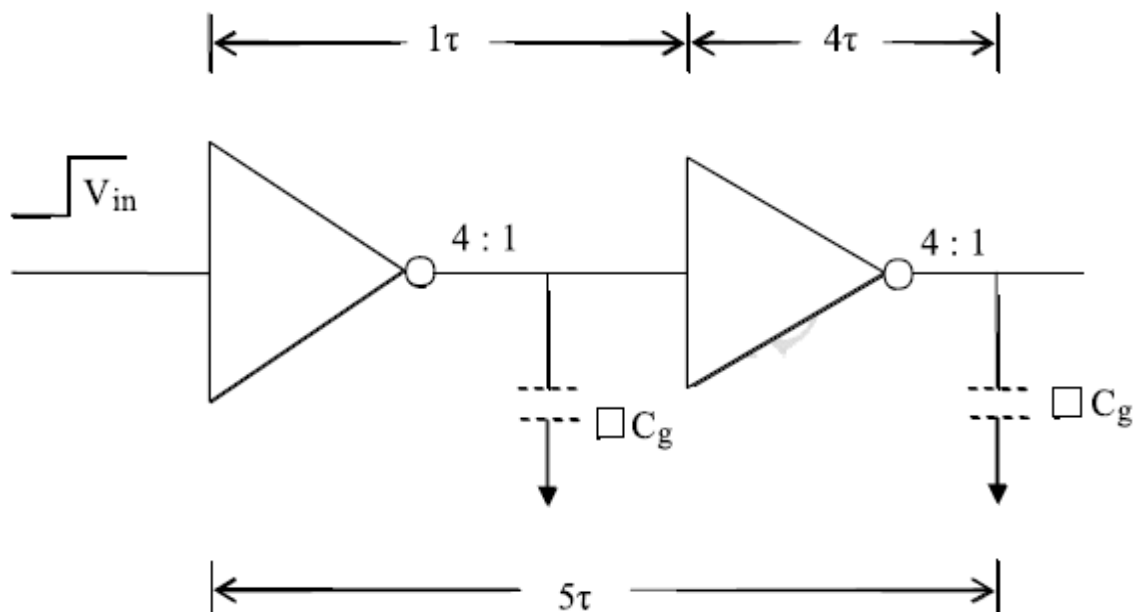

Assuming  $\tau = 0.3$  nsec, over all delay =  $\tau + 4\tau = 5\tau$ .

The general equation is  $\tau_d = \left(1 + \frac{Z_{p,u}}{Z_{p,d}}\right)\tau$

Consider CMOS inverter, the nmos rule does not apply. The gate capacitance is

$2 C_g$  Because the input is connected to both transistor gates.

### Minimum Size CMOS Inverter Pair Delay

When considering CMOS inverters, the nMOS ratio rule no longer applies, but we must allow for the natural ( $R_s$ ) asymmetry of the usually equal size pull-up p-transistors and the n-type pull-down transistors. Figure 5.21 shows the theoretical delay associated with a pair of minimum size (both n- and p-transistors) lambda-based inverters. Note that the gate capacitance ( $=2\Box C_g$ ) is double that of the comparable nMOS inverter since the input to a CMOS inverter is connected to both transistor gates. Note also the allowance made for the differing channel resistances.

The asymmetry of resistance values can be eliminated by increasing the width of the p-device channel by a factor of two or three, but it should be noted that the gate input capacitance of the p-transistor is also increased by the same factor. This, to some extent, offsets the speed-up due to the drop in resistance, but there is a small net gain since the wiring capacitance will be the same.

GATE LEVEL DESIGN 

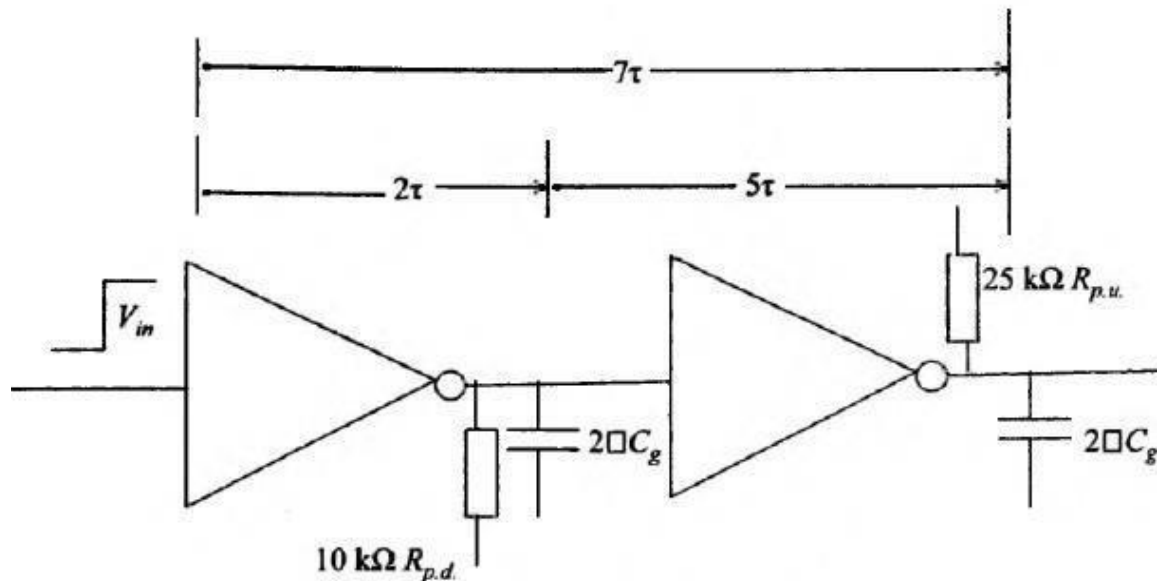

**Fig. 5.21** Minimum size CMOS inverter pair delay.

**Fan in and Fan out:**

- Fan-In = Number of inputs to a logic gate
  - 4 input NAND has a FI = 4
  - 2 input NOR has a FI = 2, etc. (See Fig. a below.)
- Fan-Out (FO)= Number of gate inputs which are driven by a particular gate output
  - FO = 4 in Fig. b below shows an output wire feeding an input on four different logic gates
- The circuit delay of a gate is a function of both the Fan-In and the Fan-Out.

Ex. m-input NAND:  $t_{dr} = (R_p/n)(mnC_d + C_r + kC_g)$

$$= t_{\text{internal-r}} + k t_{\text{output-r}}$$

where n = width multiplier, m = fan-in, k = fan-out,  $R_p$  = resistance of min inverter P Tx,  $C_g$  = gate capacitance,  $C_d$  = source/drain capacitance,  $C_r$  = routing (wiring) capacitance.

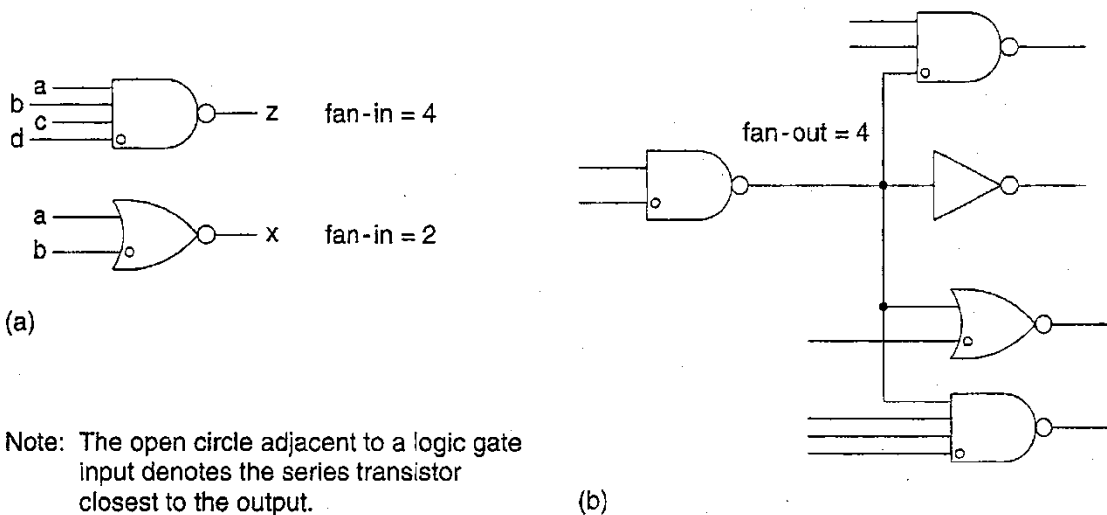

•The circuit fall delay can be written in a similar manner.

$$\begin{aligned} \text{Ex. } m\text{-input NAND: } t_{df} &= m(R_n/n)(mnC_d + C_r + kC_g) \\ &= t_{\text{internal-f}} + k t_{\text{output-f}} \end{aligned}$$

where  $n$  = width multiplier,  $m$  = fan-in,  $k$  = fan-out,  $R_n$  = resistance of min inverter NMOS Tx,  $C_g$  = gate capacitance,  $C_d$  = source/drain capac,  $C_r$  = routing (wiring) capac.

If we set  $t_{dr} = t_{df}$  for the case of symmetrical rise and fall delay, we obtain that  $R_p = m R_n$  and therefore,

$$\beta_p W_p = (\beta_n W_n)/m$$

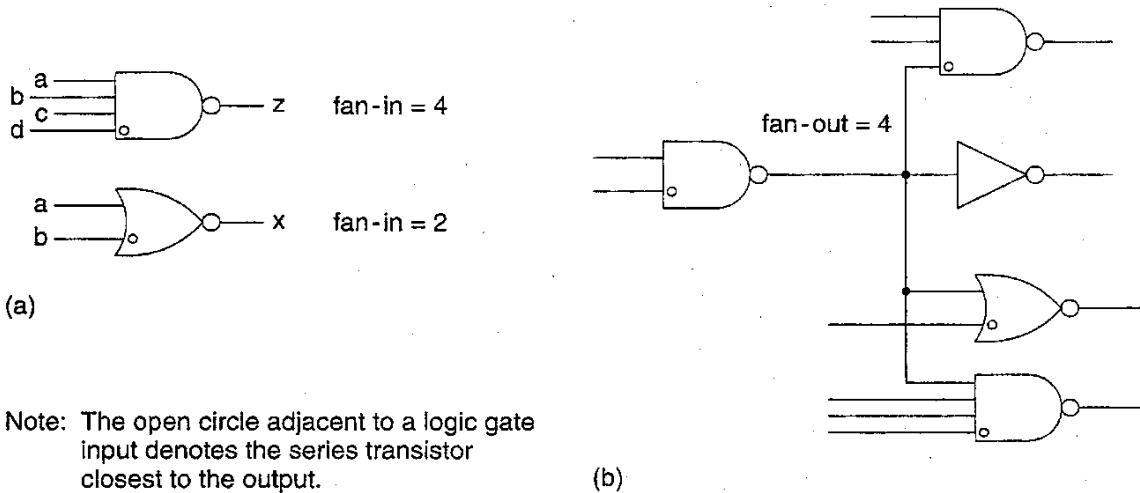

## Summary

1. The **sheet resistance** is a measure of resistance of thin films that have a uniform thickness. It is commonly used to characterize materials made by semiconductor doping, metal deposition, resistive paste printing, and glass coating.
2. The resistance of the MOS layers depends on the thickness and the material of the layer. The resistance value of any square pattern is same as  $W = L$ .
3. Standard unit of capacitance is defined as gate to channel capacitance of a MOS transistor having  $W = L =$  feature size that is standard.
4. Time constant  $\tau = (1R_s (n \text{ channel}) \times 1 \square C_g)$  seconds.

**Assignment Questions:**

1. Describe the following:
  - a) Pseudo-nMOS Logic
  - b) Domino Logic.
2. Discuss about the logics implemented in gate level design and explain the switch logic implementation for a four way multiplexer.
3. Describe about the methods for driving large capacitive loads.
4. Describe about the choice of fan – in and fan – out selection in gate level design.
5. What are the alternate gate circuits available? Explain anyone of item with suitable sketch by taking NAND gate as an example.
6. Explain the Transmission gate and Tristate inverter logic.
7. Describe the nMOS and CMOS inverter pair delays.

## UNIT 4

### Subsystem Design:

Datapath operators benefit from the structured design principles of hierarchy, regularity, modularity, and locality. They may use  $N$  identical circuits to process  $N$ -bit data. Related data operators are placed physically adjacent to each other to reduce wire length and delay. Generally, data is arranged to flow in one direction, while control signals are introduced in a direction orthogonal to the dataflow. Common data path operators include adders, one/zero detectors, comparators, counters, Boolean logic units, error-correcting code blocks, shifters, and multipliers.

**Adder:** Addition forms the basis for many processing operations, from ALUs to address generation to multiplication to filtering. As a result, adder circuits that add two binary numbers are of great interest to digital system designers. Half adders and full adders for single-bit addition. The half adder adds two single-bit inputs,  $A$  and  $B$ . The result is 0, 1, or 2, so two bits are required to represent the value; they are called the sum  $S$  and carry-out  $C_{out}$ .

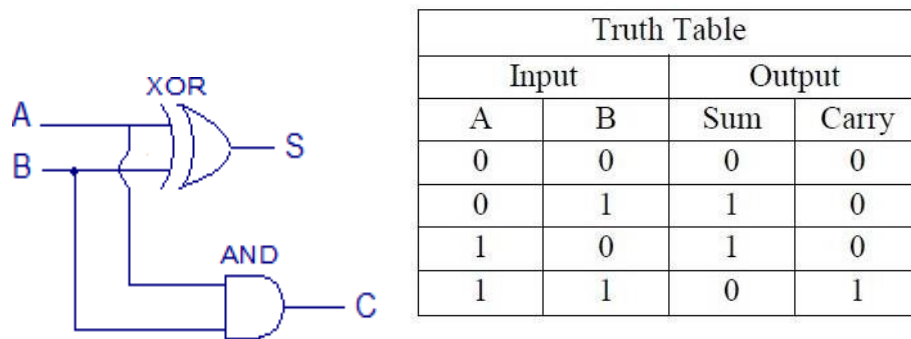

The carry-out is equivalent to a carry-in to the next more significant column of a multibit adder, so it can be described as having double the weight of the other bits. If multiple adders are to be cascaded, each must be able to receive the carry-in. Such a full adder has a third input called  $C$  or  $C_{in}$ .

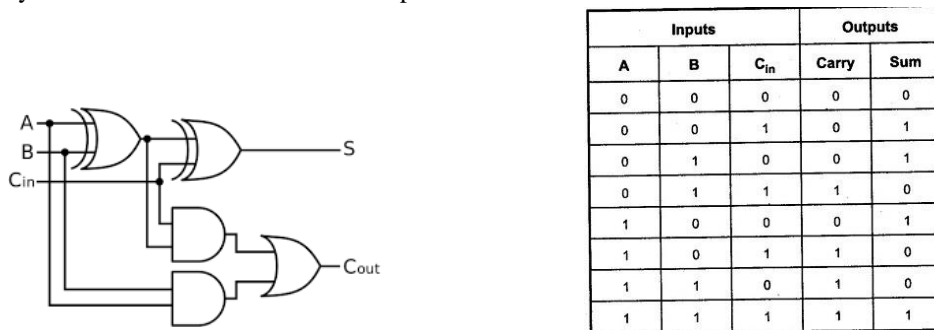

$N$ -bit adders take inputs  $\{A_N, \dots, A_1\}$ ,  $\{B_N, \dots, B_1\}$ , and carry-in  $C_{in}$ , and compute the sum  $\{S_N, \dots, S_1\}$  and the carry-out of the most significant bit  $C_{out}$ . They are called carry-propagate adders (CPAs) because the carry into each bit can influence the carry into all subsequent bits.

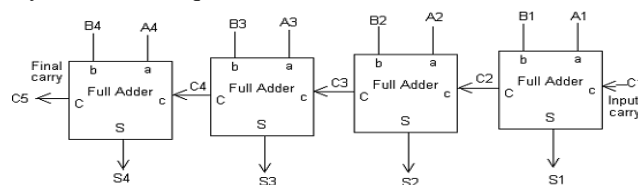

**Carry-Ripple Adder:** An N-bit adder can be constructed by cascading N full adders for N = 4. This is called a carry-ripple adder (or ripple-carry adder). The carry-out of bit i,  $C_i$ , is the carry-in to bit i + 1. This carry is said to have twice the weight of the sum  $S_i$ . The delay of the adder is set by the time for the carries to ripple through the N stages, so the  $t_{Cq} C_{out}$  delay should be minimized.

Every other stage operates on complementary data. The delay inverting the adder inputs or sum outputs is off the critical ripple-carry path.

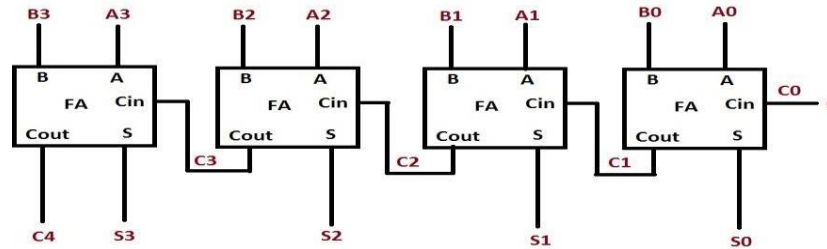

### Magnitude Comparator

A magnitude comparator determines the larger of two binary numbers. To compare two unsigned numbers A and B, compute  $B - A = B + A + 1$ . If there is a carry-out,  $A < B$ ; otherwise,  $A > B$ . A zero detector indicates that the numbers are equal.

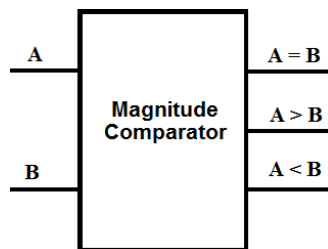

Inputs				Outputs		
A <sub>1</sub>	A <sub>0</sub>	B <sub>1</sub>	B <sub>0</sub>	A>B	A=B	A<B
0	0	0	0	0	1	0
0	0	0	1	0	0	1
0	0	1	0	0	0	1
0	0	1	1	0	0	1
0	1	0	0	1	0	0
0	1	0	1	0	1	0
0	1	1	0	0	0	1
0	1	1	1	0	0	1
1	0	0	0	1	0	0
1	0	0	1	1	0	0
1	0	1	0	0	1	0
1	0	1	1	0	0	1
1	1	0	0	1	0	0
1	1	0	1	1	0	0
1	1	1	0	1	0	0
1	1	1	1	0	1	0

### Shifters:

Shifts can either be performed by a constant or variable amount. Constant shifts are trivial in hardware, requiring only wires. They are also an efficient way to perform multiplication or division by powers of two. A variable shifter takes an N-bit input, A, a shift amount, k, and control signals indicating the shift type and direction. It produces an N-bit output, Y. There are three common types of variable shifts, each of which can be to the left or right: Rotate: Rotate numbers in a circle such that empty spots are filled with bits shifted off the other end

○ Example: 1011 ROR 1 = 1101; 1011 ROL 1 = 0111

Logical shift: Shift the number to the left or right and fills empty spots with zeros.

○ Example: 1011 LSR 1 = 0101; 1011 LSL 1 = 0110

Arithmetic shift: Same as logical shifter, but on right shifts fills the most significant bits with copies of the sign bit (to properly sign, extend two's complement numbers when using right shift by k for division by 2<sup>k</sup>).

○ Example: 1011 ASR 1 = 1101; 1011 ASL 1 = 0110

Conceptually, rotation involves an array of N N-input multiplexers to select each of the outputs from each of the possible input positions. This is called an array shifter. The array shifter requires a decoder to produce the 1-of-N-

hot shift amount. In practice, multiplexers with more than 4–8 inputs have excessive parasitic capacitance, so they are faster to construct from  $\log_2 N$  levels of  $v$ -input multiplexers. This is called a logarithmic shifter.

## VLSI Design Styles

Several design styles can be considered for chip implementation of specified algorithms or logic functions. Each design style has its own merits and shortcomings, and thus a proper choice has to be made by designers in order to provide the specified functionality at low cost and in a timely manner.

**Field Programmable Gate Array (FPGA)** Fully fabricated FPGA chips containing thousands or even more, of logic gates with programmable interconnects, are available to users for their custom hardware programming to realize desired functionality. This design style provides a means for fast prototyping and also for cost-effective chip design, especially for low-volume applications. A typical field programmable gate array (FPGA) chip consists of I/O buffers, an array of configurable logic blocks (CLBs), and programmable interconnect structures. The programming of the interconnects is accomplished by programming of RAM cells whose output terminals are connected to the gates of MOS pass transistors. Thus, the signal routing between the CLBs and the I/O blocks is accomplished by setting the configurable switch matrices accordingly. The general architecture of an FPGA chip from Xilinx . showing the locations of switch matrices used for interconnect routing.

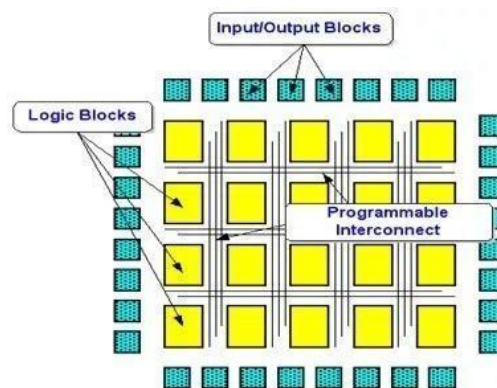

**Gate Array Design** :In terms of fast prototyping capability, the gate array (GA) ranks second after the FPGA with a typical turn-around time of a few days. While user programming is central to the design implementation of the FPGA chip, metal mask design and processing is used for GA. Gate array implementation requires a two-step manufacturing process: The first phase, which is based on generic (standard) masks, results in an array of uncommitted transistors on each GA chip. These uncommitted chips can be stored for later customization, which is completed by defining the metal interconnects between the transistors of the array. Since the patterning of metallic interconnects is done at the end of the chip fabrication process, the turn-around time can still be short, a few days to a few weeks. A corner of a gate array chip which contains bonding pads on its left and bottom edges, diodes for IO protection, nMOS transistors and pMOS transistors for chip output driver circuits adjacent to bonding pads, arrays of nMOS transistors and pMOS transistors, underpass wire segments, and power and ground buses along with contact windows. The availability of these routing channels simplifies the interconnections, even using one metal layer only. Interconnection patterns that perform basic logic gates can be stored in a library, which can then be used to customize rows of uncommitted transistors according to the netlist.

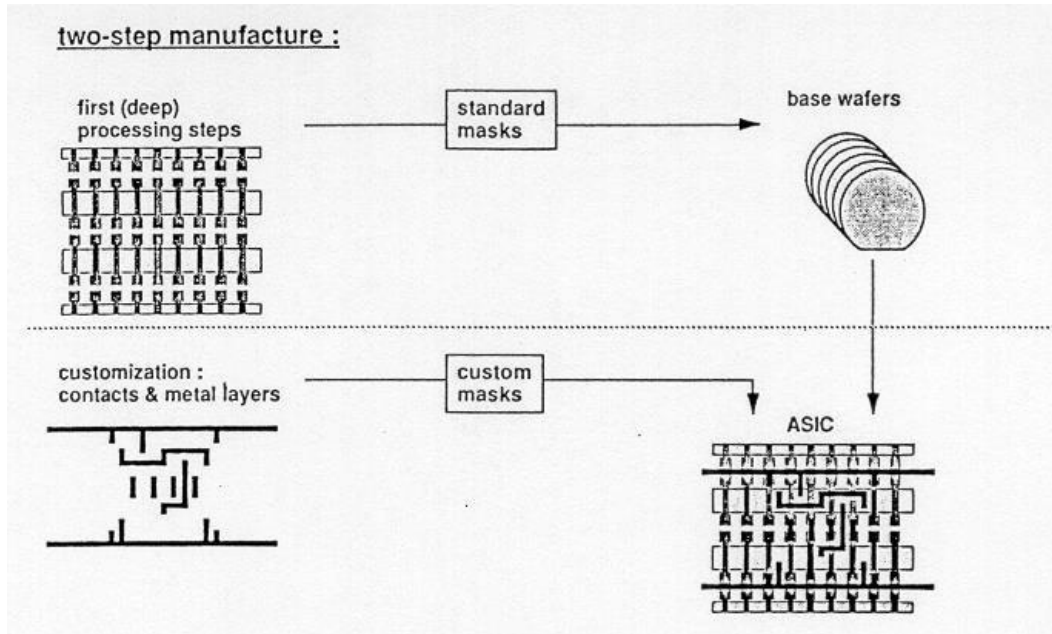

**Standard-Cells Based Design:** The standard-cells based design is one of the most prevalent full custom design styles which require development of a full custom mask set. The standard cell is also called the polycell. In this design style, all of the commonly used logic cells are developed, characterized, and stored in a standard cell library. A typical library may contain a few hundred cells including inverters, NAND gates, NOR gates, complex AOI, OAI gates, D latches, and flip-flops. Each gate type can be implemented in several versions to provide adequate driving capability for different fan-outs. For instance, the inverter gate can have standard size, double size, and quadruple size so that the chip designer can choose the proper size to achieve high circuit speed and layout density. Each cell is characterized according to several different characterization categories, including: Delay time versus load capacitance, Circuit simulation model, Timing simulation model, Fault simulation model, Cell data for place-and-route, Mask data. To enable automated placement of the cells and routing of inter-cell connections, each cell layout is designed with a fixed height, so that a number of cells can be abutted side-by-side to form rows. The power and ground rails typically run parallel to the upper and lower boundaries of the cell, thus, neighboring cells share a common power and ground bus. The input and output pins are located on the upper and lower boundaries of the cell.

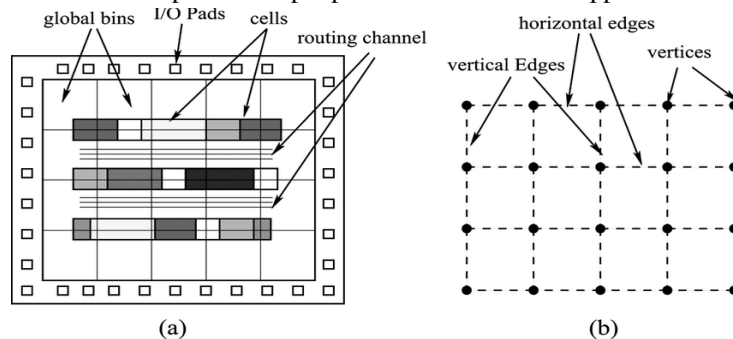

### Full Custom Design

Although the standard-cells based design style is sometimes called full custom design, in a strict sense, it is somewhat less than fully customized since the cells are pre-designed for general use and the same cells are utilized

in many different chip designs. In a truly full-custom design, the entire mask design is done anew without use of any library. However, the development cost of such a design style is becoming prohibitively high. Thus, the concept of design reuse is becoming popular in order to reduce design cycle time and development cost. The most rigorous full custom design can be the design of a memory cell, be it static or dynamic. Since the same layout design is replicated, there would not be any alternative to high density memory chip design. For logic chip design, a good compromise can be achieved by using a combination of different design styles on the same chip, such as standard cells, data-path cells and programmable logic arrays (PLAs). In real full-custom layout in which the geometry, orientation and placement of every transistor is done individually by the designer, design productivity is usually very low - typically a few tens of transistors per day, per designer. In digital CMOS VLSI, full-custom design is rarely used due to the high labor cost. Exceptions to this include the design of high-volume products such as memory chips, high-performance microprocessors and FPGA masters. Figure 14.23 shows the full layout of the Intel 486 microprocessor chip, which is a good example of a hybrid fullcustom design. Here, one can identify four different design styles on one chip: memory banks (RAM cache), data-path units consisting of bit-slice cells, control circuitry mainly consisting of standard cells and PLA blocks.

## UNIT-V CMOS TESTING

### Need for testing

Design of logic integrated circuits in CMOS technology is becoming more and more complex since VLSI is the interest of many electronic IC users and manufacturers. A common problem to be solved by both users and manufacturers is the testing of these ICs.

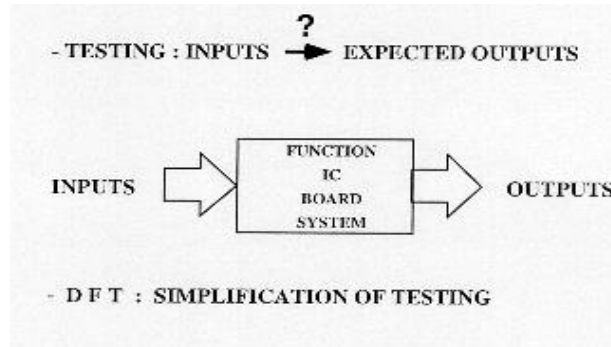

Testing can be expressed by checking if the outputs of a functional system (functional block, Integrated Circuit, Printed Circuit Board or a complete system) correspond to the inputs applied to it. If the test of this functional system is positive, then the system is good for use. If the outputs are different than expected, then the system has a problem: so either the system is rejected (Go/No Go test), or a diagnosis is applied to it, in order to point out and probably eliminate the problem's causes.

Testing is applied to detect faults after several operations : design, manufacturing, packaging and especially during the active life of a system, and thus since failures caused by wear-out can occur at any moment of its usage.

Design for Testability (DFT) is the ability of simplifying the test of any system. DFT could be synthesized by a set of techniques and design guidelines where the goals are :

- minimizing costs of system production
- minimizing system test complexity : test generation and application
- improving quality
- Avoiding problems of timing discordance or block nature incompatibility.

In the production process cycle, a fault can occur at the chip level. If a test strategy is considered at the beginning of the design, then the fault could be detected rapidly, located and eliminated at a very low cost. When the faulty chip is soldered on a printed circuit board, the cost of fault remedy would be multiplied by ten. And this cost factors continues to apply until the system has been assembled and packaged and then sent to users.

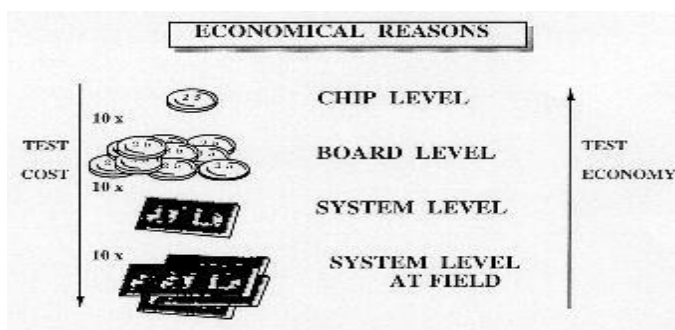

## Manufacturing Tests:

Whereas verification or functionality tests seek to confirm the function of a chip as a whole, manufacturing tests are used to verify that every gate operates as expected. The need to do this arises from a number of manufacturing defects that might occur during either chip fabrication or accelerated life testing (where the chip is stressed by over-voltage and over-temperature operation).

Typical defects include the following:

- Layer-to-layer shorts (e.g., metal-to-metal)
- Discontinuous wires (e.g., metal thins when crossing vertical topology jumps)
- Missing or damaged vias
- Shorts through the thin gate oxide to the substrate or well

These in turn lead to particular circuit maladies, including the following

- Nodes shorted to power or ground
- Nodes shorted to each other
- Inputs floating/outputs disconnected

Tests are required to verify that each gate and register is operational and has not been compromised by a manufacturing defect. Tests can be carried out at the wafer level to cull out bad dies, or can be left until the parts are packaged. This decision would normally be determined by the yield and package cost. If the yield is high and the package cost low (i.e., a plastic package), then the part can be tested only once after packaging. However, if the wafer yield was lower and the package cost high (i.e., an expensive ceramic package), it is more economical to first screen bad dice at the wafer level. The length of the tests at the wafer level can be shortened to reduce test time based on experience with the test sequence.

Apart from the verification of internal gates, I/O integrity is also tested, with the following tests being completed:

- I/O levels (i.e., checking noise margin for TTL, ECL, or CMOS I/O pads)
- Speed test

With the use of on-chip test structures described here, full-speed wafer testing can be completed with a minimum of connected pins. This can be important in reducing the cost of the wafer test fixture.

In general, manufacturing test generation assumes the function of the circuit/chip is correct. It requires ways of exercising all gate inputs and monitoring all gate outputs.

***Test Principles:*** The purpose of manufacturing test is to screen out most of the defective parts before they are shipped to customers. Typical commercial products target a defect rate of 350–1000 defects per million (DPM) chips shipped.

### ***Fault Models***

To deal with the existence of good and bad parts, it is necessary to propose a fault model; i.e., a model for how faults occur and their impact on circuits. The most popular model is called the Stuck-At model. The Short Circuit/ Open Circuit model can be a closer fit to reality, but is harder to incorporate into logic simulation tools.

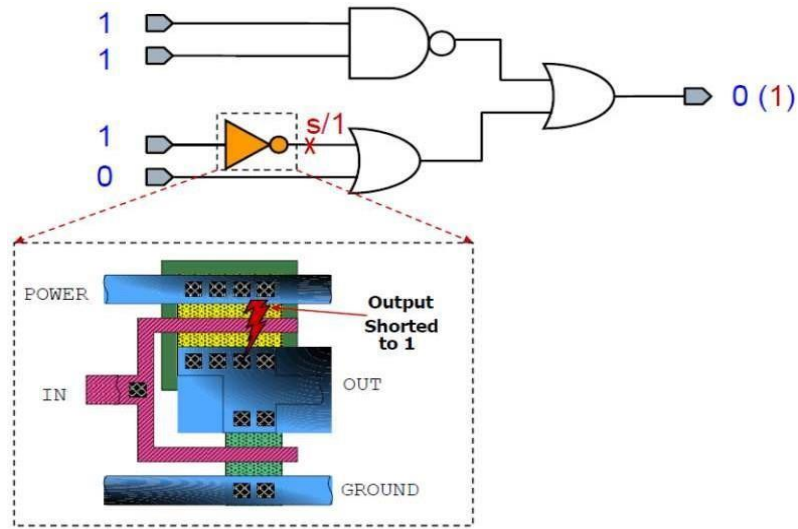

Stuck-At Faults In the Stuck-At model, a faulty gate input is modeled as a stuck at zero (Stuck-At-0, S-A-0) or stuck at one (Stuck-At-1, S-A-1). This model dates from board-level designs, where it was determined to be adequate for modeling faults. Figure illustrates how an S-A-0 or S-A-1 fault might occur. These faults most frequently occur due to gate oxide shorts (the nMOS gate to GND or the pMOS gate to VDD) or metal-to-metal shorts.

Short-Circuit and Open-Circuit Faults Other models include stuck-open or shorted models. Two bridging or shorted faults are shown in Figure. The short S1 results in an S-A-0 fault at input A, while short S2 modifies the function of the gate.

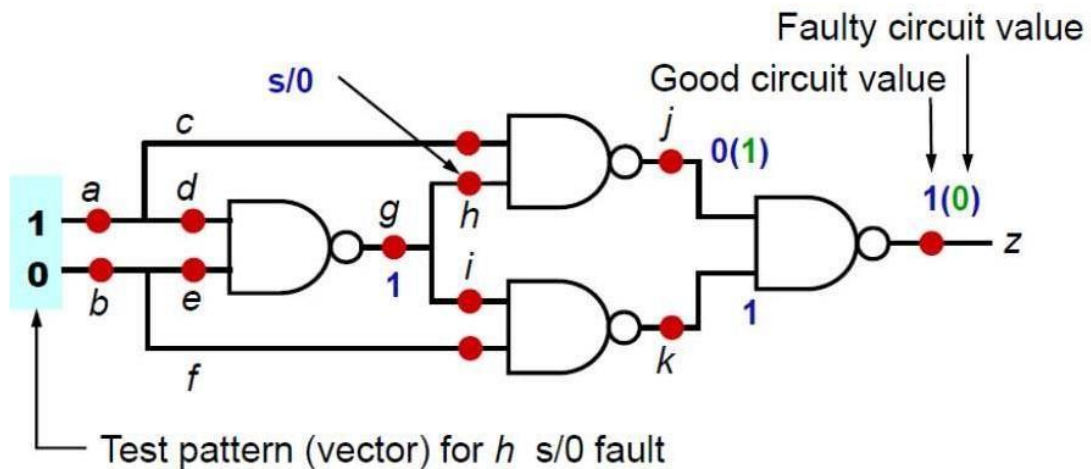

It is evident that to ensure the most accurate modeling, faults should be modeled at the transistor level because it is only at this level that the complete circuit structure is known. For instance, in the case of a simple NAND gate, the intermediate node between the series nMOS transistors is hidden by the schematic. This implies that test generation should ideally take account of possible shorts and open circuits at the switch level. Expediency dictates that most

existing systems rely on Boolean logic representations of circuits and stuck-at fault modeling.

### ***Observability***

The observability of a particular circuit node is the degree to which you can observe that node at the outputs of an integrated circuit (i.e., the pins). This metric is relevant when you want to measure the output of a gate within a larger circuit to check that it operates correctly. Given the limited number of nodes that can be directly observed, it is the aim of good chip designers to have easily observed gate outputs. Adoption of some basic design for test techniques can aid tremendously in this respect. Ideally, you should be able to observe directly or with moderate indirection (i.e., you may have to wait a few cycles) every gate output within an integrated circuit. While at one time this aim was hindered by the expense of extra test circuitry and a lack of design methodology, current processes and design practices allow you to approach this ideal.

### ***Controllability***

The controllability of an internal circuit node within a chip is a measure of the ease of setting the node to a 1 or 0 state. This metric is of importance when assessing the degree of difficulty of testing a particular signal within a circuit. An easily controllable node would be directly settable via an input pad. A node with little controllability, such as the most significant bit of a counter, might require many hundreds or thousands of cycles to get it to the right state. Often, you will find it impossible to generate a test sequence to set a number of poorly controllable nodes into the right state. It should be the aim of good chip designers to make all nodes easily controllable. In common with observability, the adoption of some simple design for test techniques can aid in this respect tremendously. Making all flip-flops resettable via a global reset signal is one step toward good controllability.

### ***Fault Coverage***

A measure of goodness of a set of test vectors is the amount of fault coverage it achieves. That is, for the vectors applied, what percentages of the chip's internal nodes were checked? Conceptually, the way in which the fault coverage is calculated is as follows. Each circuit node is taken in sequence and held to 0 (S-A-0), and the circuit is simulated with the test vectors comparing the chip outputs with a known good machine—a circuit with no nodes artificially set to 0 (or 1). When a discrepancy is detected between the faulty machine and the good machine, the fault is marked as detected and the simulation is stopped. This is repeated for setting the node to 1 (S-A-1). In turn, every node is stuck (artificially) at 1 and 0 sequentially. The fault coverage of a set of test vectors is the percentage of the total nodes that can be detected as faulty when the vectors are applied. To achieve world-class

quality levels, circuits are required to have in excess of 98.5% fault coverage. The Verification Methodology Manual is the bible for fault coverage techniques.

## How to Test Chips?

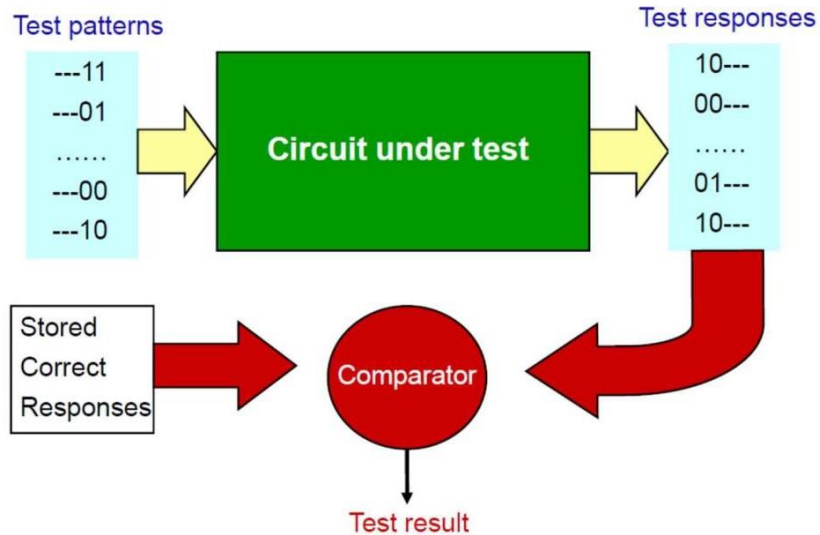

**IDDQ TESTING:** It is a simple method to identify defects on IC on the steady state power supply current. It is also a method for testing CMOS integrated circuits for the presence of manufacturing faults. It relies on measuring the supply current (I<sub>dd</sub>) in the quiescent state (when the circuit is not switching and inputs are held at static values). The current consumed in the state is commonly called I<sub>ddq</sub> for I<sub>dd</sub> (quiescent) and hence the name. I<sub>ddq</sub> testing uses the principle that in a correctly operating quiescent CMOS digital circuit, there is no static current path between the power supply and ground, except for a small amount of leakage. Many common semiconductor manufacturing faults will cause the current to increase by orders of magnitude, which can be easily detected. This has the advantage of checking the chip for many possible faults with one measurement. Another advantage is that it may catch faults that are not found by conventional stuck-at fault test vectors. I<sub>ddq</sub> testing is somewhat more complex than just measuring the supply current. If a line is shorted to V<sub>dd</sub>, for example, it will still draw no extra current if the gate driving the signal is attempting to set it to '1'. However, a different vector set that attempts to set the signal to 0 will show a large increase in quiescent current, signaling a bad part. Typical I<sub>ddq</sub> test vector sets may have 20 or so vectors. Note that I<sub>ddq</sub> test vectors require only controllability, and not observability. This is because the observability is through the shared power supply connection. I<sub>ddq</sub> testing has many advantages:

- It is a simple and direct test that can identify physical defects.
- The area and design time overhead are very low.
- Test generation is fast.

- Test application time is fast since the vector sets are small.
- It catches some defects that other tests, particularly stuck-at logic tests, do not.

Drawback: Compared to scan testing, Iddq testing is time consuming, and then more expensive, since is achieved by current measurements that take much more time than reading digital pins in mass production.

### ***AUTOMATIC TEST PATTERN GENERATION (ATPG)***

Historically, in the IC industry, logic and circuit designers implemented the functions at the RTL or schematic level, mask designers completed the layout, and test engineers wrote the tests. In many ways, the test engineers were the Sherlock Holmes of the industry, reverse engineering circuits and devising tests that would test the circuits in an adequate manner. For the longest time, test engineers implored circuit designers to include extra circuitry to ease the burden of test generation. Happily, as processes have increased in density and chips have increased in complexity, the inclusion of test circuitry has become less of an overhead for both the designer and the manager worried about the cost of the die. In addition, as tools have improved, more of the burden for generating tests has fallen on the designer. To deal with this burden, Automatic Test Pattern Generation (ATPG) methods have been invented. The use of some form of ATPG is standard for most digital designs.

It is the process of generating test patterns for a given fault model. If we go by exhaustive testing, in the worst case, we may require  $2^n$  (where  $n$  stands for no. of primary inputs) assignments to be applied for finding test vector for a single stuck-at fault. It is impossible for us to manually use exhaustive testing or path sensitization method to generate a test pattern for chips consisting of millions of transistors. Hence, we need an automated process, a.k.a. Automatic Test Pattern Generation (ATPG).

A cycle of ATPG can generally be divided into two distinct phases: 1) creation of the test; and 2) application of the test. During the creation of the test, appropriate models for the device circuit are developed at gate or transistor level in such a way that the output responses of a faulty device for a given set of inputs will differ from those of a good device. This generation of test is basically a mathematical process that can be done in three ways:

1) by manual methods; 2) by algorithmic methods (with or without heuristics); and 3) by pseudo-random methods. The software used for complex ATPG applications are quite expensive, but the process of generating a test needs to be done only once at the end of the design process.

When creating a test, the goal should be to make it as efficient in memory space and time requirements as much as possible. As such, the ATPG process must generate the

minimum or near minimum set of vectors needed to detect all the important faults of a device. The main considerations for test creation are: 1) the time needed to construct the minimal test set; 2) the size of the pattern generator, or hardware/software system needed to properly stimulate the devices under test; 3) the size of the testing process itself; 4) the time needed to load the test patterns; and 5) the external equipment required (if any).

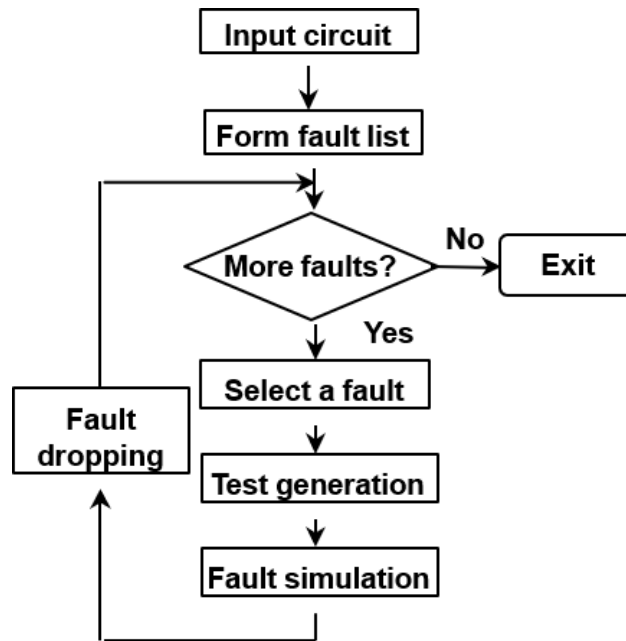

### ***DESIGN STRATEGIES FOR TEST,***

Design for Testability The keys to designing circuits that are testable are controllability and observability. Restated, controllability is the ability to set (to 1) and reset (to 0) every node internal to the circuit. Observability is the ability to observe, either directly or indirectly, the state of any node in the circuit. Good observability and controllability reduce the cost of manufacturing testing because they allow high fault coverage with relatively few test vectors. Moreover, they can be essential to silicon debug because physically probing internal signals has become so difficult.

We will first cover three main approaches to what is commonly called Design for Testability (DFT). These may be categorized as follows:

Ad hoc testing

Scan-based approaches

Built-in self-test (BIST)

#### ***Ad Hoc Testing***

Ad hoc test techniques, as their name suggests, are collections of ideas aimed at reducing the combinational explosion of testing. They are summarized here for historical reasons. They are only useful for small designs where scan, ATPG, and BIST are not available. A complete scan-based testing methodology is recommended for all digital circuits. Having said that, the following are common techniques for ad hoc testing:

- Partitioning large sequential circuits
- Adding test points
- Adding multiplexers
- Providing for easy
- state reset

A technique classified in this category is the use of the bus in a bus-oriented system for test purposes. Each register has been made loadable from the bus and capable of being driven onto the bus. Here, the internal logic values that exist on a data bus are enabled onto the bus for testing purposes. Frequently, multiplexers can be used to provide alternative signal paths during testing. In CMOS, transmission gate multiplexers provide low area and delay overhead. Any design should always have a method of resetting the internal state of the chip within a

single cycle or at most a few cycles. Apart from making testing easier, this also makes simulation faster as a few cycles are required to initialize the chip.

In general, ad hoc testing techniques represent a bag of tricks developed over the years by designers to avoid the overhead of a systematic approach to testing, as will be described in the next section. While these general approaches are still quite valid, process densities and chip complexities necessitate a structured approach to testing.

### ***SCAN BASED TECHNIQUE***

The scan-design strategy for testing has evolved to provide observability and controllability at each register. In designs with scan, the registers operate in one of two modes. In normal mode, they behave as expected. In scan mode, they are connected to form a giant shift register called a scan chain spanning the whole chip. By applying N clock pulses in scan mode, all N bits of state in the system can be shifted out and new N bits of state can be shifted in. Therefore, scan mode gives easy observability and controllability of every register in the system.

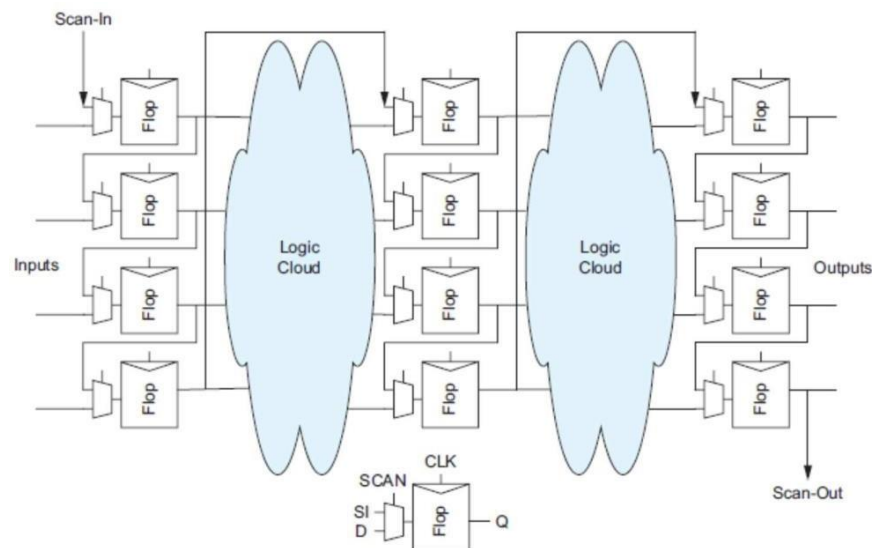

Modern scan is based on the use of scan registers, as shown in Figure. The scan register is a D flip-flop preceded by a multiplexer. When the SCAN signal is deasserted, the register behaves as a conventional register, storing data on the D input. When SCAN is asserted, the data is loaded from the SI pin, which is connected in shift register fashion to the previous register Q output in the scan chain. For the circuit to load the scan chain, SCAN is asserted and CLK is pulsed eight times to load the first two ranks of 4-bit registers with data. SCAN is

deasserted and CLK is asserted for one cycle to operate the circuit normally with predefined inputs. SCAN is then reasserted and CLK asserted eight times to read the stored data out. At the same time, the new register contents can be shifted in for the next test. Testing proceeds in this manner of serially clocking the data through the scan register to the right point in the circuit, running a single system clock cycle and serially clocking the data out for observation. In this scheme, every input to the combinational block can be controlled and every output can be observed. In addition, running a random pattern of 1s and 0s through the scan chain can test the chain itself.

Test generation for this type of test architecture can be highly automated. ATPG techniques can be used for the combinational blocks and, as mentioned, the scan chain is easily tested. The prime disadvantage is the area and delay impact of the extra multiplexer in the scan register. Designers (and managers alike) are in widespread agreement that this cost is more than offset by the savings in debug time and production test cost.

### **Scan Design Techniques**

The set of design for testability guidelines presented above is a set of ad hoc methods to design random logic in respect with testability requirements. The scan design techniques are a set of structured approaches to design (for testability) the sequential circuits.

The major difficulty in testing sequential circuits is determining the internal state of the circuit. Scan design techniques are directed at improving the controllability and observability of the internal states of a sequential circuit. By this the problem of testing a sequential circuit is reduced to that of testing a combinational circuit, since the internal states of the circuit are under control.

#### **8.8.1 Scan Path**

The goal of the scan path technique is to reconfigure a sequential circuit, for the purpose of testing, into a combinational circuit. Since a sequential circuit is based on a combinational circuit and some storage elements, the technique of scan path consists in connecting together all the storage elements to form a long serial shift register. Thus the internal state of the circuit can be observed and controlled by shifting (scanning) out the contents of the storage elements. The shift register is then called a scan path.

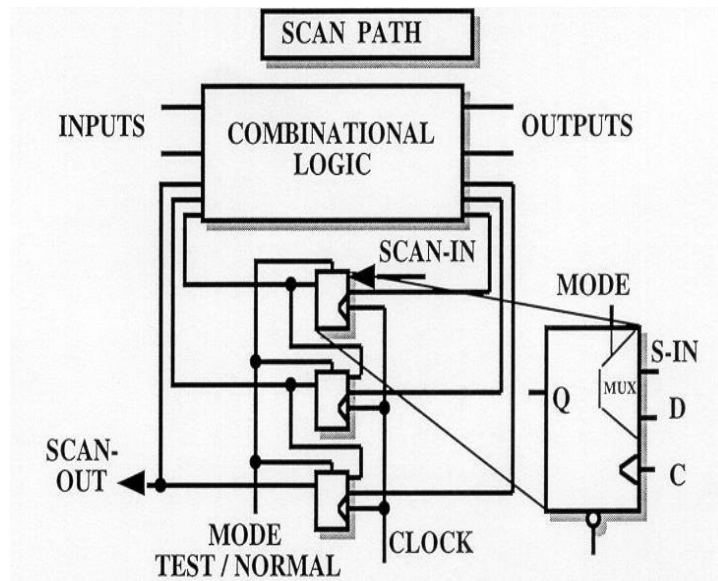

The storage elements can either be D, J-K, or R-S types of flip-flops, but simple latches cannot be used in scan path. However, the structure of storage elements is slightly different than classical ones. Generally the selection of the input source is achieved using a multiplexer on the data input controlled by an external mode signal. This multiplexer is integrated into the D-flip-flop, in our case; the D-flip-flop is then called MD-flip-flop (multiplexed-flip-flop).

The sequential circuit containing a scan path has two modes of operation : a normal mode and a test mode which configure the storage elements in the scan path.

In the normal mode, the storage elements are connected to the combinational circuit, in the loops of the global sequential circuit, which is considered then as a finite state machine.

In the test mode, the loops are broken and the storage elements are connected together as a serial shift register (scan path), receiving the same clock signal. The input of the scan path is called scan-in and the output scan-out. Several scan paths can be implemented in one same complex circuit if it is necessary, though having several scan-in inputs and scan-out outputs.

A large sequential circuit can be partitioned into sub-circuits, containing combinational sub-circuits, associated with one scan path each. Efficiency of the test pattern generation for a combinational sub-circuit is greatly improved by partitioning, since its depth is reduced.

Before applying test patterns, the shift register itself has to be verified by shifting in all ones i.e. 111...11, or zeros i.e. 000...00, and comparing.

The method of testing a circuit with the scan path is as follows:

1. Set test mode signal, flip-flops accept data from input scan-in

2. Verify the scan path by shifting in and out test data
3. Set the shift register to an initial state
4. Apply a test pattern to the primary inputs of the circuit
5. Set normal mode, the circuit settles and can monitor the primary outputs of the circuit
6. Activate the circuit clock for one cycle
7. Return to test mode
8. Scan out the contents of the registers, simultaneously scan in the next pattern

***SELF-TEST APPROACHES: BUILT-IN SELF-TEST (BIST)***

Self-test and built-in test techniques, as their names suggest, rely on augmenting circuits to allow them to perform operations upon themselves that prove correct operation. These techniques add area to the chip for the test logic, but reduce the test time required and thus can lower the overall system cost. [Stroud02] offers extensive coverage of the subject from the implementer’s perspective.

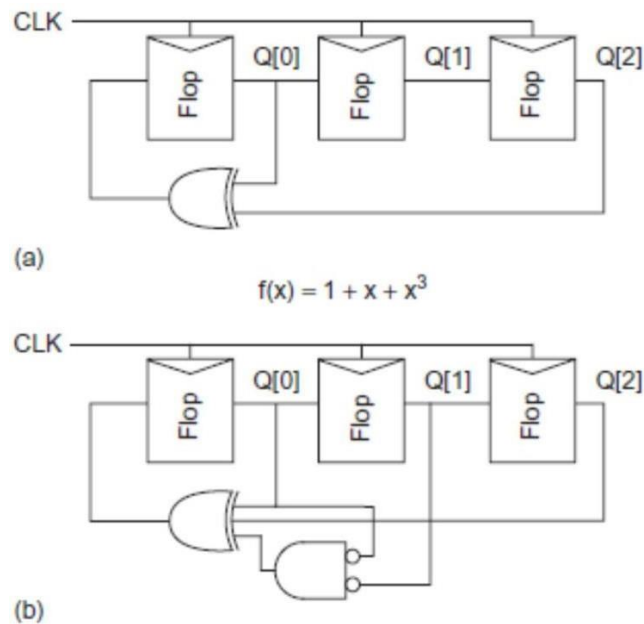

One method of testing a module is to use signature analysis or cyclic redundancy checking. This involves using a pseudo-random sequence generator (PRSG) to produce the input signals for a section of combinational circuitry and a signature analyzer to observe the output signals. A PRSG of length  $n$  is constructed from a linear feedback shift register (LFSR), which in turn is made of  $n$  flip-flops connected in a serial fashion, as shown in Figure (a). The XOR of particular outputs are fed back to the input of the LFSR. An  $n$ -bit LFSR will cycle through  $2^n - 1$  states before repeating the sequence. LFSRs are discussed further in Section They are described by a characteristic polynomial indicating which bits are fed back. A complete feedback shift register (CFSR), shown in Figure (b), includes the zero state that may be required in some test situations. An  $n$ -bit LFSR is converted to an  $n$ -bit CFSR by adding an  $n - 1$  input NOR gate connected to all but the last bit. When in state  $0 \dots 01$ , the next state is  $0 \dots 00$ . When in state  $0 \dots 00$ , the next state is  $10 \dots 0$ . Otherwise, the sequence is the same. Alternatively, the bottom  $n$  bits of an  $n + 1$ -bit LFSR can be used to cycle through the all zeros state without the delay of the NOR gate.

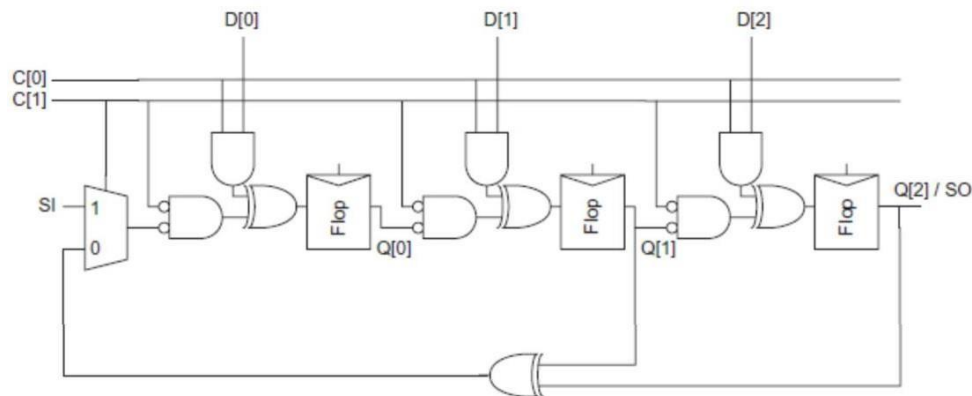

(a)

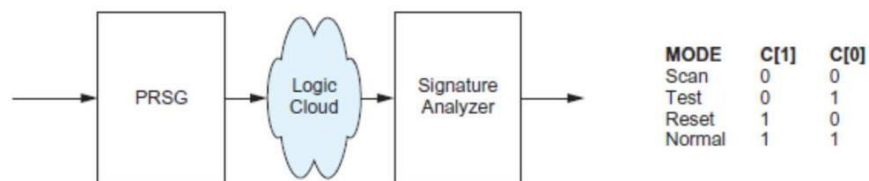

(b)

A signature analyzer receives successive outputs of a combinational logic block and produces a syndrome that is a function of these outputs. The syndrome is reset to 0, and then XORed with the output on each cycle. The syndrome is swizzled each cycle so that a fault in one bit is unlikely to cancel itself out. At the end of a test sequence, the LFSR contains the syndrome that is a function of all previous outputs. This can be compared with the correct

syndrome (derived by running a test program on the good logic) to determine whether the circuit is good or bad. If the syndrome contains enough bits, it is improbable that a defective circuit will produce the correct syndrome.

The combination of signature analysis and the scan technique creates a structure known as BIST—for Built-In Self-Test or BILBO—for Built-In Logic Block Observation. The 3-bit BIST register shown in Figure is a scannable, resettable register that also can serve as a pattern generator and signature analyzer. C[1:0] specifies the mode of operation. In the reset mode (10), all the flip-flops are synchronously initialized to 0. In normal mode (11), the flip-flops behave normally with their D input and Q output. In scan mode (00), the flip-flops are configured as a 3-bit shift register between SI and SO. Note that there is an inversion between each stage. In test mode (01), the register behaves as a pseudo-random sequence generator or signature analyzer. If all the D inputs are held low, the Q outputs loop through a pseudo-random bit sequence, which can serve as the input to the combinational logic. If the D inputs are taken from the combinational logic output, they are swizzled with the existing state to produce the syndrome. In summary, BIST is performed by first resetting the syndrome in the output register. Then both registers are placed in the test mode to produce the pseudo-random inputs and calculate the syndrome. Finally, the syndrome is shifted out through the scan chain.

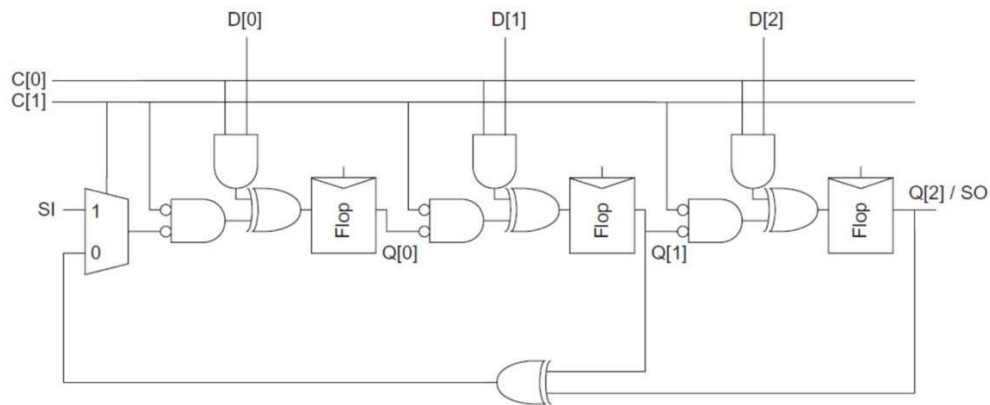

(a)

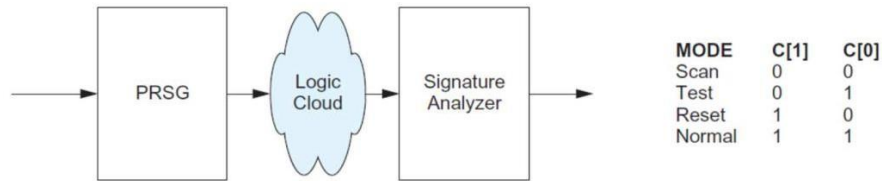

(b)

Various companies have commercial design aid packages that automatically replace ordinary registers with scannable BIST registers, check the fault coverage, and generate scripts for production testing. As an example, on a WLAN modem chip comprising roughly 1 million gates, a full at-speed test takes under a second with BIST. This comes with roughly a 7.3% overhead in the core area (but actually zero because the design was pad limited) and a 99.7% fault coverage level. The WLAN modem parts designed in this way were fully tested in less than ten minutes on receipt of first silicon. This kind of test method is incredibly valuable for productivity in manufacturing test generation.

### ***Memory BIST***

On many chips, memories account for the majority of the transistors. A robust testing methodology must be applied to provide reliable parts. In a typical MBIST scheme, multiplexers are placed on the address, data, and control inputs for the memory to allow direct access during test. During testing, a state machine uses these multiplexers to directly write a checkerboard pattern of alternating 1s and 0s. The data is read back, checked, then the inverse pattern is also applied and checked. ROM testing is even simpler: The contents are read out to a signature analyzer to produce a syndrome.

### **Boundary Scan Test (BST)**

Boundary Scan Test (BST) is a technique involving scan path and self-testing techniques to resolve the problem of testing boards carrying VLSI integrated circuits and/or surface mounted devices (SMD).

Printed circuit boards (PCB) are becoming very dense and complex, especially with SMD circuits, that most test equipment cannot guarantee a good fault coverage.

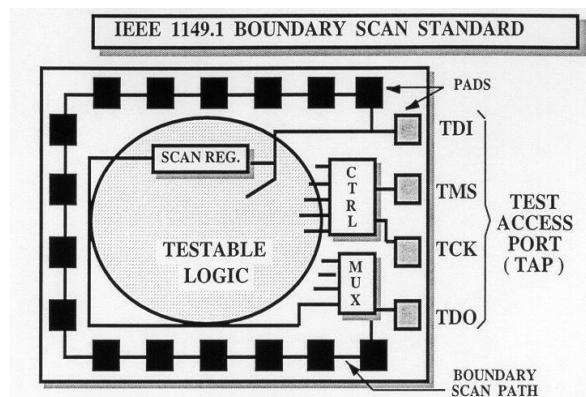

BST consists in placing a scan path (shift register) adjacent to each component pin and to interconnect the cells in order to form a chain around the border of the circuit. The BST circuits contained on one board are then connected together to form a single path through the board.

The boundary scan path is provided with serial input and output pads and appropriate

clock pads which make it possible to :

- Test the interconnections between the various chip
- Deliver test data to the chips on board for self-testing
- Test the chips themselves with internal self-test

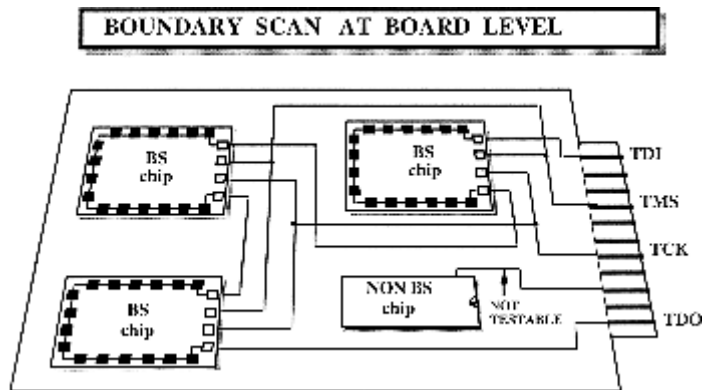

The advantages of Boundary scan techniques are as follows :

- No need for complex testers in PCB testing
- Test engineers work is simplified and more efficient
- Time to spend on test pattern generation and application is reduced
- Fault coverage is greatly increased.

BS Techniques are grouped by the IEEE Standard Organization in a "standard test access port and boundary scan architecture", namely IEEE P1149.1-1990. The Joint Test Action Group (JTAG), formed basically in 1986 at Philips, is an international committee composed of IC manufacturers who have set the technical development of the IEEE P1149 standard and promoted its use by all sectors of electronics industry.

The IEEE 1149 is a family of overall testability bus standards, defined by the Joint Test Action Group (JTAG), formed basically in 1986 at Philips. JTAG is an international committee composed of European and American IC manufacturers. The "standard Test Access Port and Boundary Scan architecture", namely IEEE P1149.1 accepted by the IEEE standard committee in February 1990, is the first one of this family. Several other ongoing standards are developed and suggested as drafts to the technical committee of the IEEE 1149 standard in order to promote their use by all sectors of electronics industry.

\*\*\*\*\*